

Apolon



## OBLIKOVANJE OBITELJSKIH KUĆA 10.XII,2013.

tradicionalizam - modernizam  
historicizam - futurizam

moderna  
“organic architecture”  
neoplasticizam  
funkcionalizam  
internacionalni stil  
konstruktivizam  
postmoderna  
neo-klasicizam  
neo-vernakularna  
minimalizam  
retromoderna  
dekostruktivizam  
high-tech

“stil 2013” = ?

Dioniz



Friedrich

# NIETZSCHE

Rođenje tragedije

“U Rođenju tragedije Nietzsche tvrdi da postoje dvije glavne vrste umjetnosti, apolonijska i dionizijska. Apolon je bio grčki bog uzvišenog sanjanja, samo-kontrole, liječenja, općeg razuma i udaljenosti. Njegova dijametralna suprotnost, Dioniz, je bio bog vina, ekcesa, divljine, gnjeva, emocija i strasti.”



1844. – 1900.



GEORGES SEURAT

Sunday Afternoon on the Island of La Grande Jatte



1830.



1970.



**Puvis de Chavannes, 1879.**



**Picasso, 1907.**



Apolinijevska slika

**magritte**



Dionizijevski prizor

**WOODSTOCK**

**PAROLE  
SLOGANI  
stavovi**

**MEDEN AGAN**

(ničeg previše)

*Appolo temple – Delfi*

**"less is more"**

*Mies van der Rohe*

**"Sacer Simplicitas" = minimalism**

**"prisme pour"** (je ljepota)

5 točaka nove arhitekture

*Le Corbusier '20te'30te*

**"ornament and crime"**

(= ornament je zločin)

*A. Loos*

**"form follows function"**

**EK-STASIS**

(svega u izobilju)

**"exuberance is beauty"**

**"the destruction of the box"**

*F.L.Wright*

**"less is bore"**

**"complexity & contradiction"**

**"Learning from Las Vegas"**

(=učeci iz kaosa)

*R. Venturi*

**deconstruction="no rule architecture"**

**"raumplan"** (je lijep)

*A.Loos*

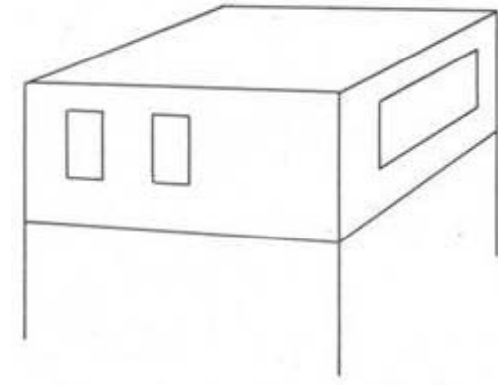
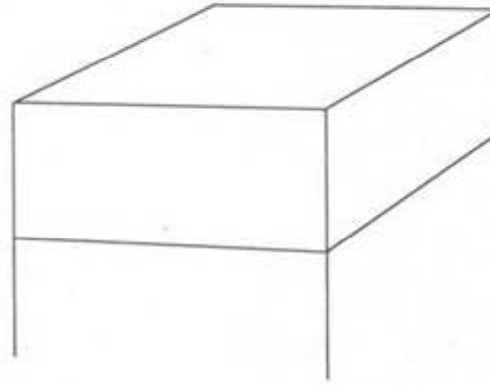

**"the destruction of the box"**

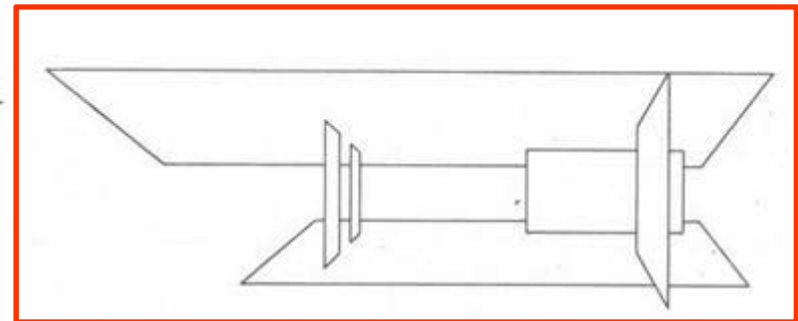
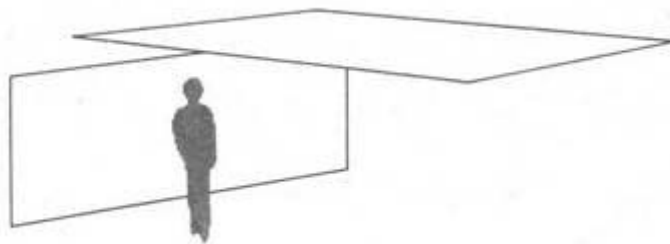
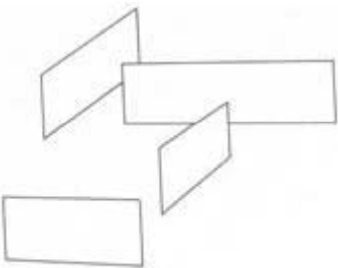
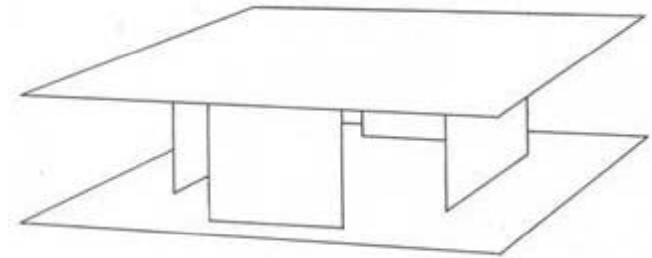
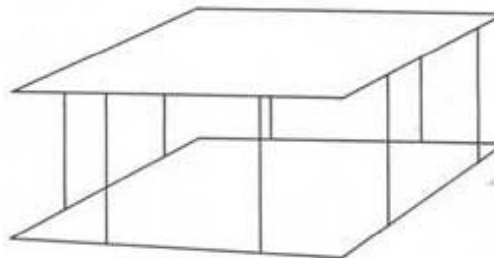
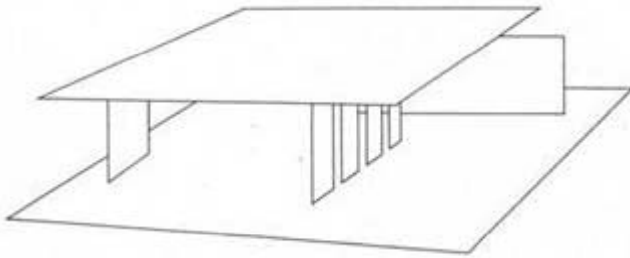

\*

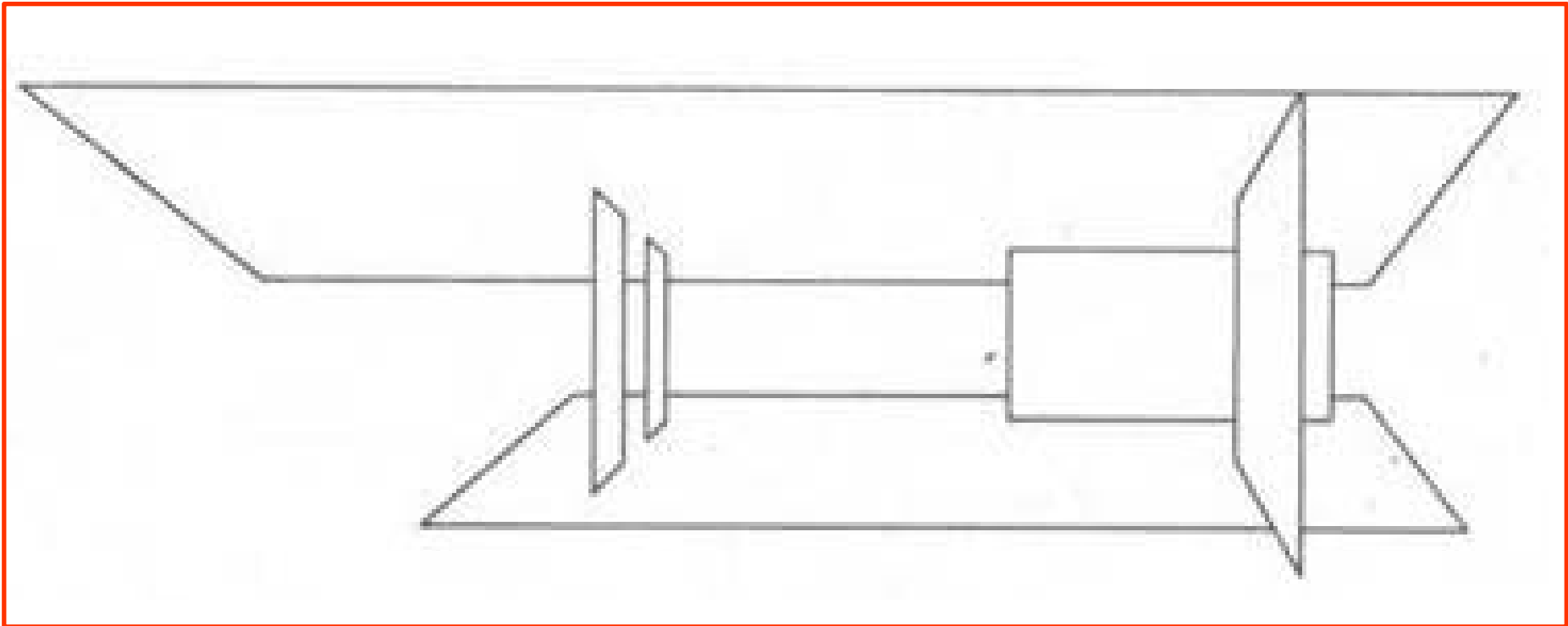

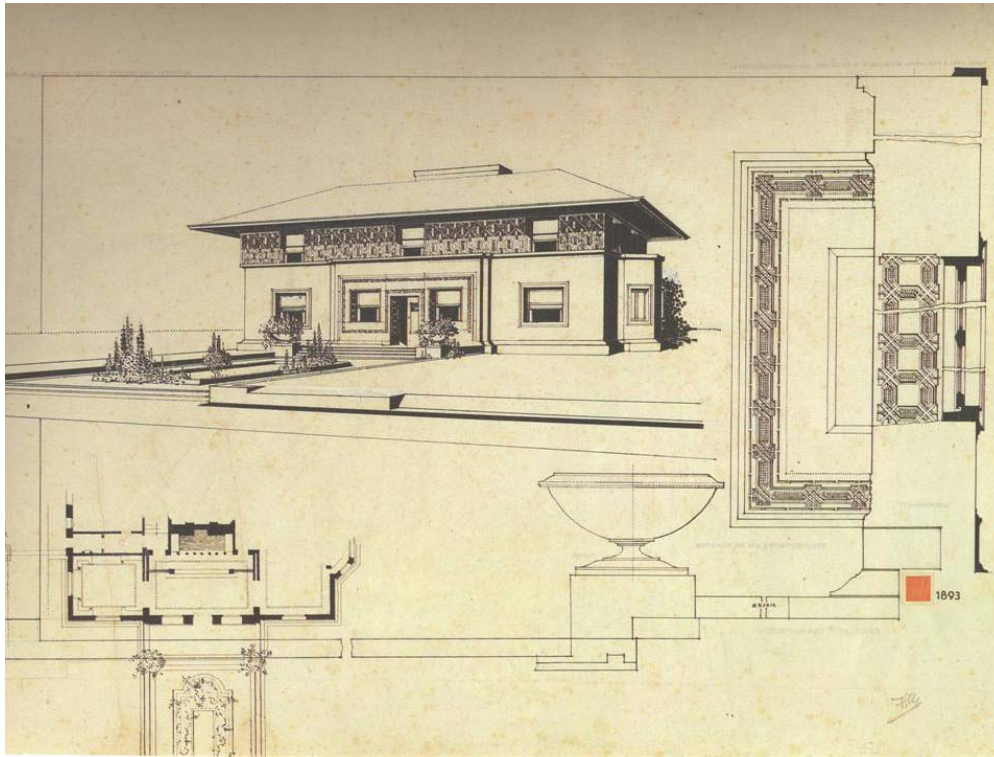

Frank Lloyd Wright: Winslow House, Chicago, 1893.

Froebel-igračke

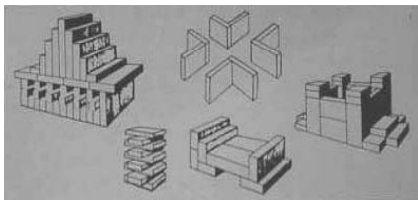

japanska kuća

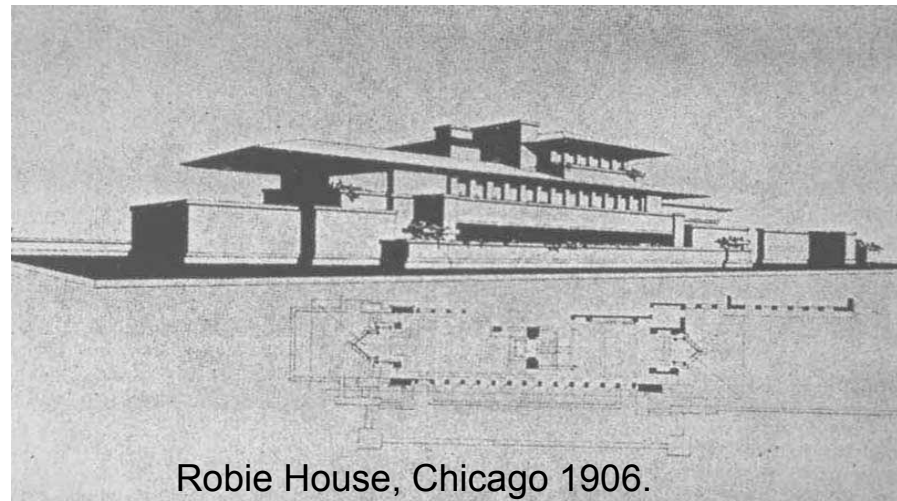

Robie House, Chicago 1906.

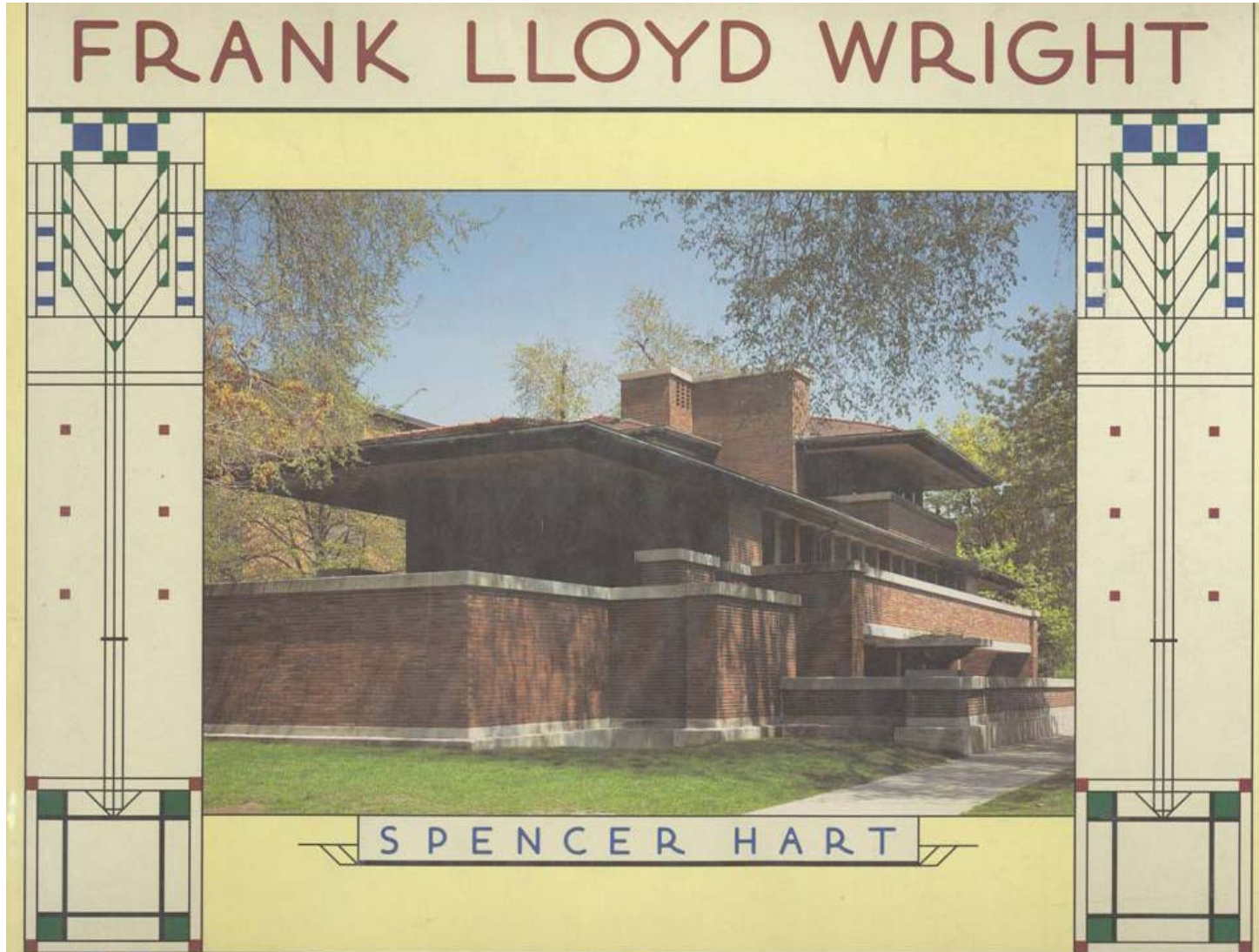
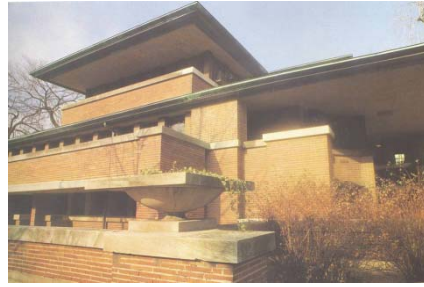

Frank Lloyd Wright: Robie House, Chicago, 1906.

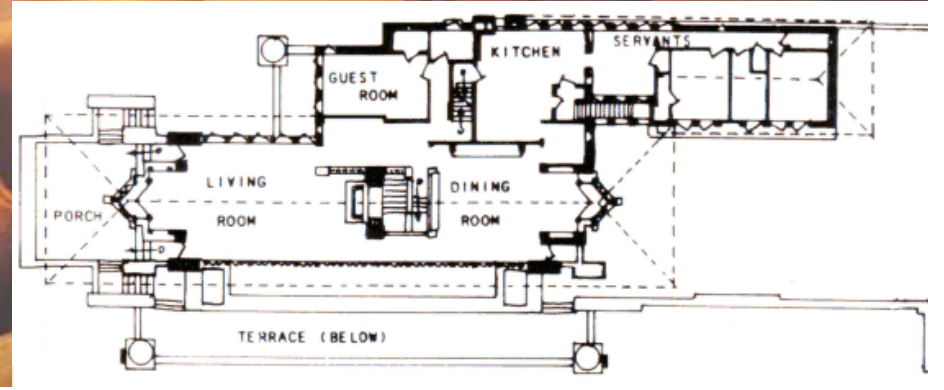
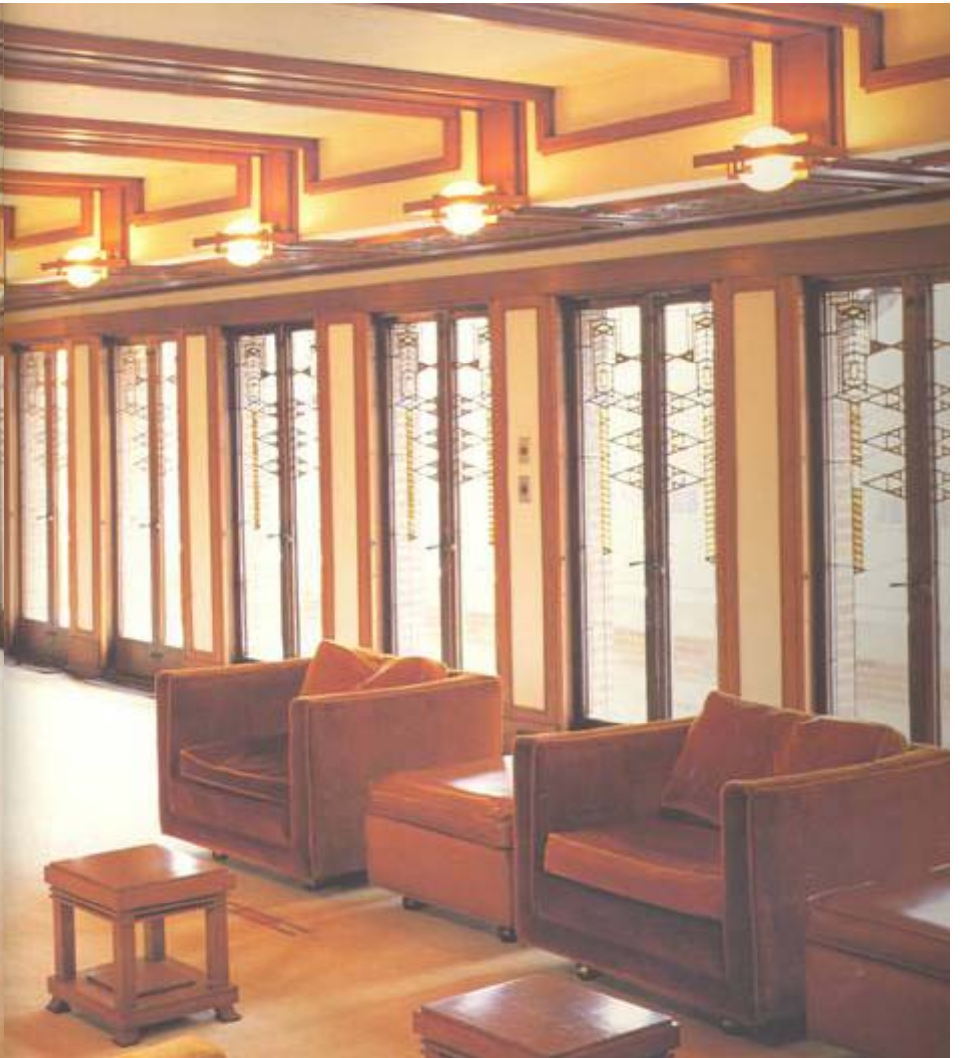
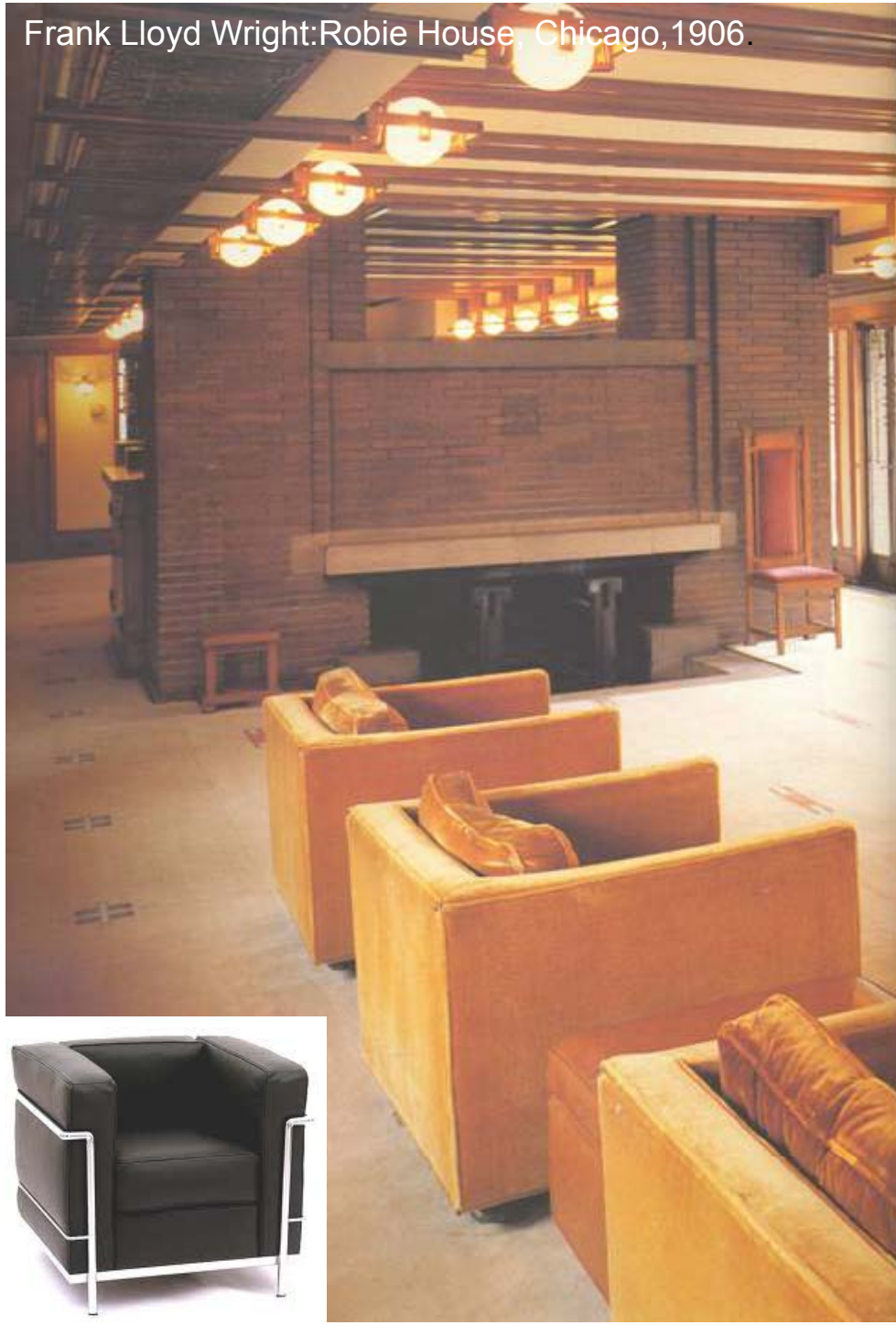

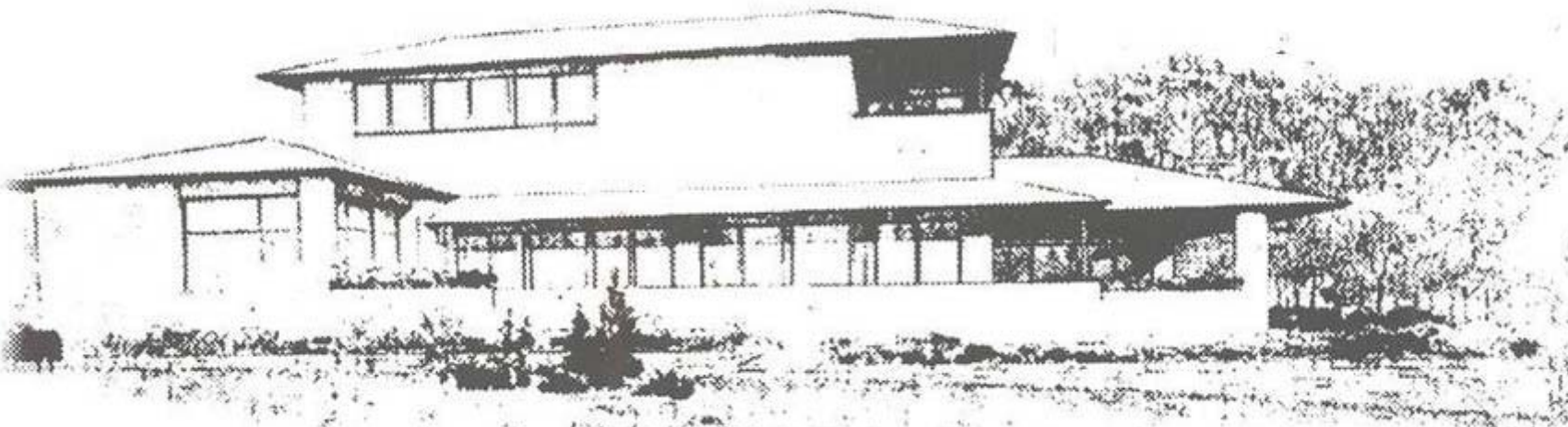
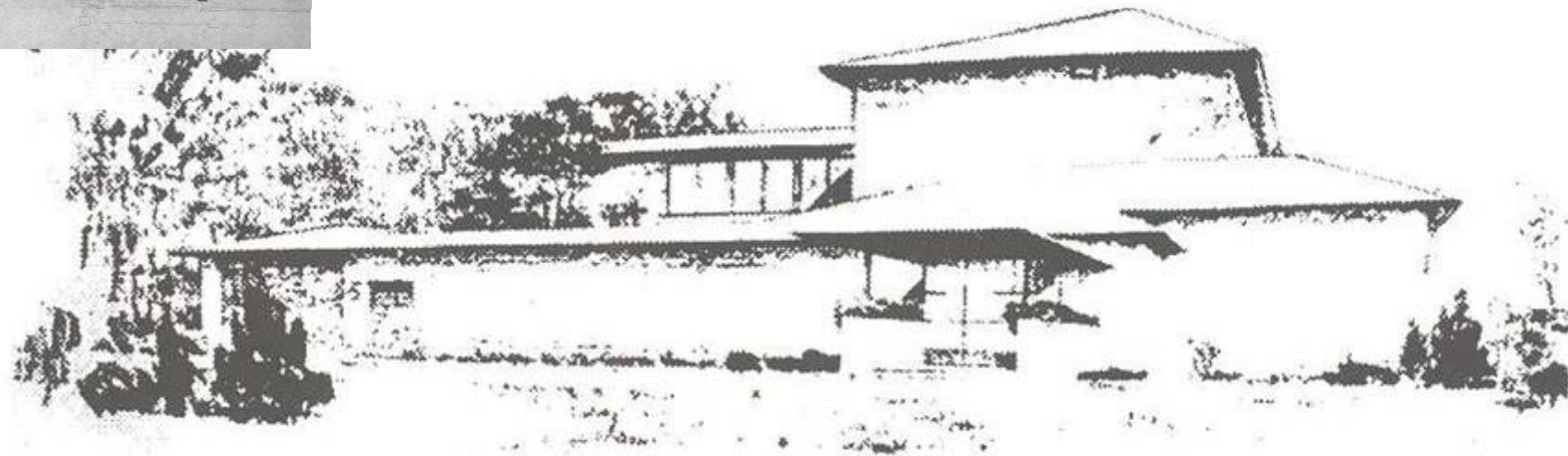
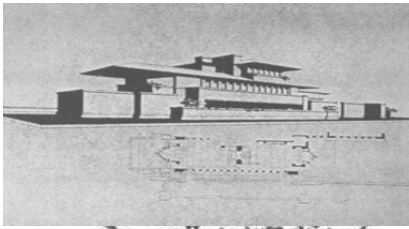

**KAUZLARIĆ & GOMBOŠ – VILA SHELL, Prekrižje, Zagreb, 1930te**

# FRANK LLOYD WRIGHT

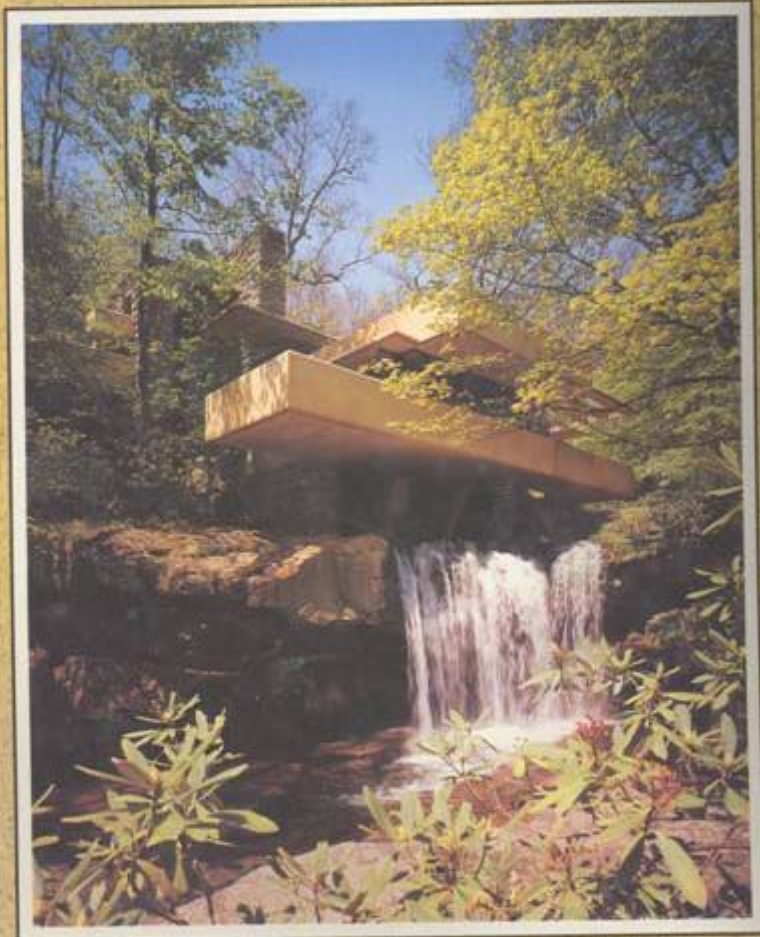

# FRANK LLOYD WRIGHT

AMERICAN ARCHITECT FOR THE TWENTIETH CENTURY

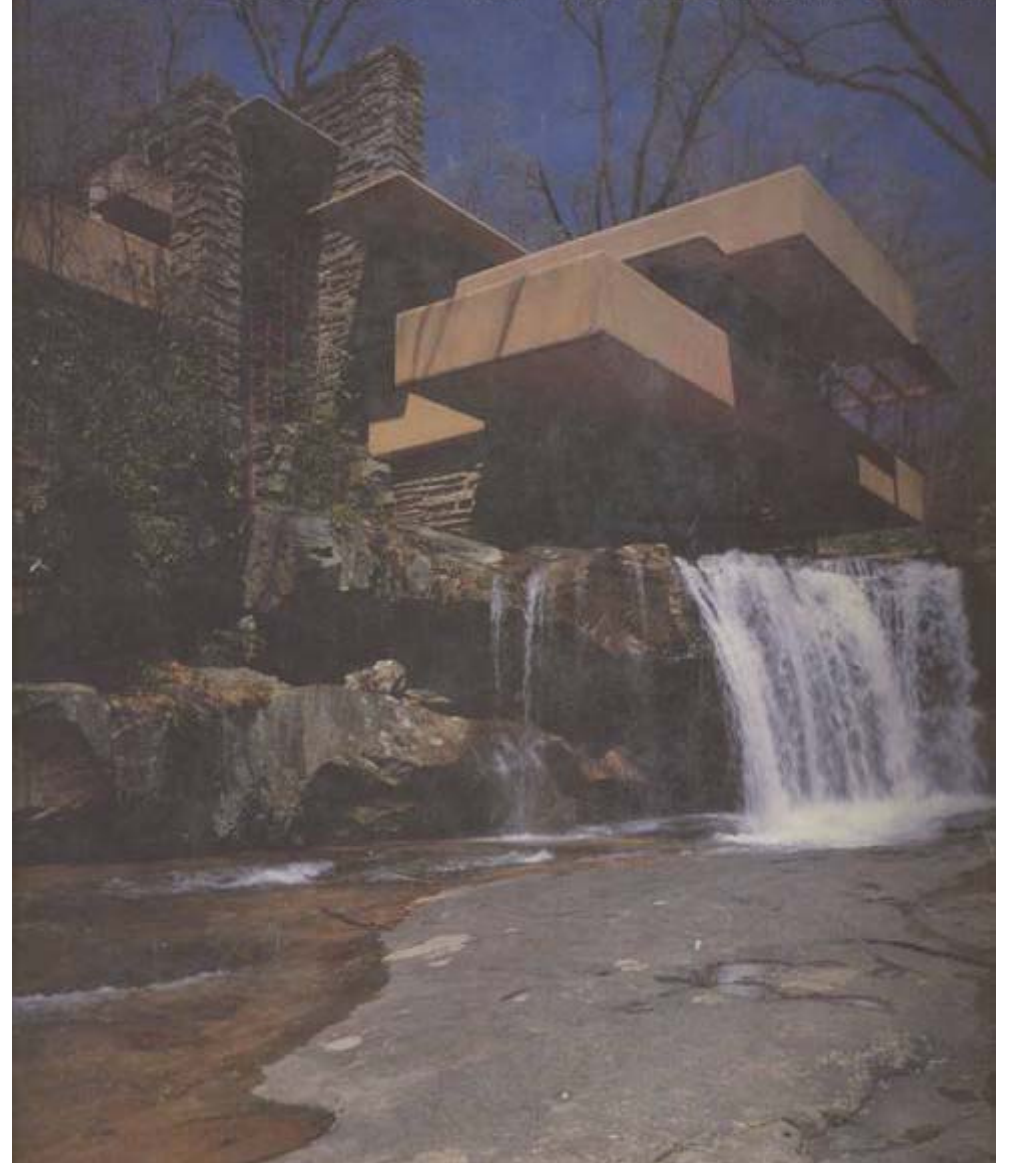

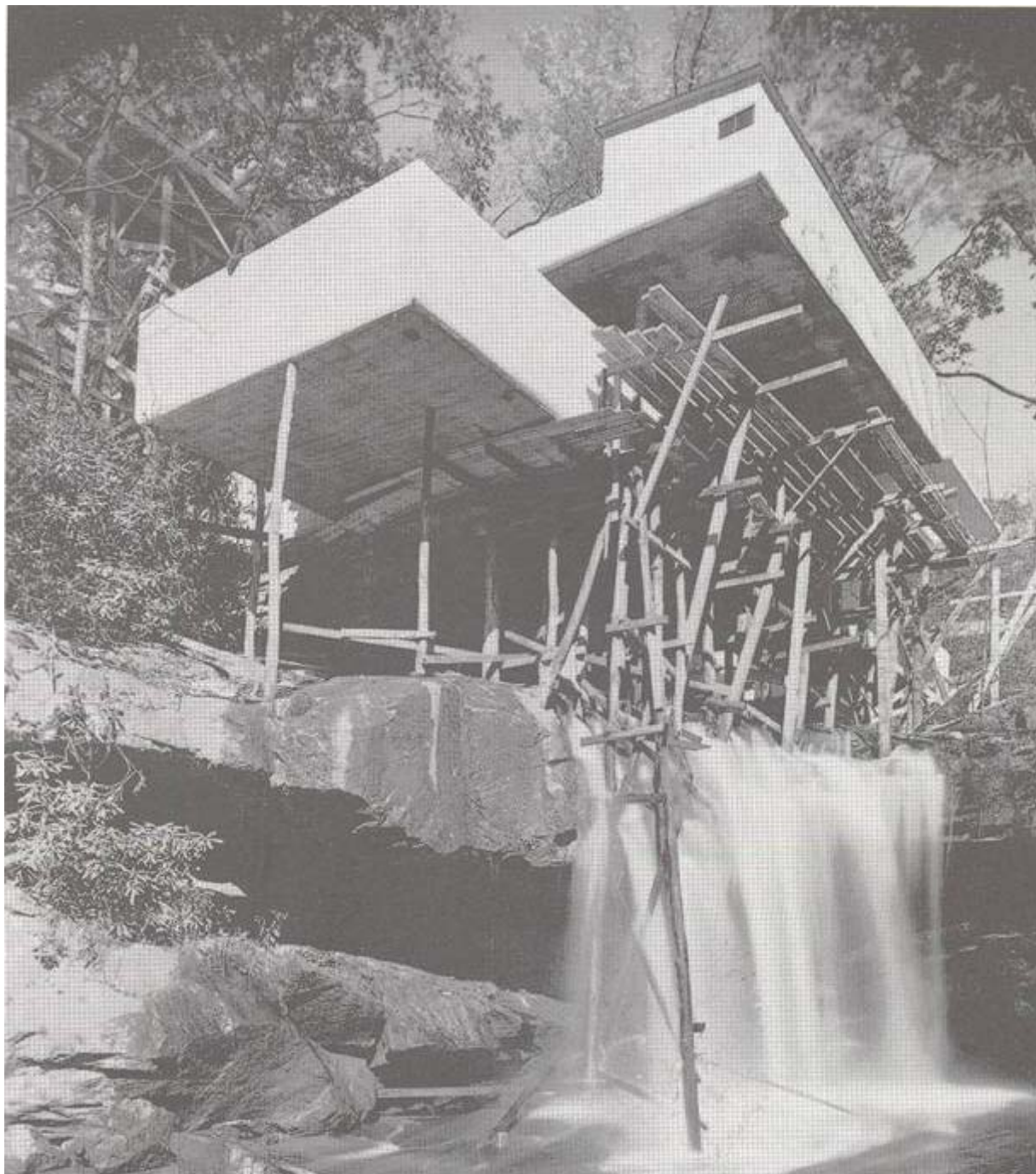

Fallingwater-u vrijeme gradnje, jesen 1936.

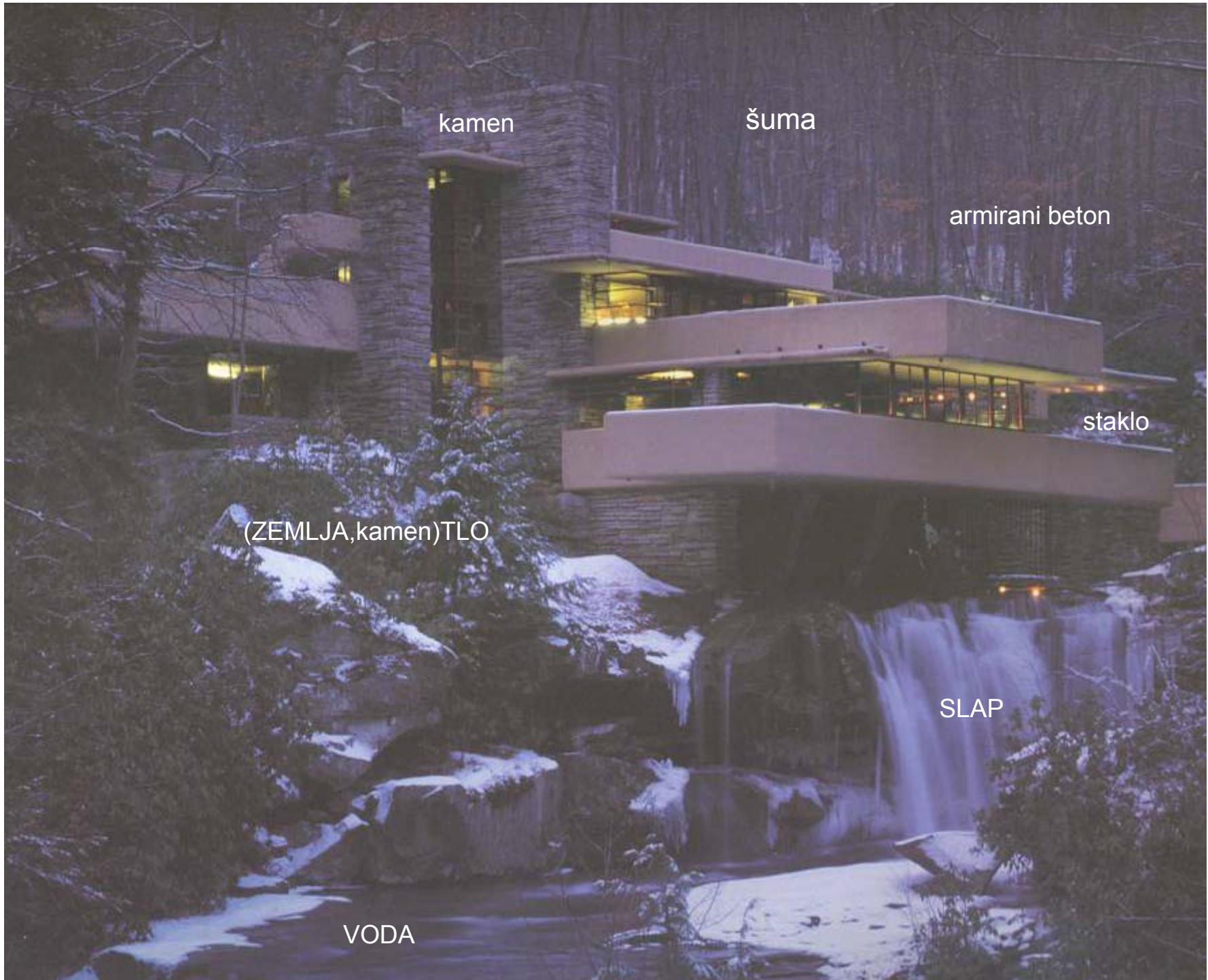

kamen

šuma

armirani beton

staklo

(ZEMLJA,kamen)TLO

SLAP

VODA

žbuka

SVJETLOST

VATRA

kameni

kamene ploče

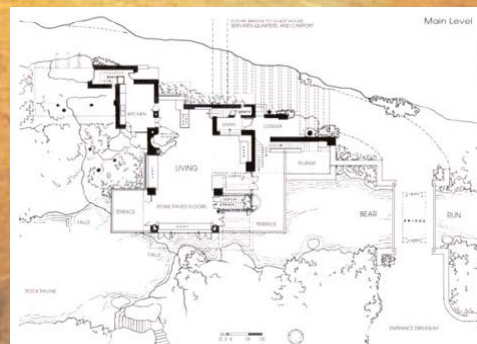

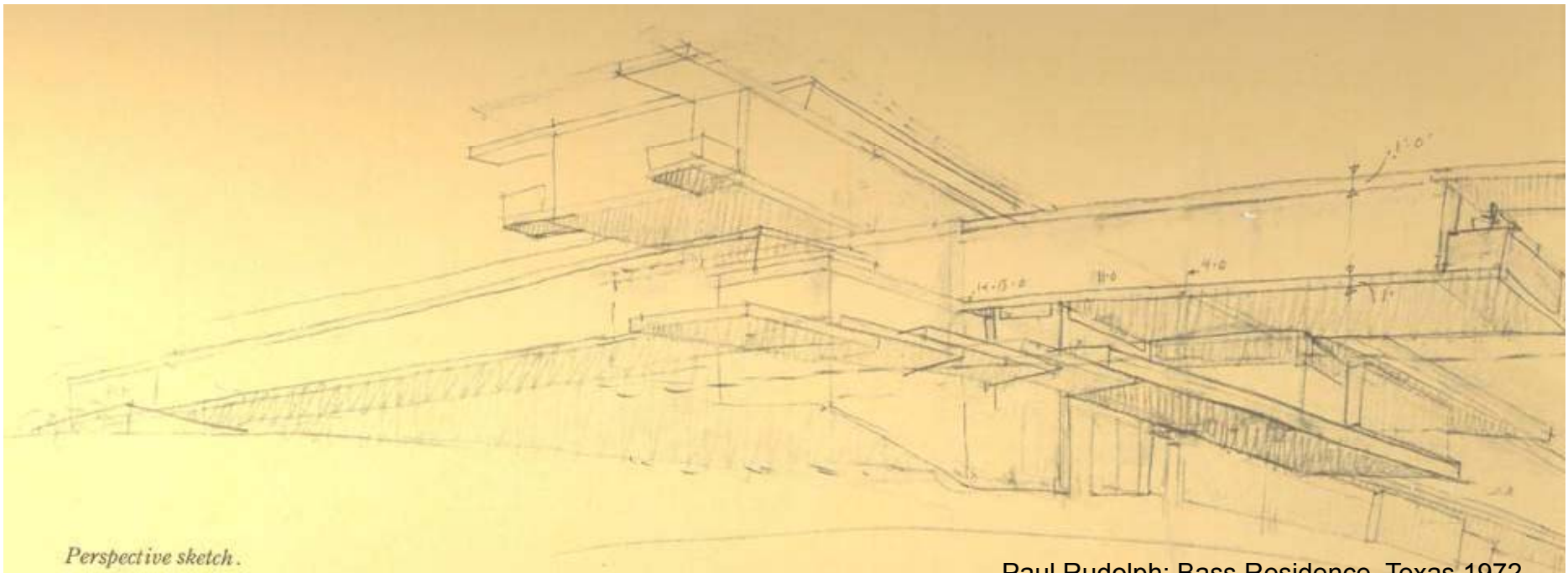
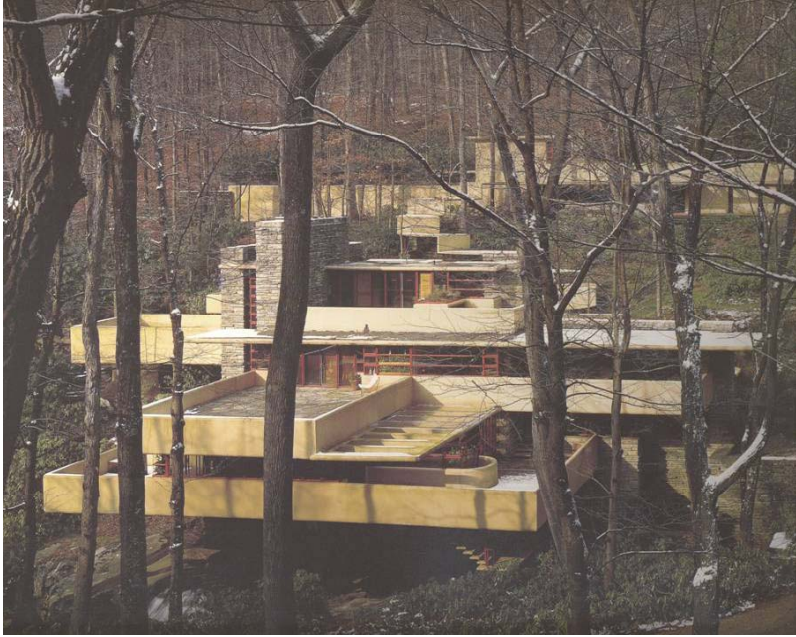

Paul Rudolph: Bass Residence, Texas, 1972.



Paul Rudolph: Bass Residence, Texas, 1972.

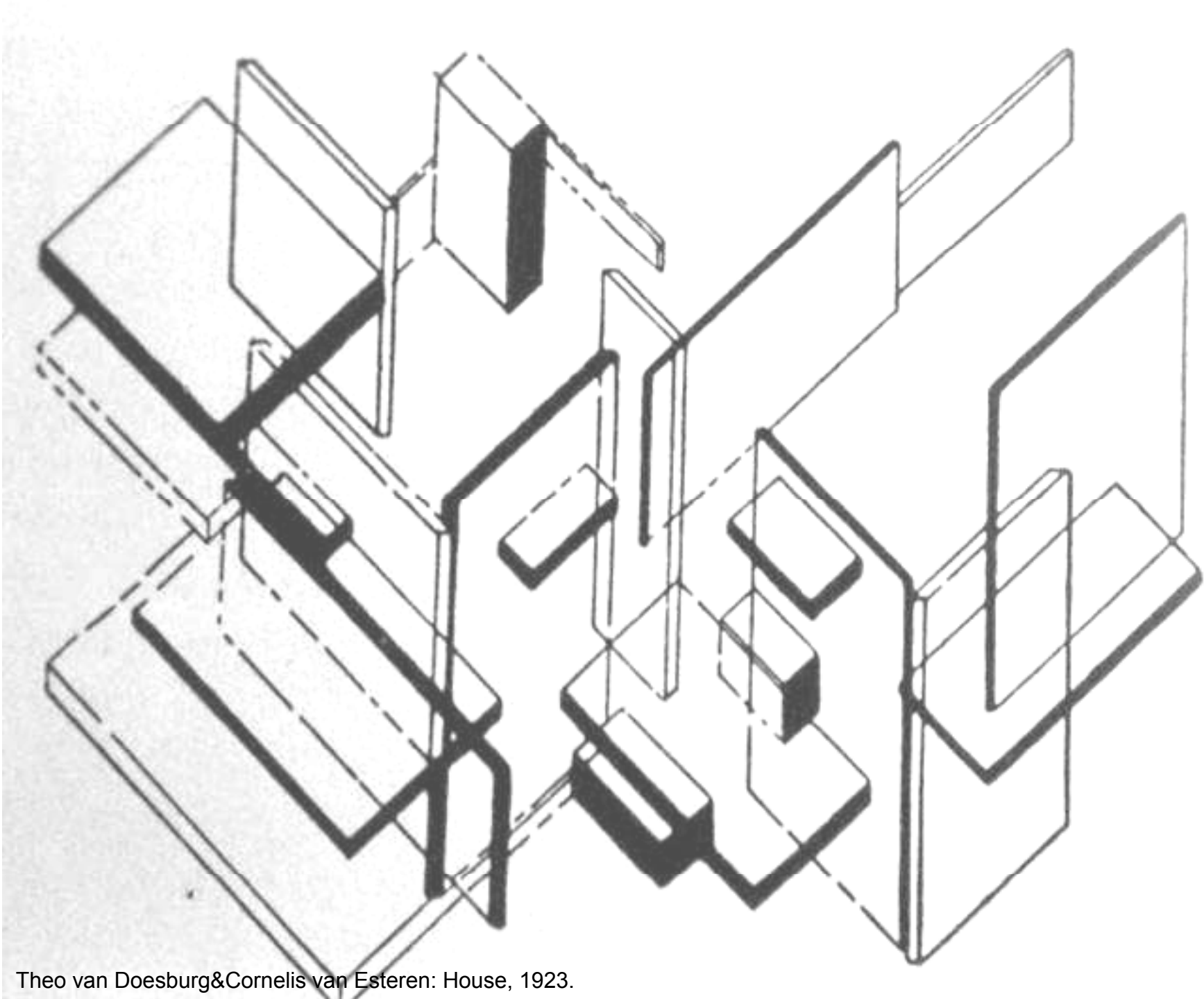

Theo van Doesburg & Cornelis van Eesteren: House, 1923.



Gerit Rietveld

**STIJL**  
1917-1931  
**DE**  
Visions of Utopia  
[www.gutenberg.org](http://www.gutenberg.org)

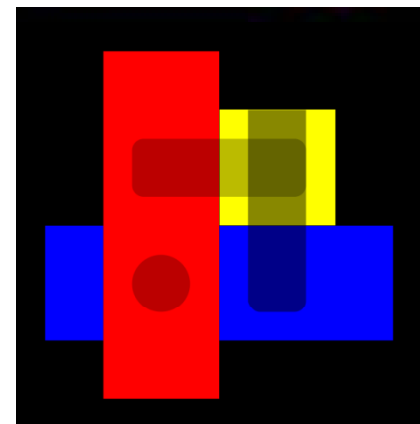
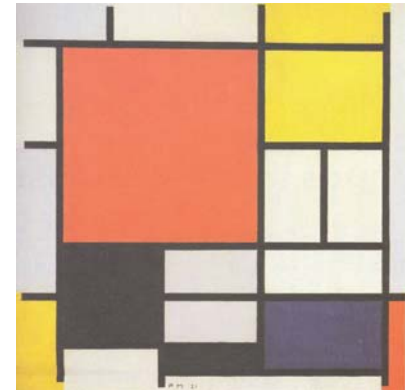
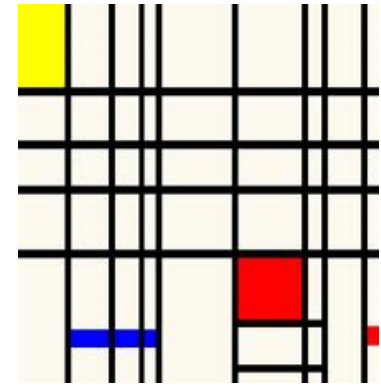

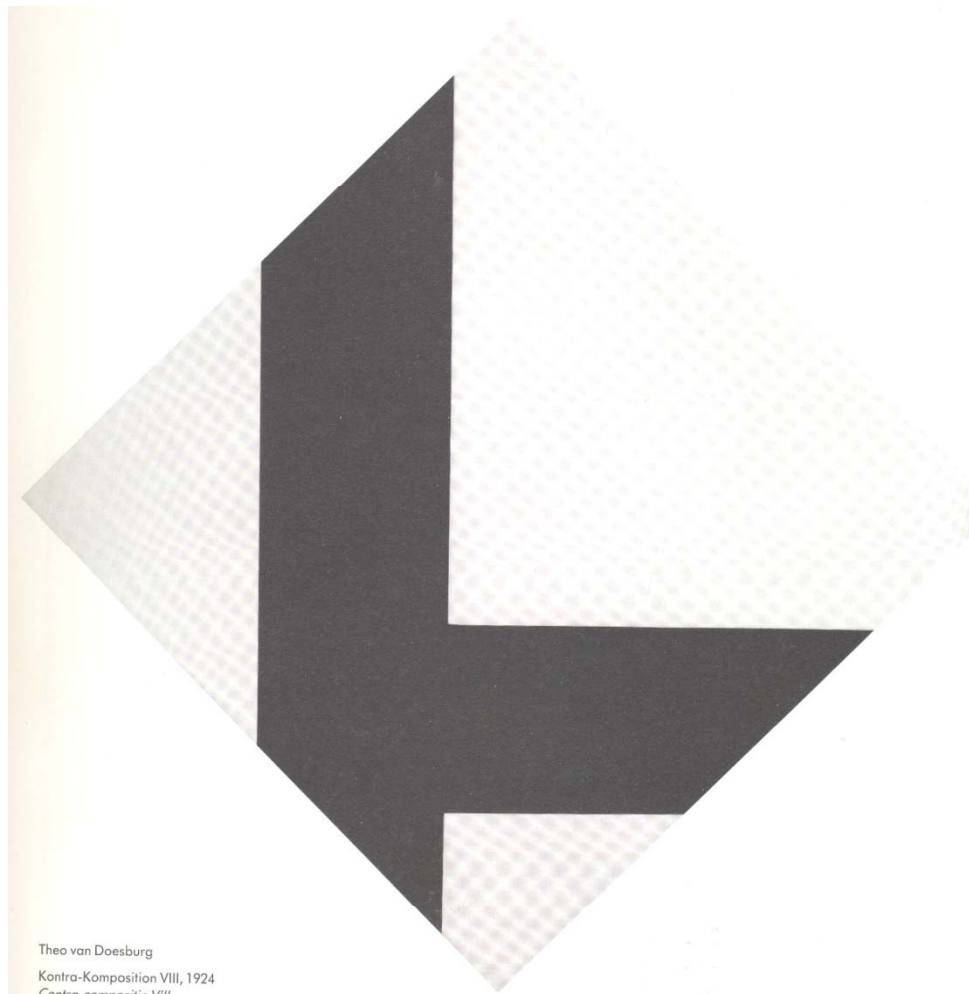

Theo van Doesburg  
Kontra-Kompositie VIII, 1924  
*Contra-compositie VIII*

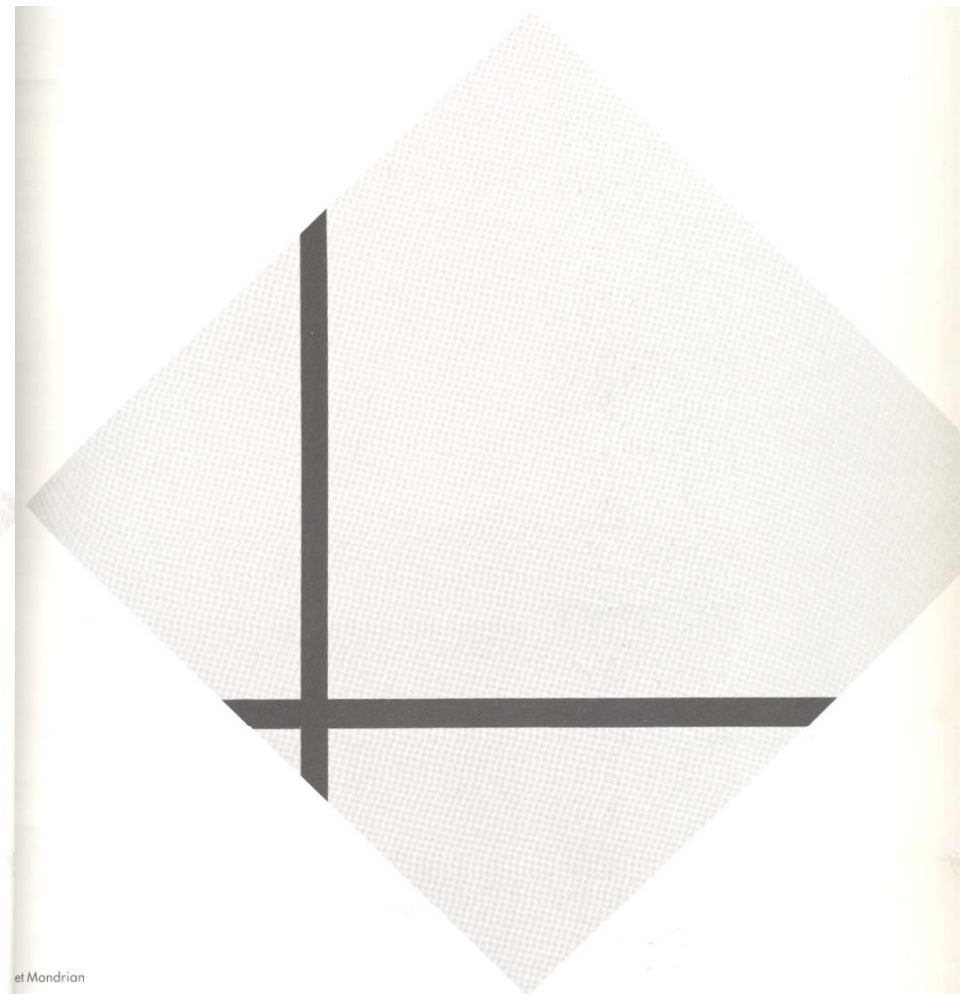

Piet Mondrian

Theo van Doesburg: Contra-Compositie VIII, 1924.

Mondrian: Compositie met twee lijnen, 1931.

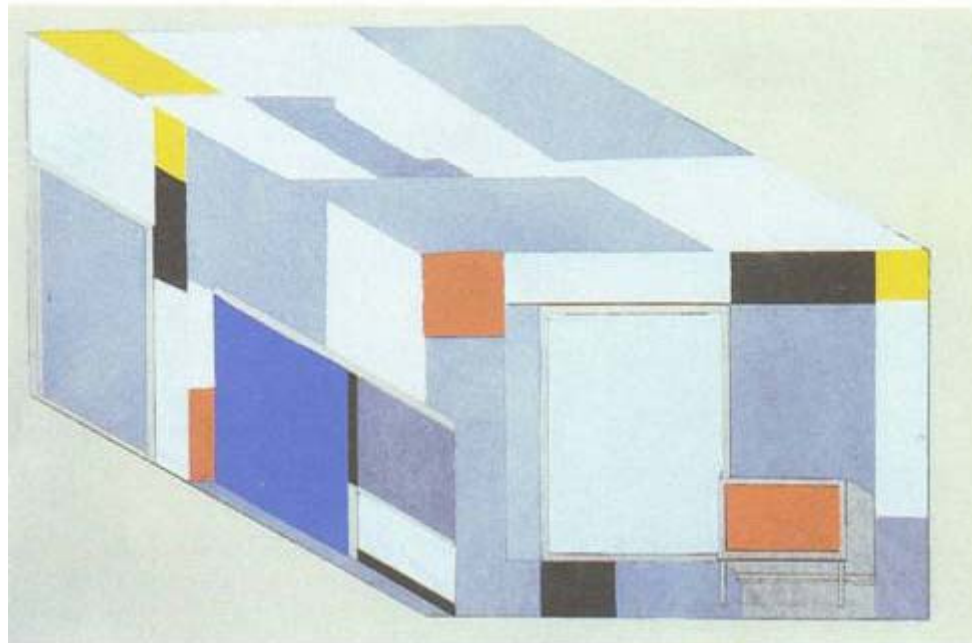
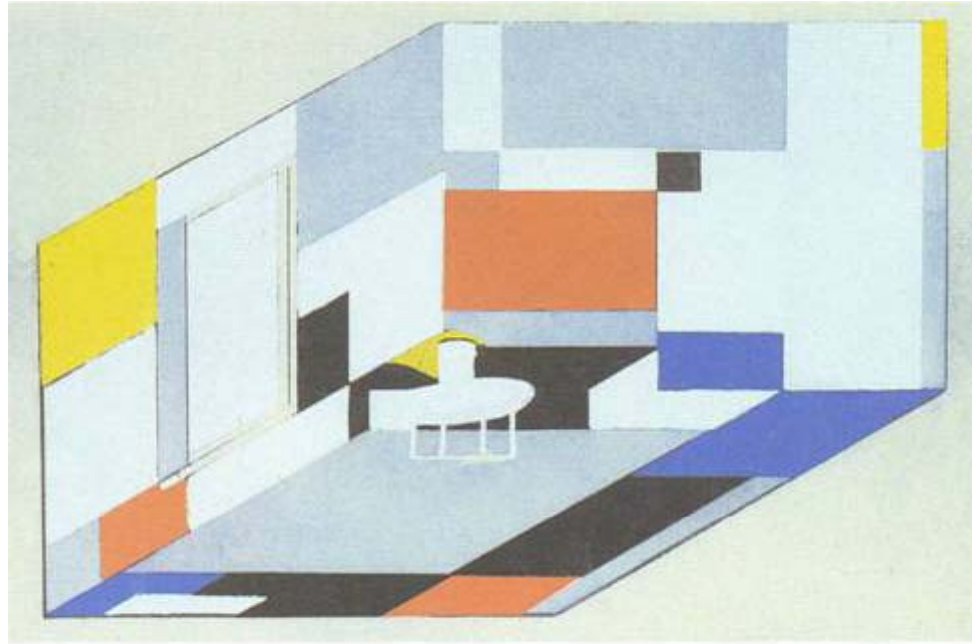

Mondrian: Ida Bienert apartman, Dresden, 1926.

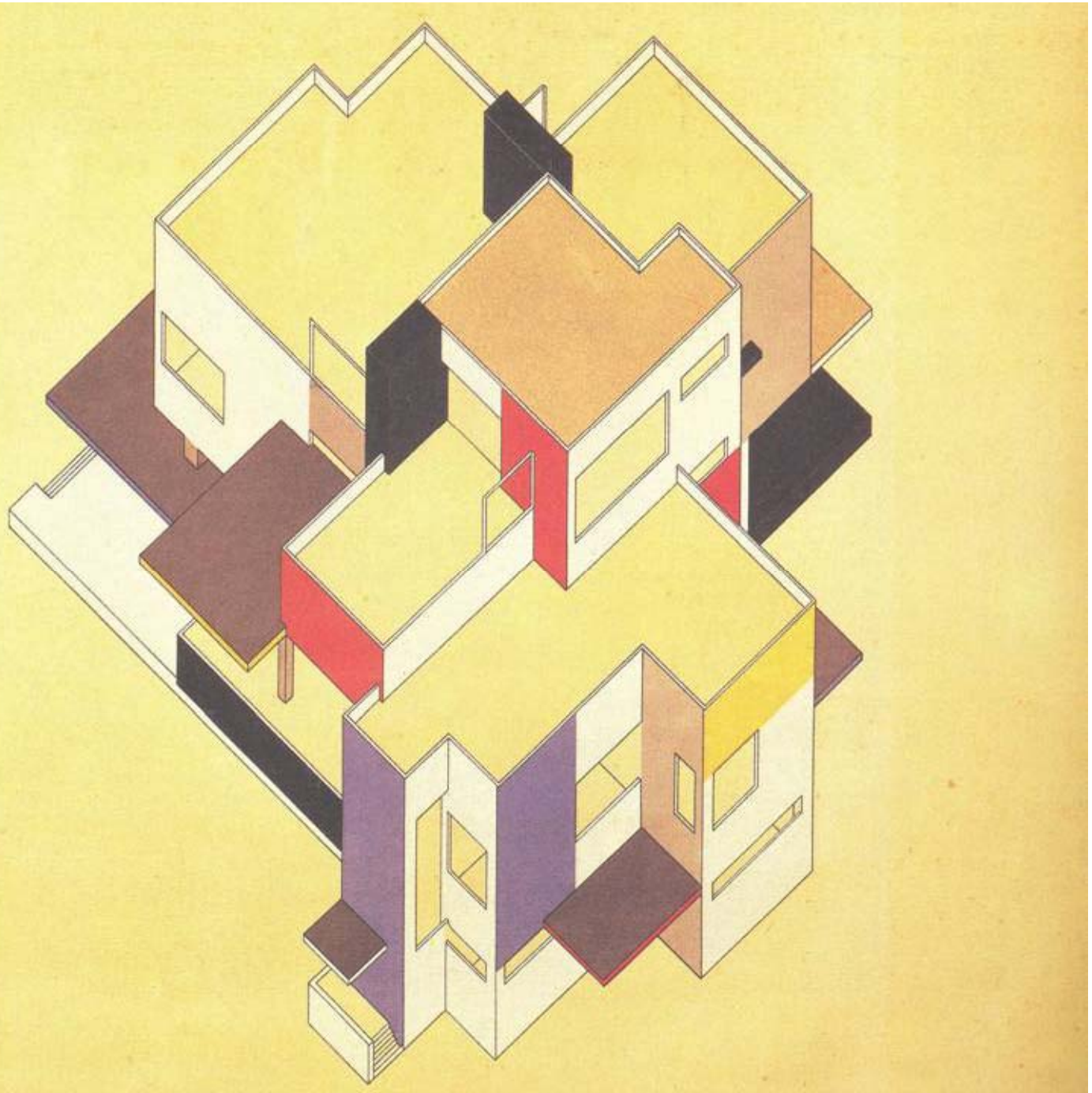

Theo van Doesburg & Cornelis van Eesteren :Maison particuliere, 1923.

# Dionizijevska kompozicija

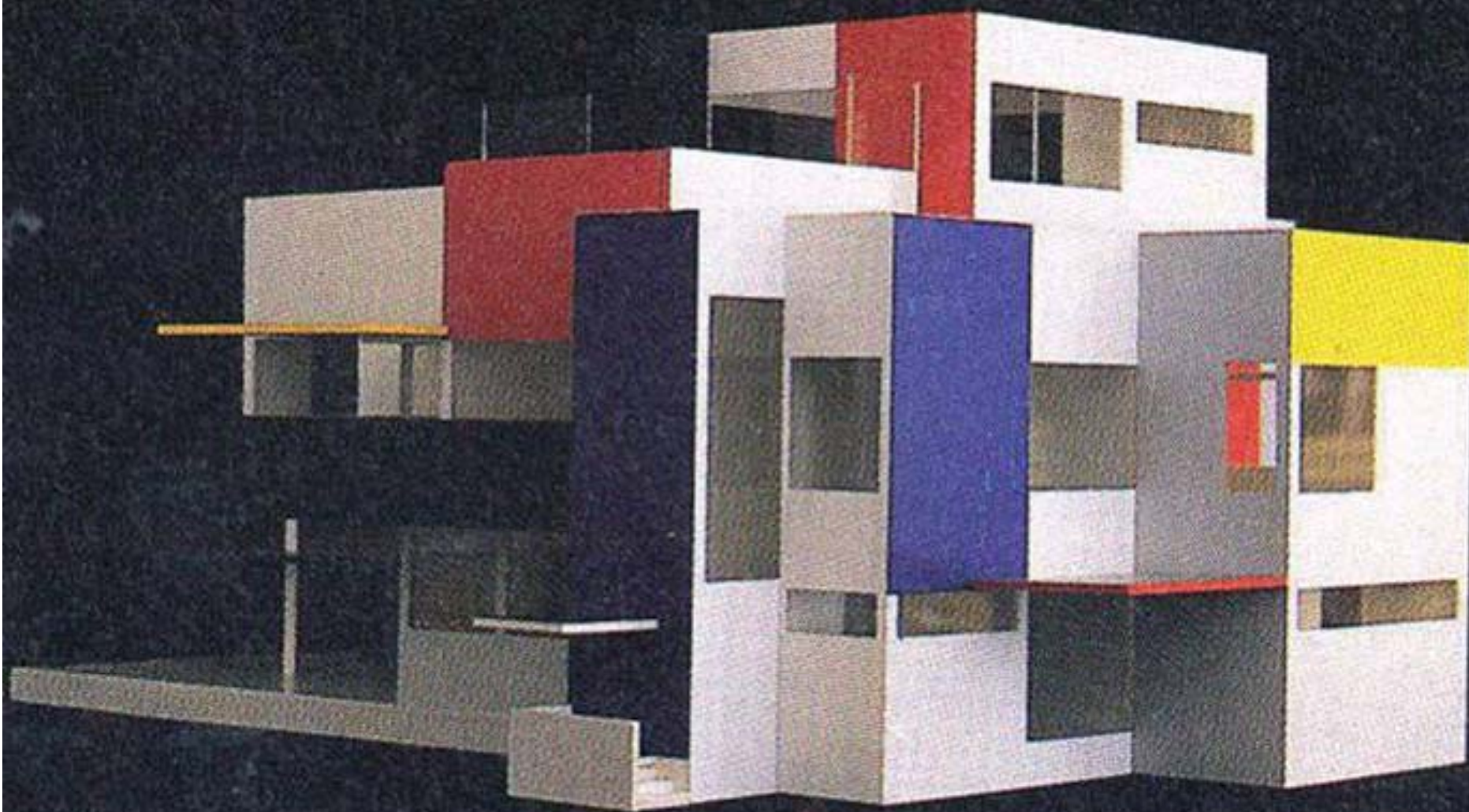

Theo van Doesburg & Cornelis van Eesteren: Maison particuliere, 1923.

NY-5, New York Five = "whites", 1972.

**Peter Eisenman**

**John Hejduk**

**Michael Graves**

**Charles Gwathmey**

**Richard Meier**

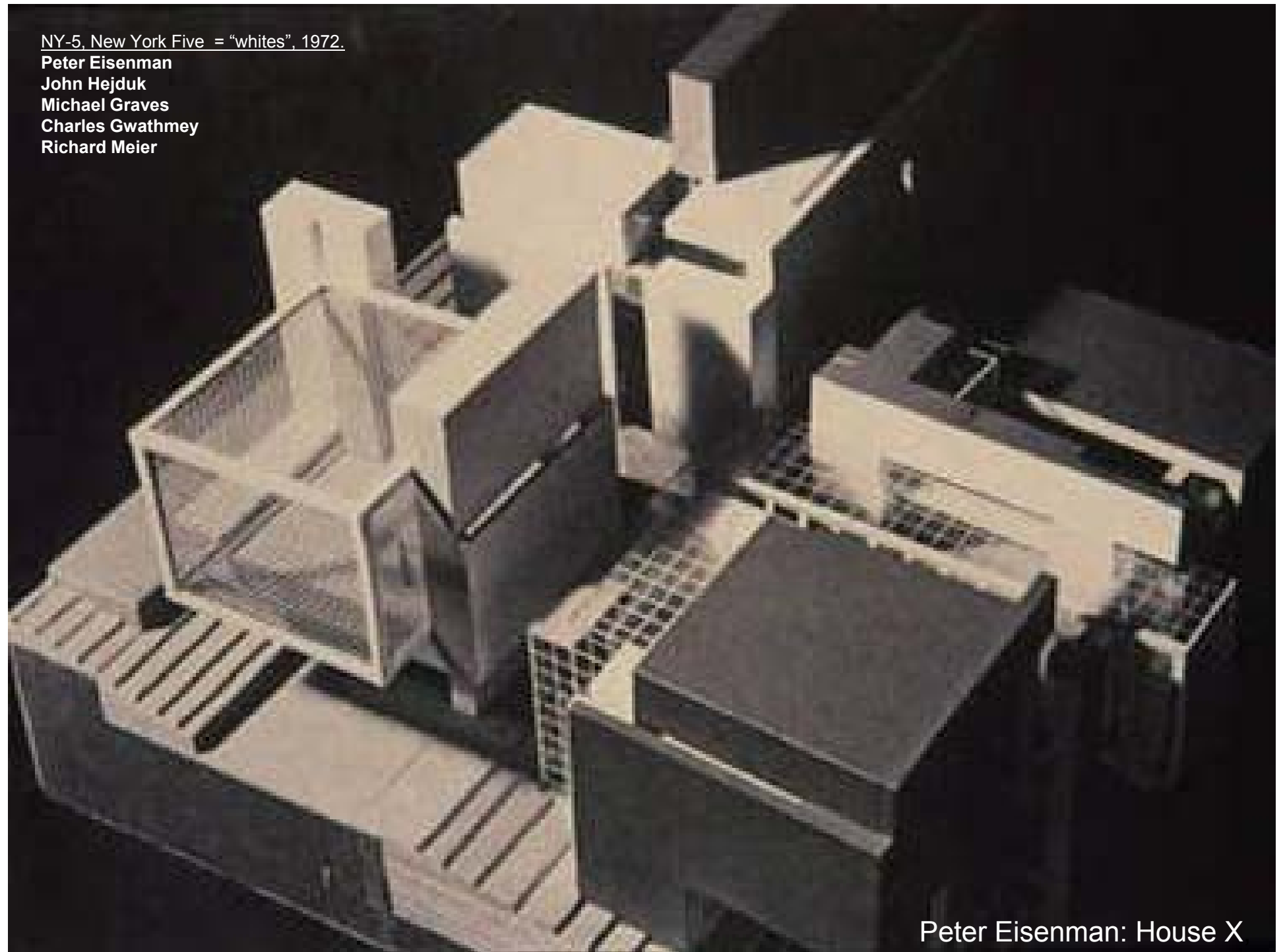

Peter Eisenman: House X

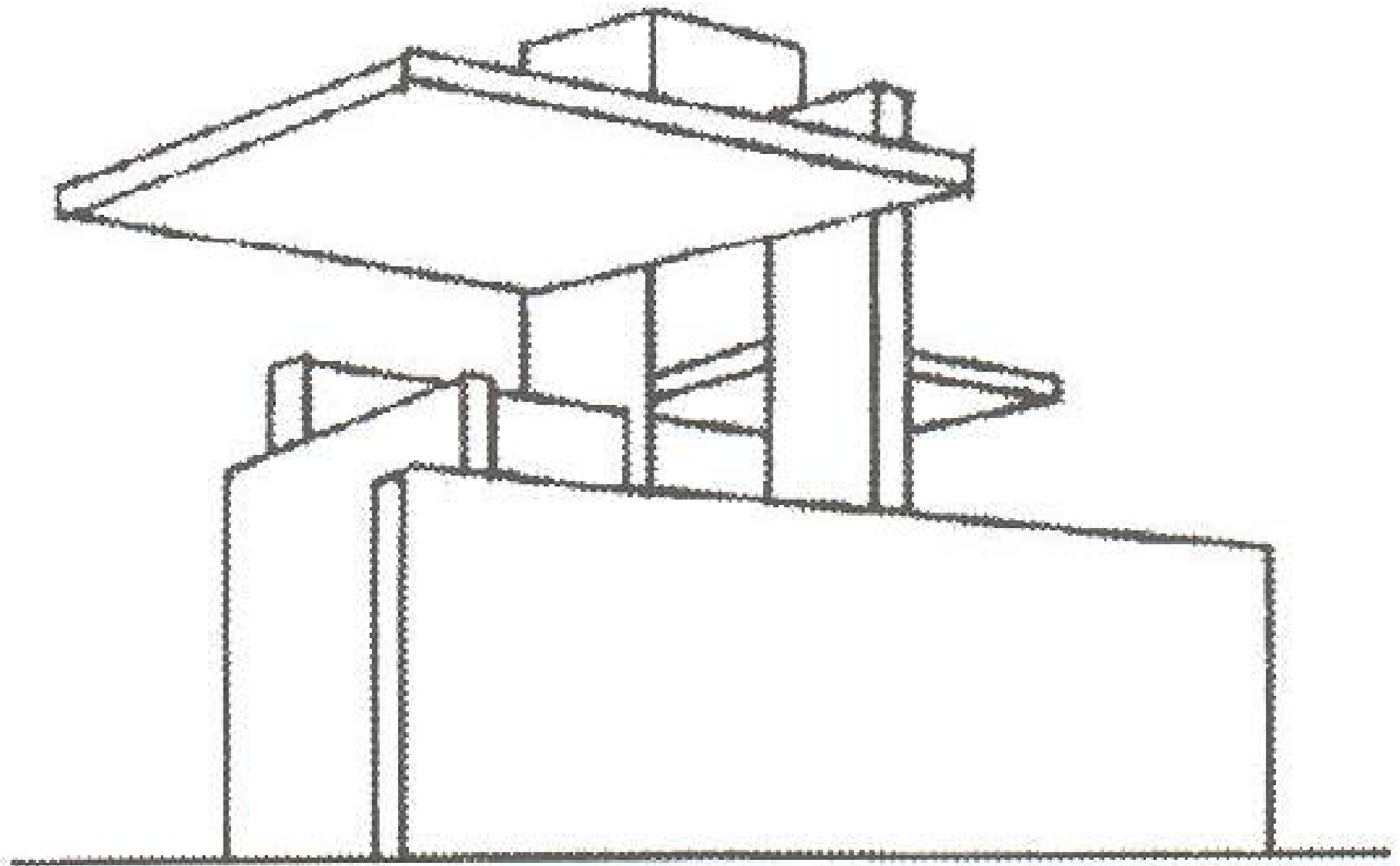

Transformatorska stanica, 1925.

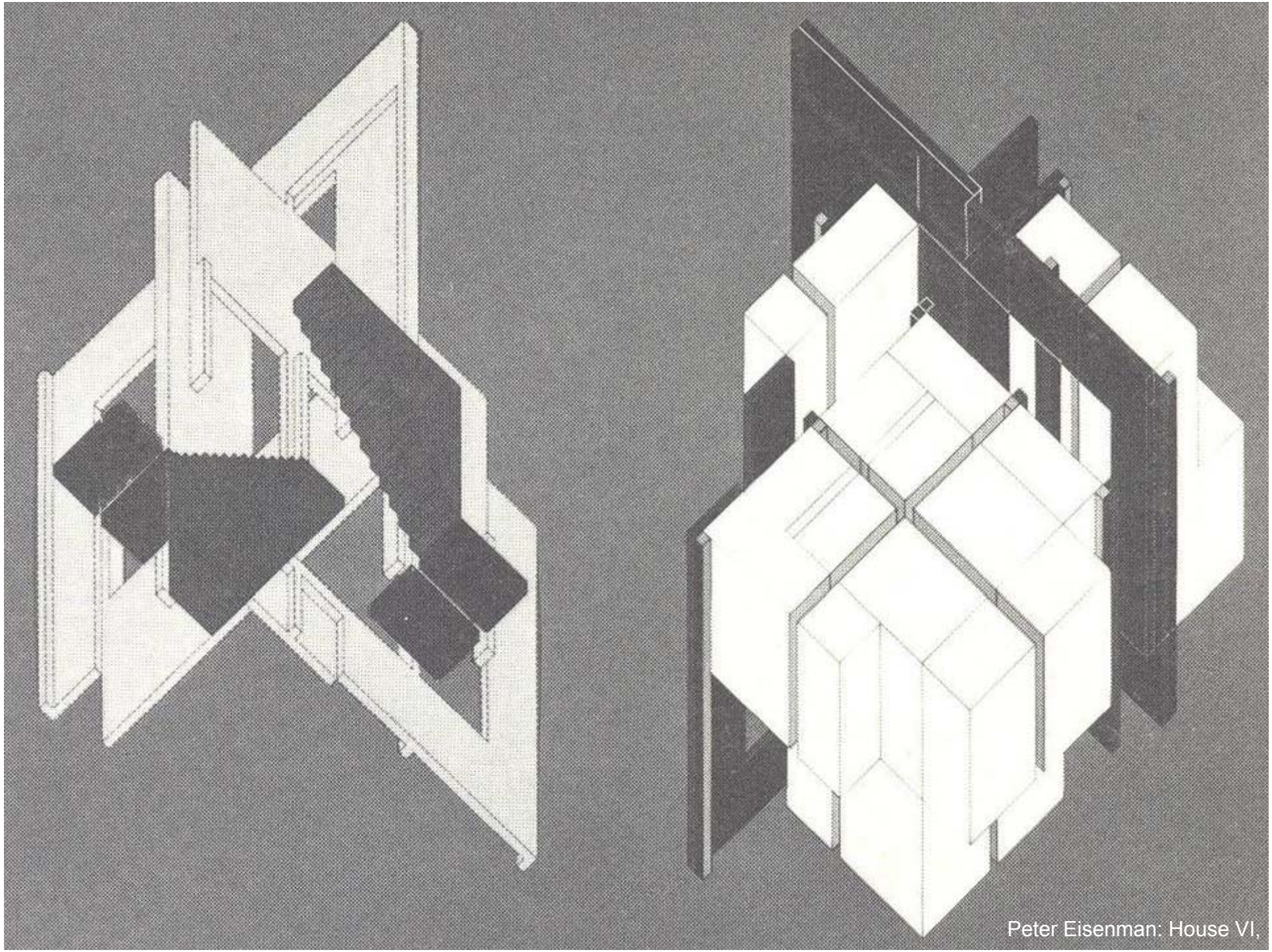

Peter Eisenman: House VI,



NY-5, New York Five = "whites", 1972.

**Peter Eisenman**

**John Hejduk**

**Michael Graves**

**Charles Gwathmey**

**Richard Meier**

Peter Eisenman: House VI



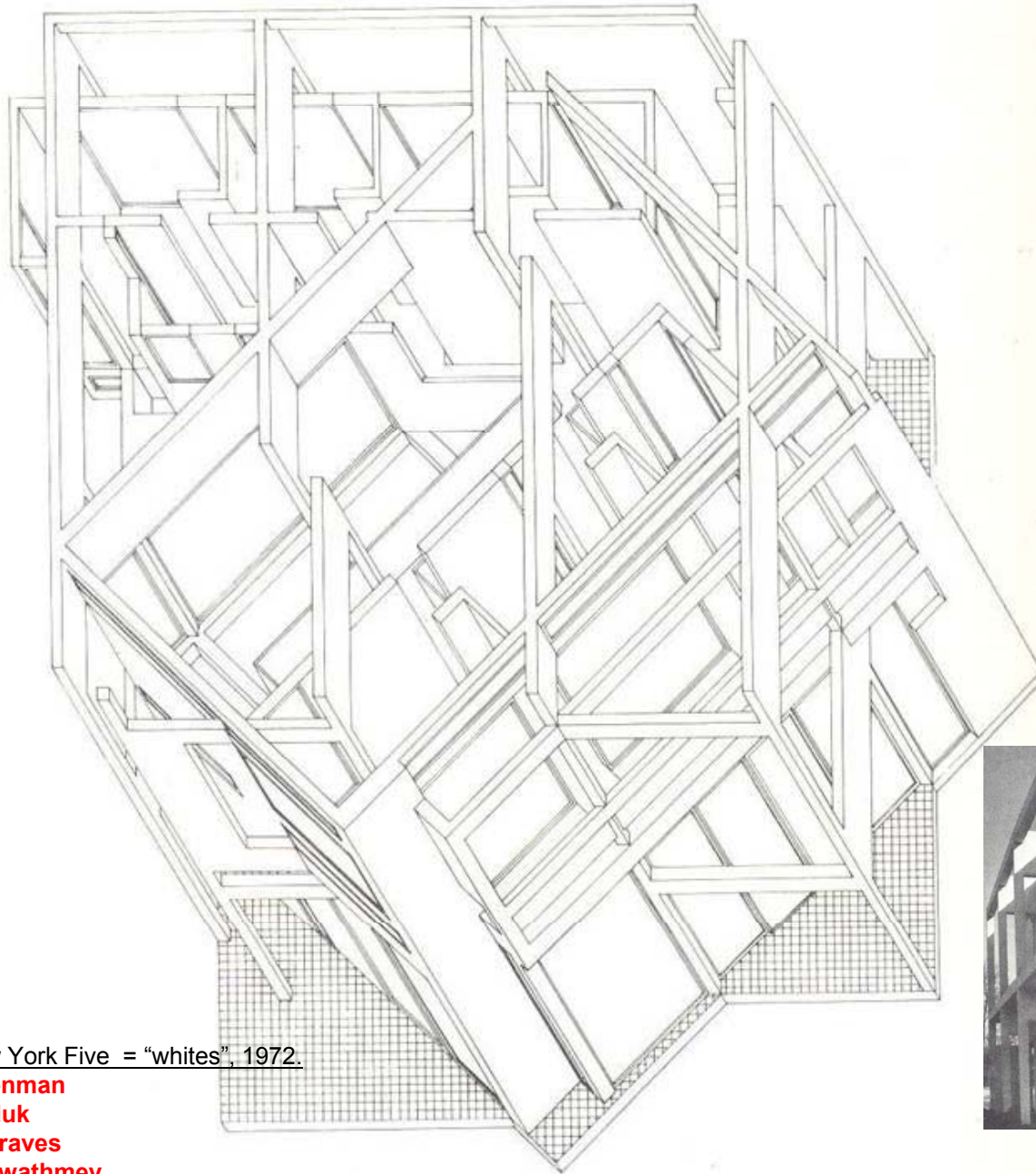

NY-5, New York Five = "whites", 1972.

**Peter Eisenman**  
**John Hejduk**  
**Michael Graves**  
**Charles Gwathmey**  
**Richard Meier**

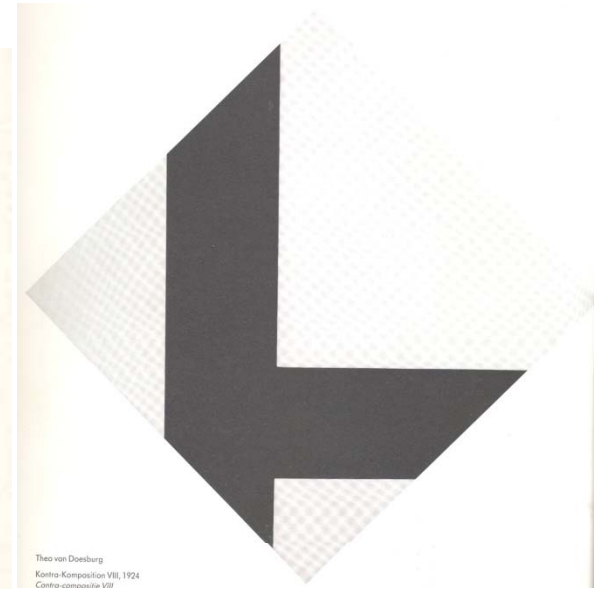

Theo van Doesburg  
Kontra-Komposition VIII, 1924  
Contra-compositie VIII



© Mondrian

Peter Eisenman: House III

van Doesburg

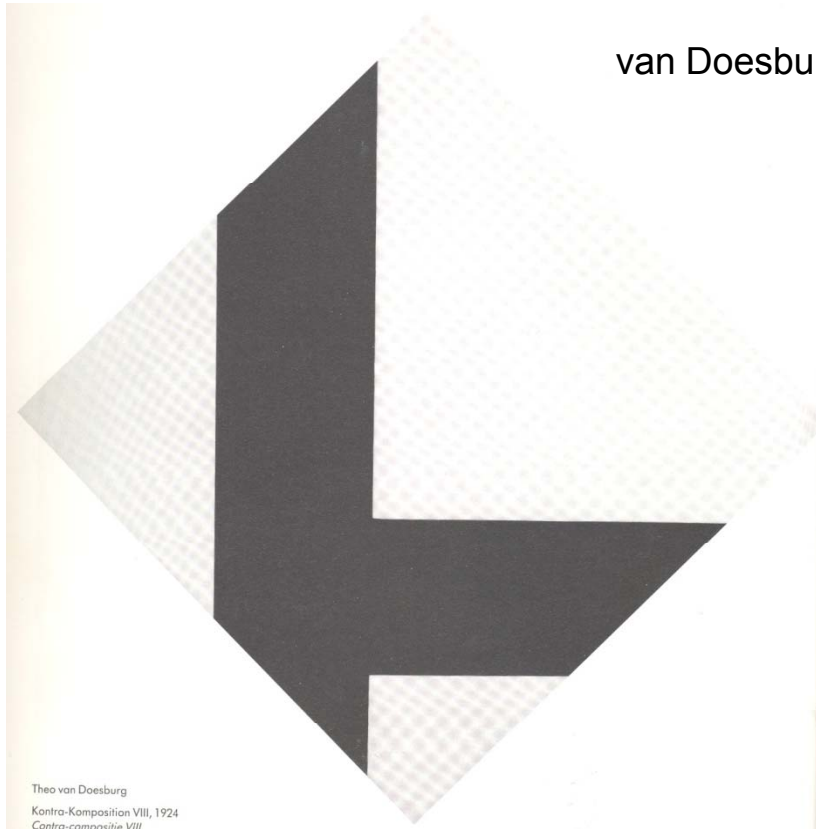

Theo van Doesburg  
Kontra-Komposition VIII, 1924  
*Contra-composition VIII*

Mondrian

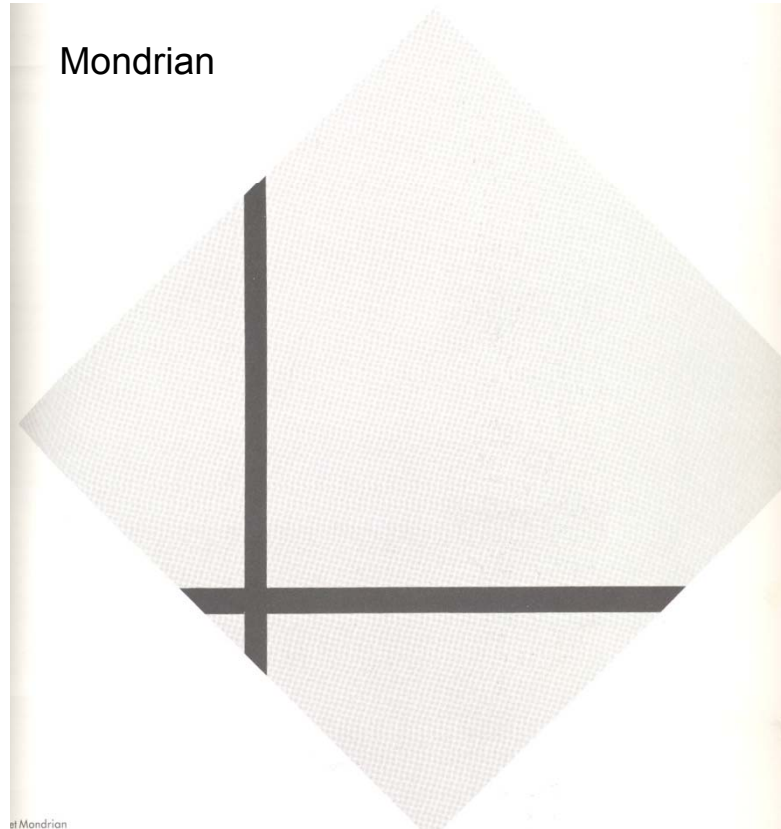

elMondrian

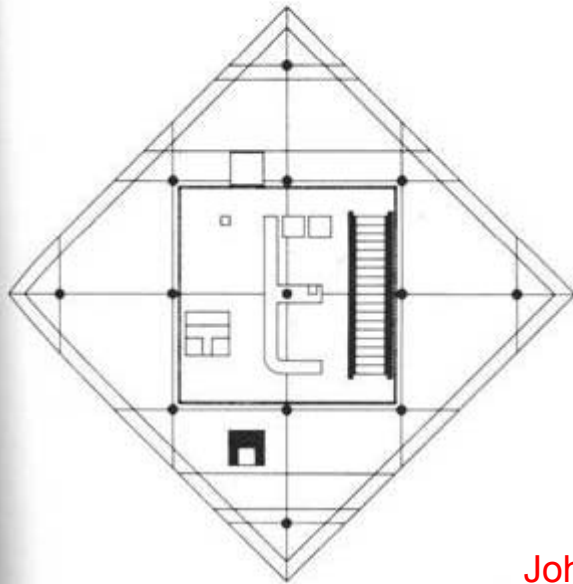

John Hejduk:

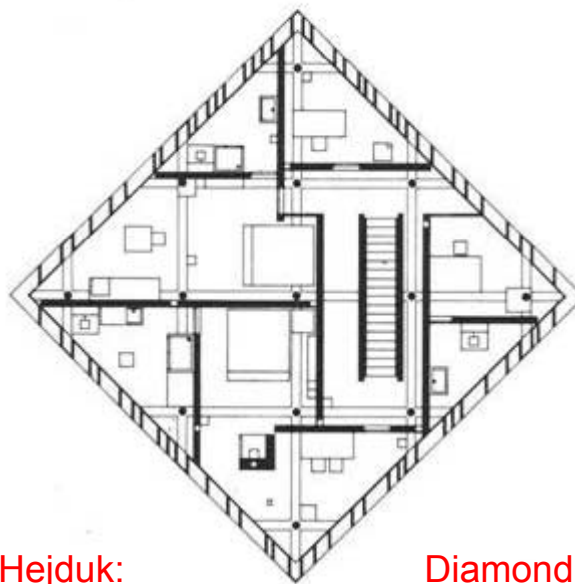

Diamond house, 1968.

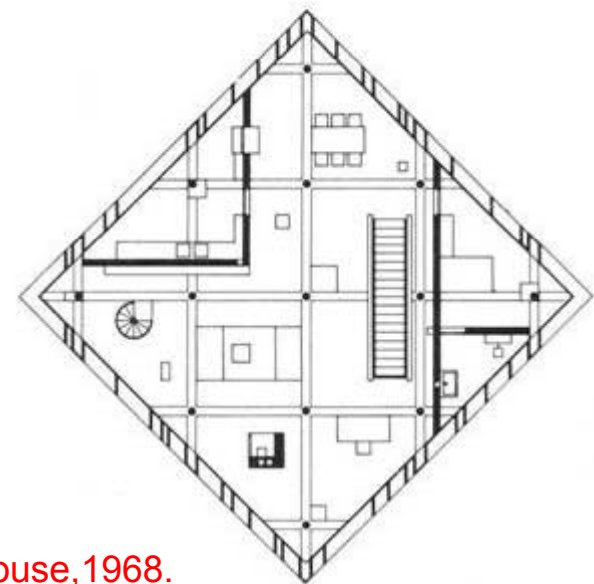

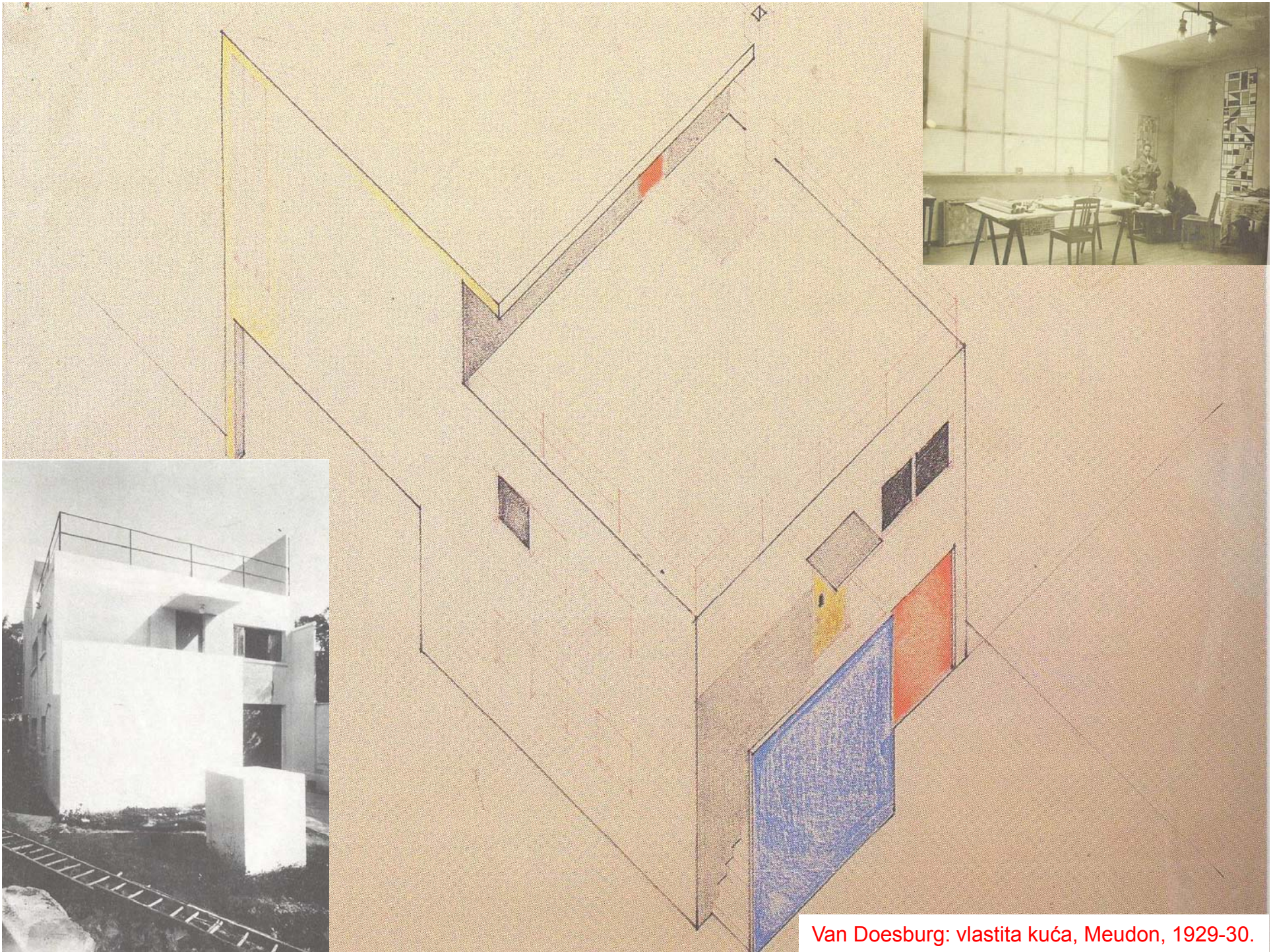

Van Doesburg: vlastita kuća, Meudon, 1929-30.

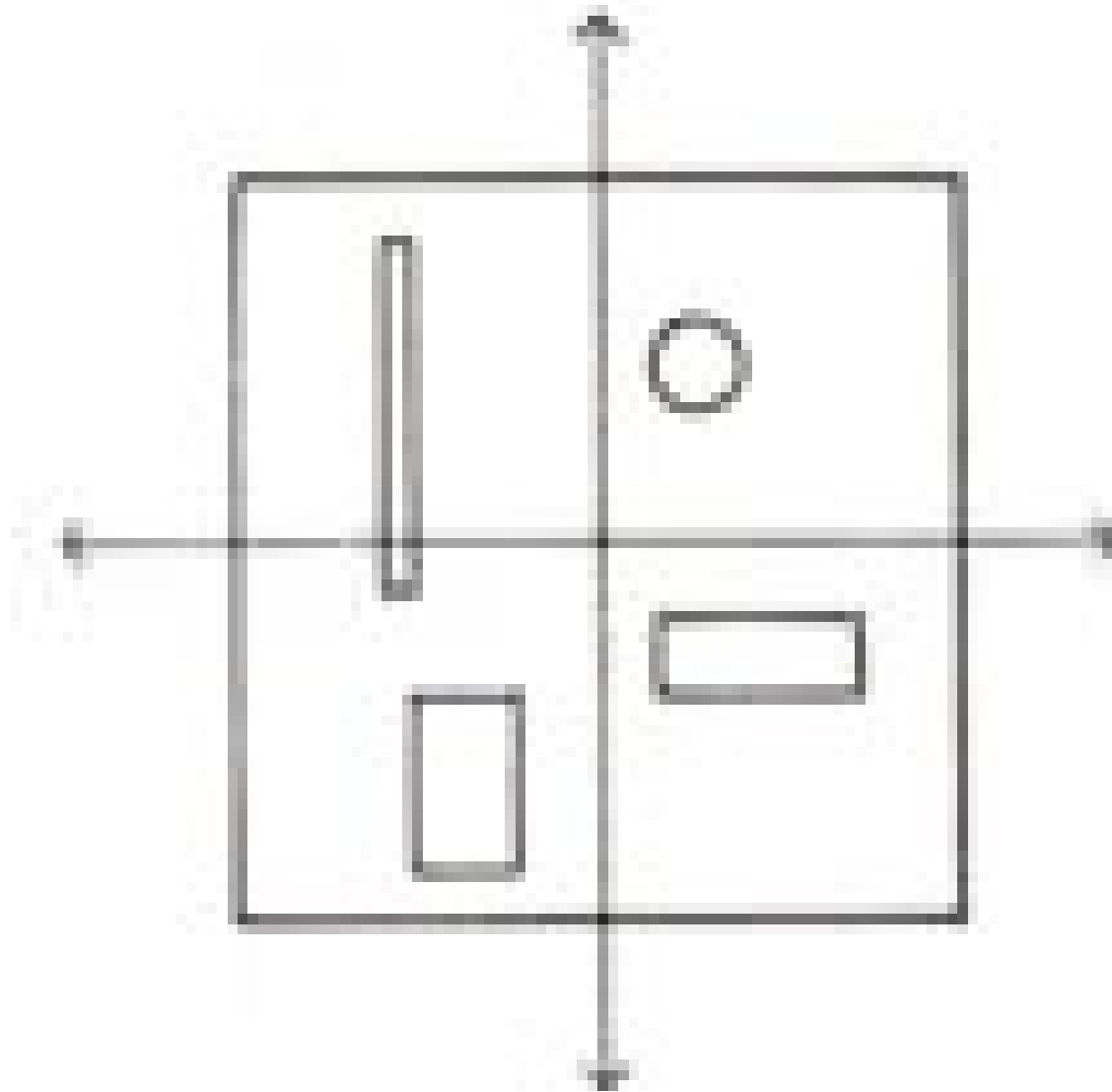

# DE STIJL

/nema gravitacije/

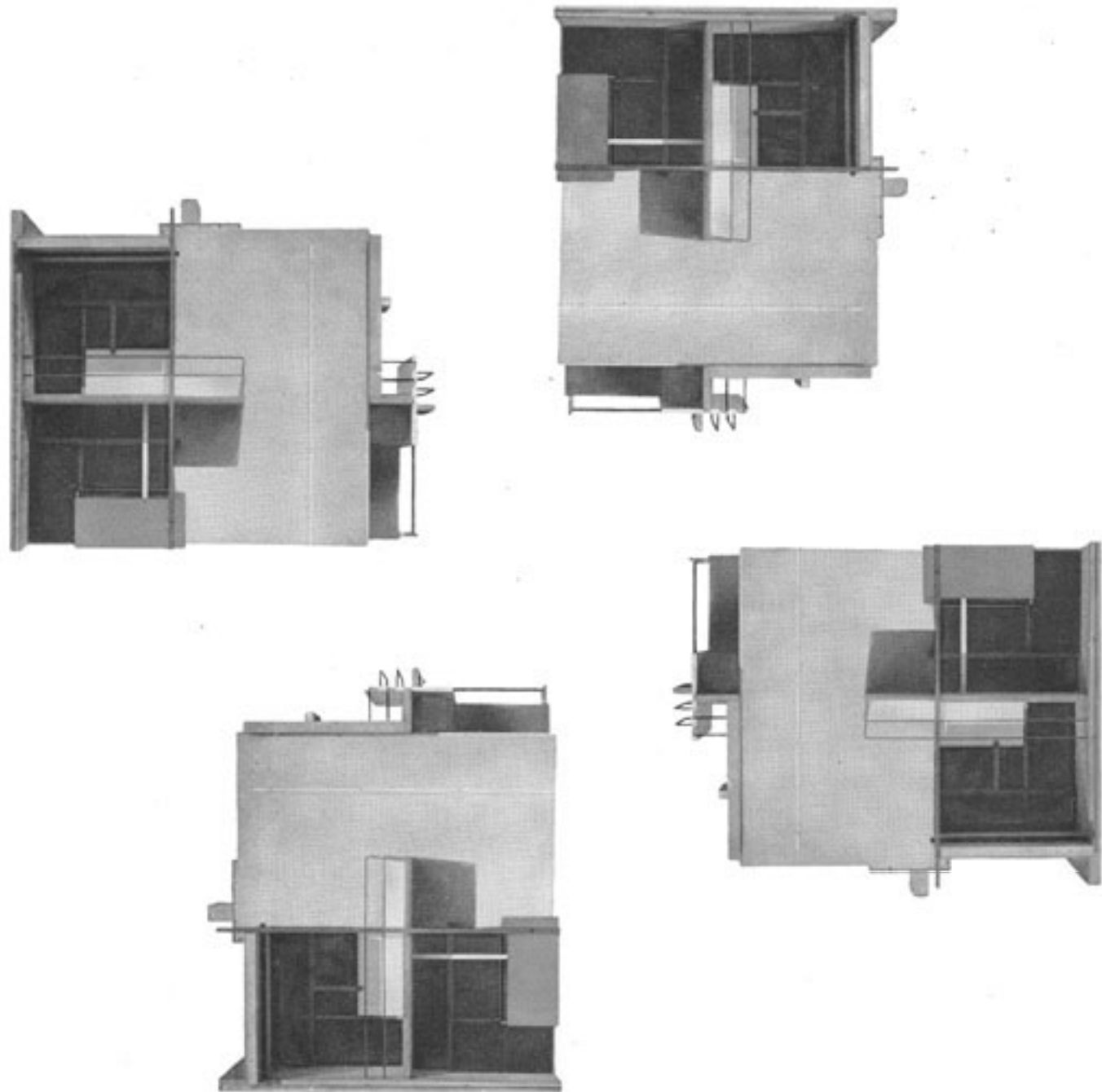
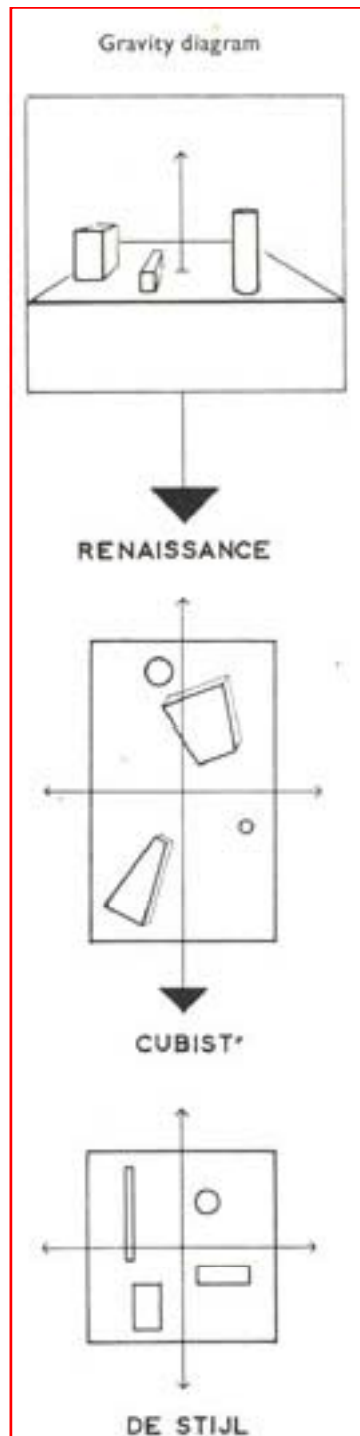

Schröder House, south-west, 1924

**DE STIJL**

# SCHRODER HOUSE, UTRECHT, 1924/5

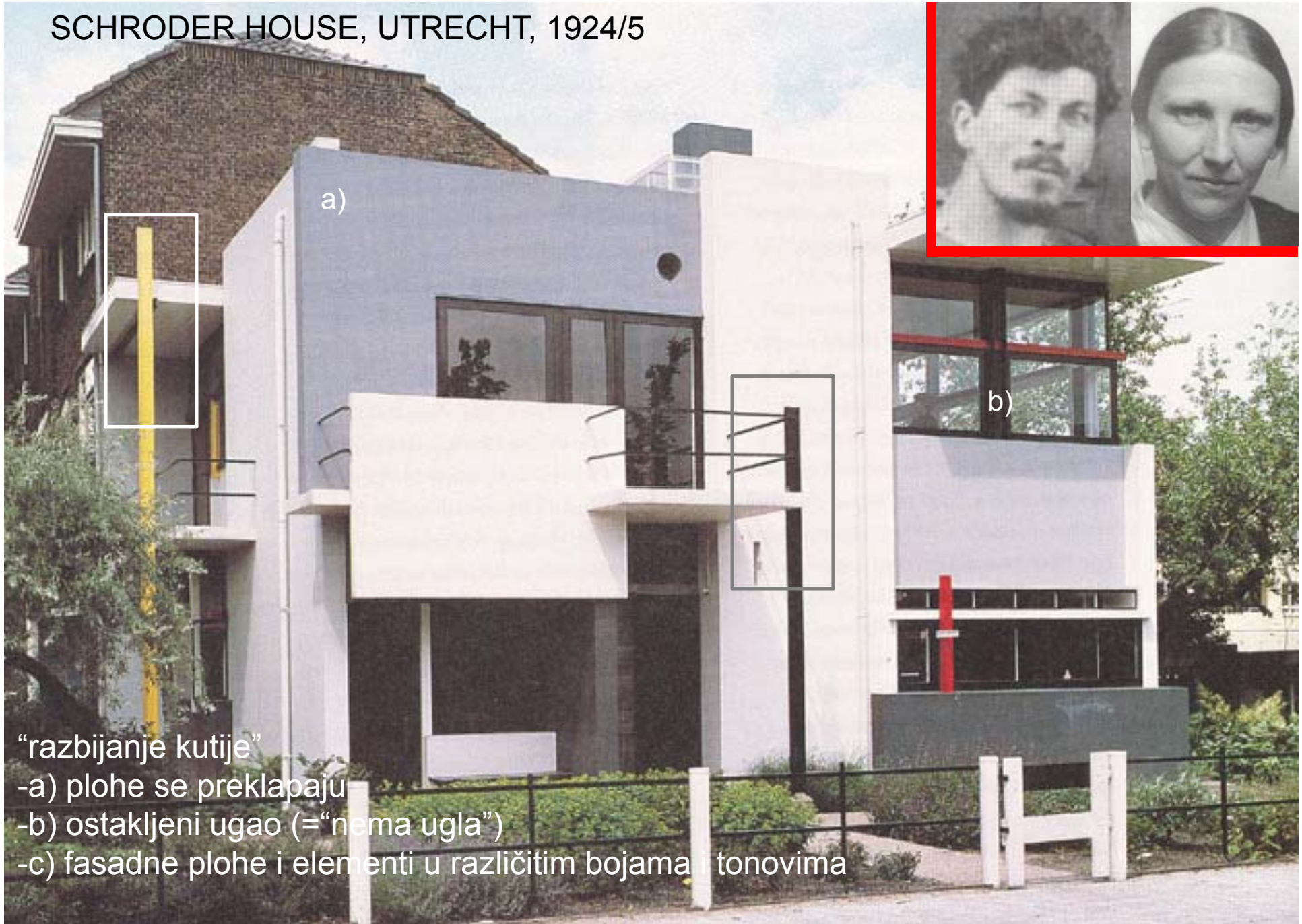

“razbijanje kutije”

- a) plohe se preklapaju
- b) ostakljeni ugao (=“nema ugla”)
- c) fasadne plohe i elementi u različitim bojama i tonovima

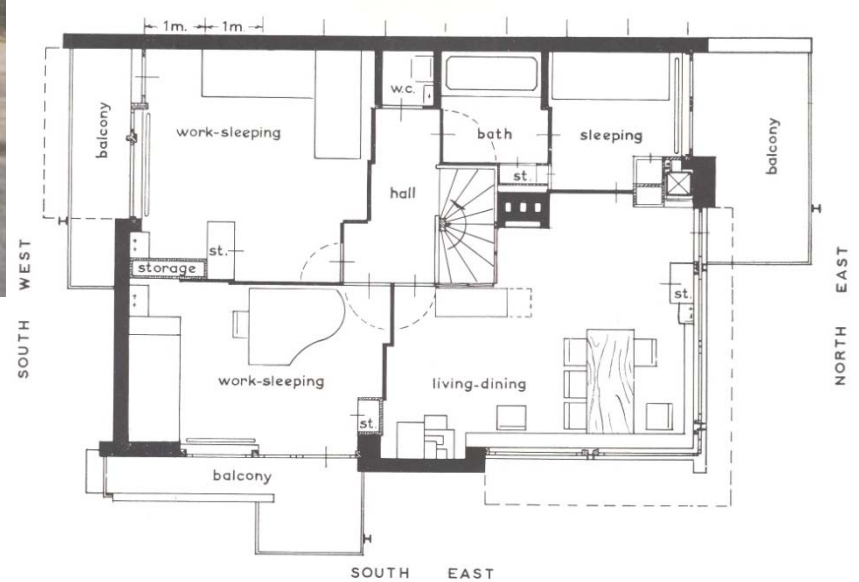
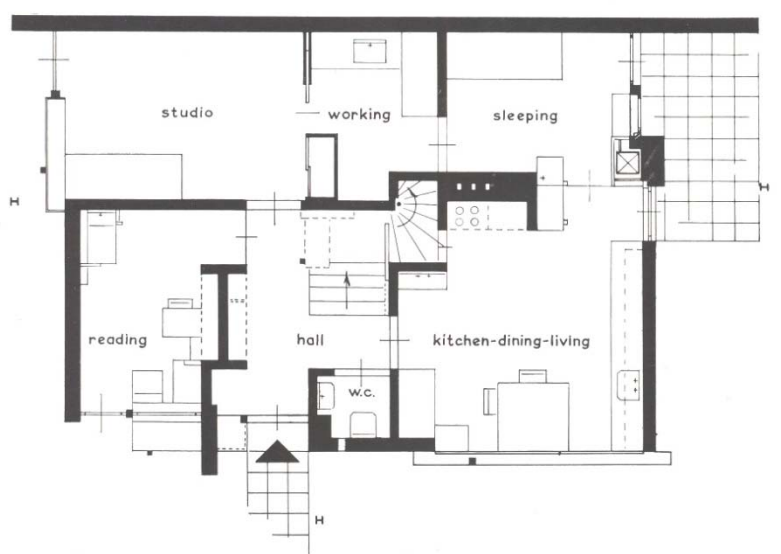

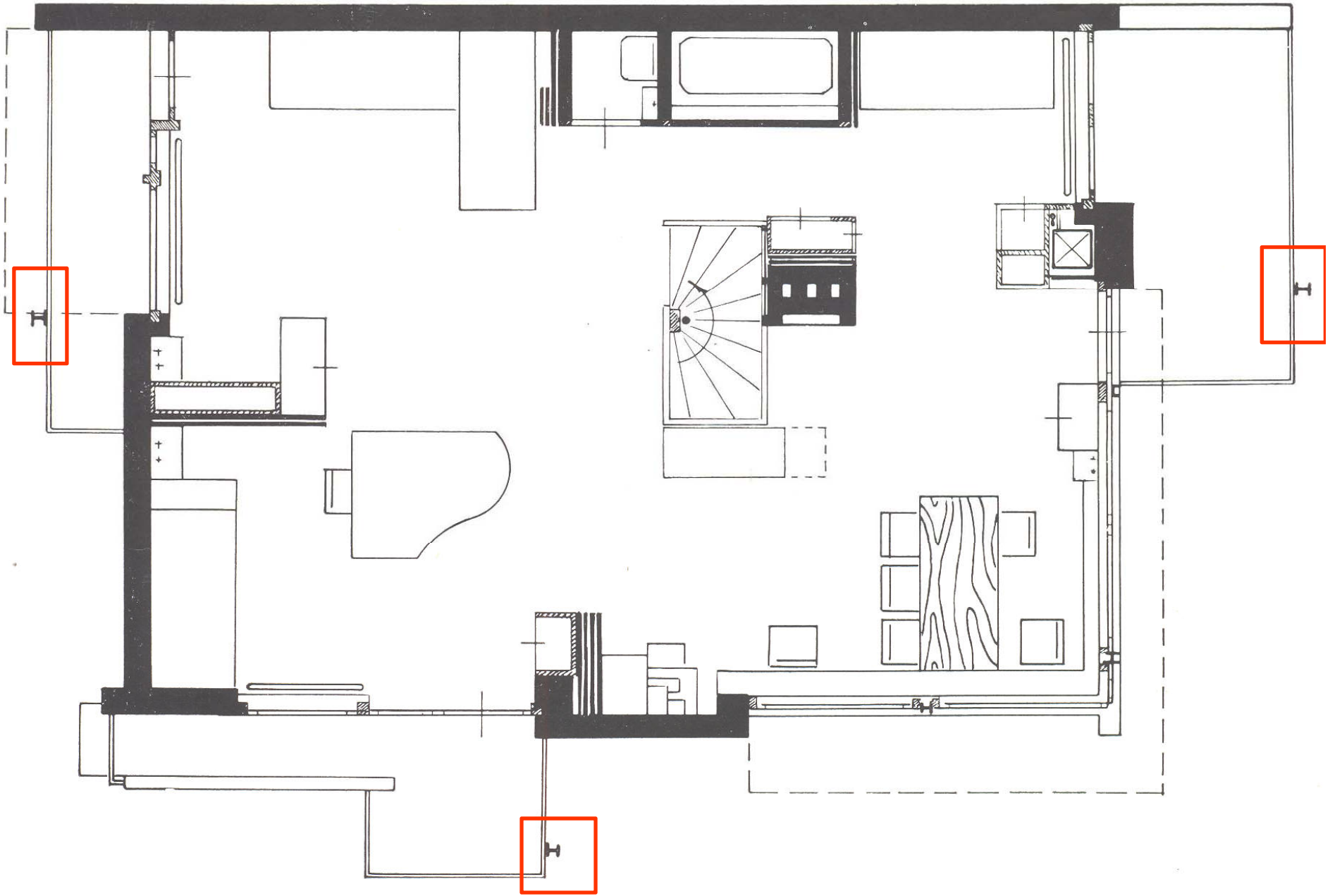

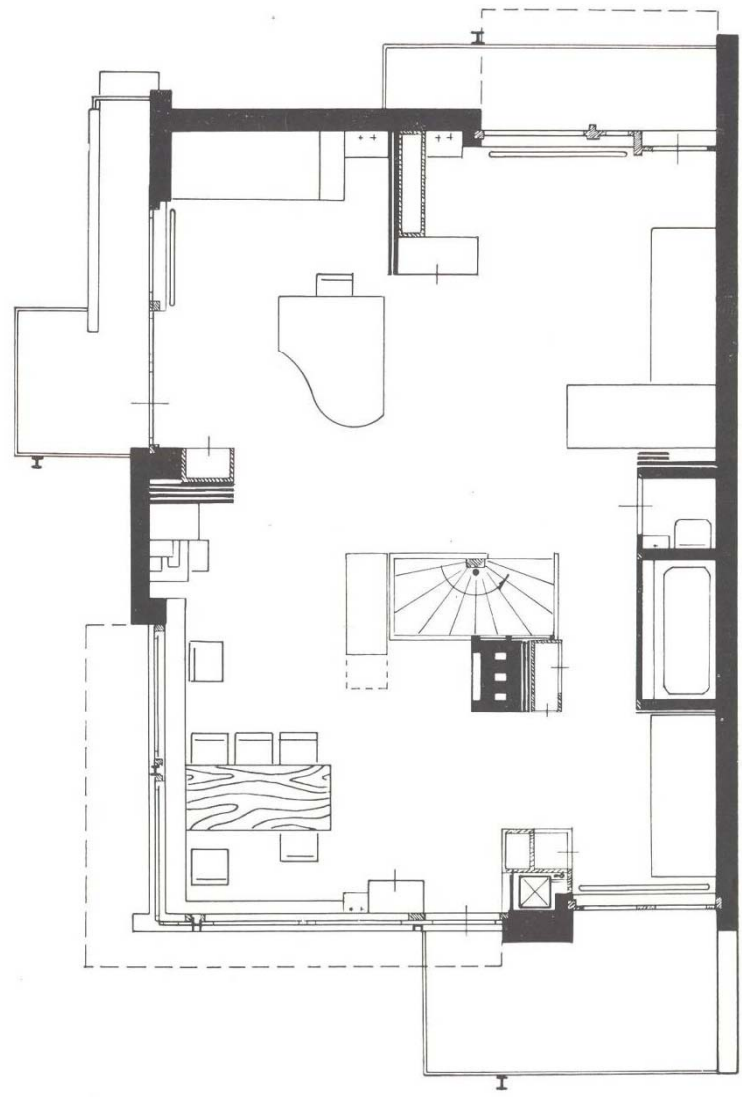
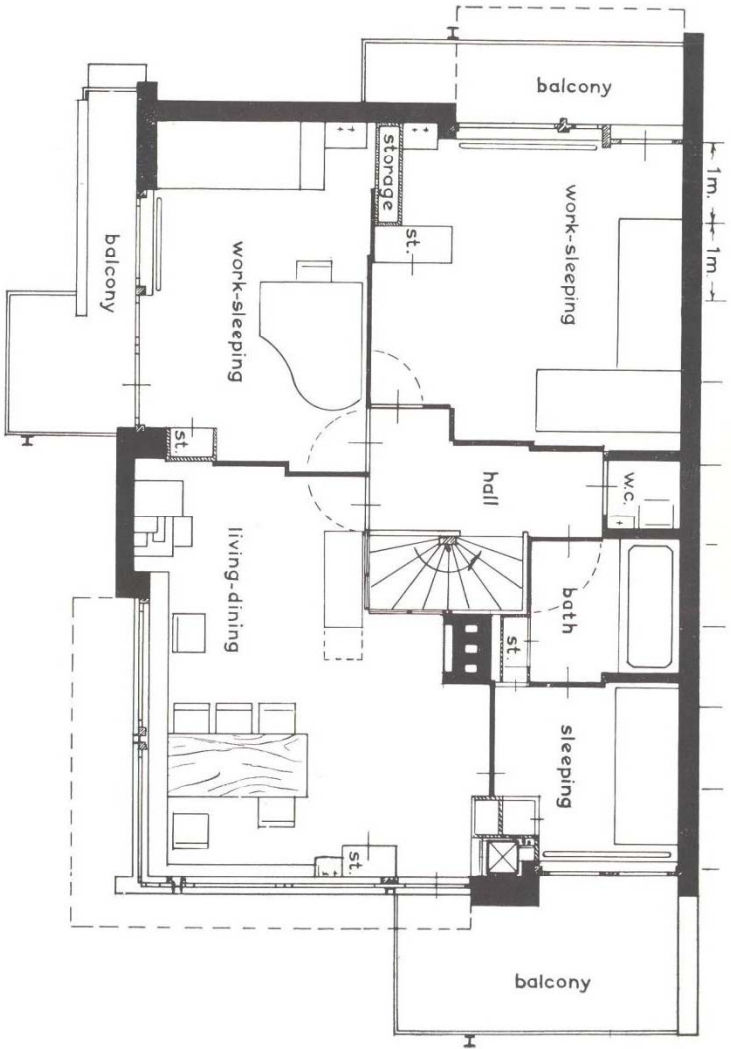





Red-blue chair, 1918/19.

# MEUBELMAKERIJ



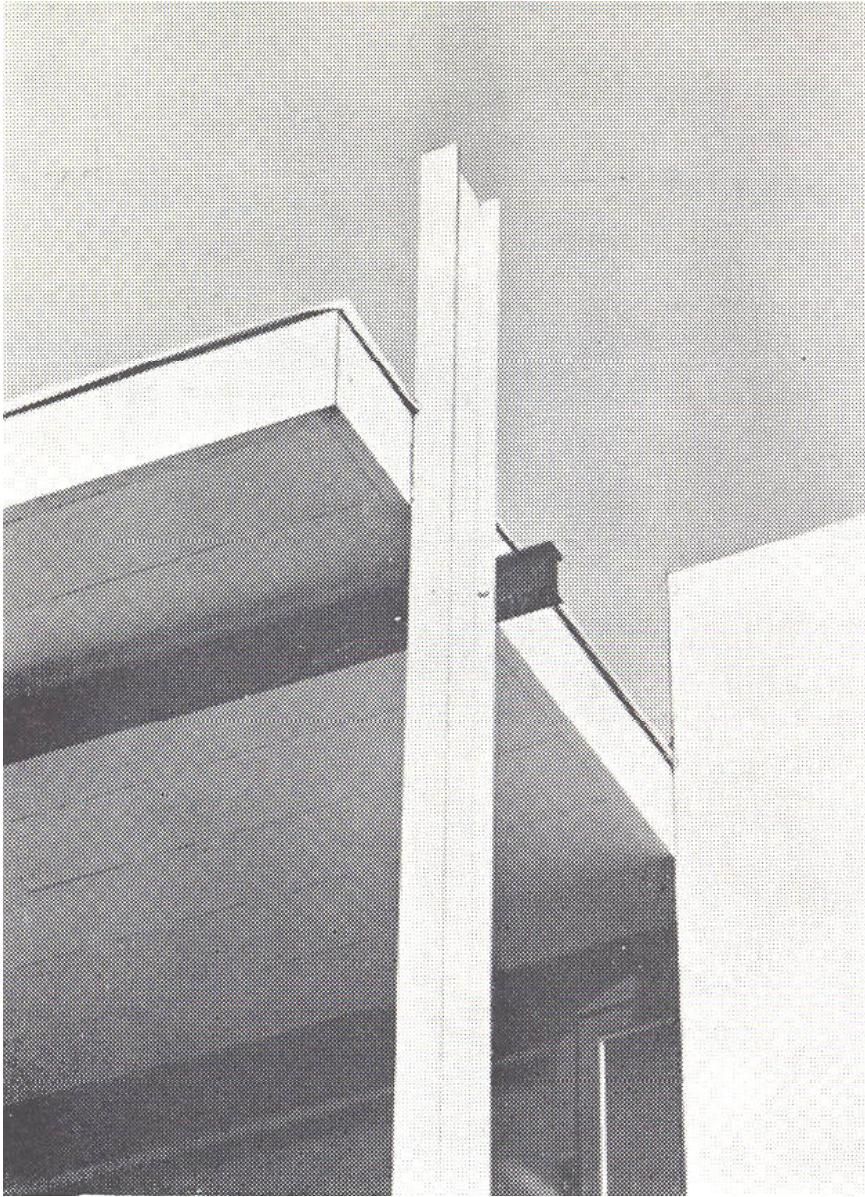

Gerit Rietveld: Schreder House 1924.-5.

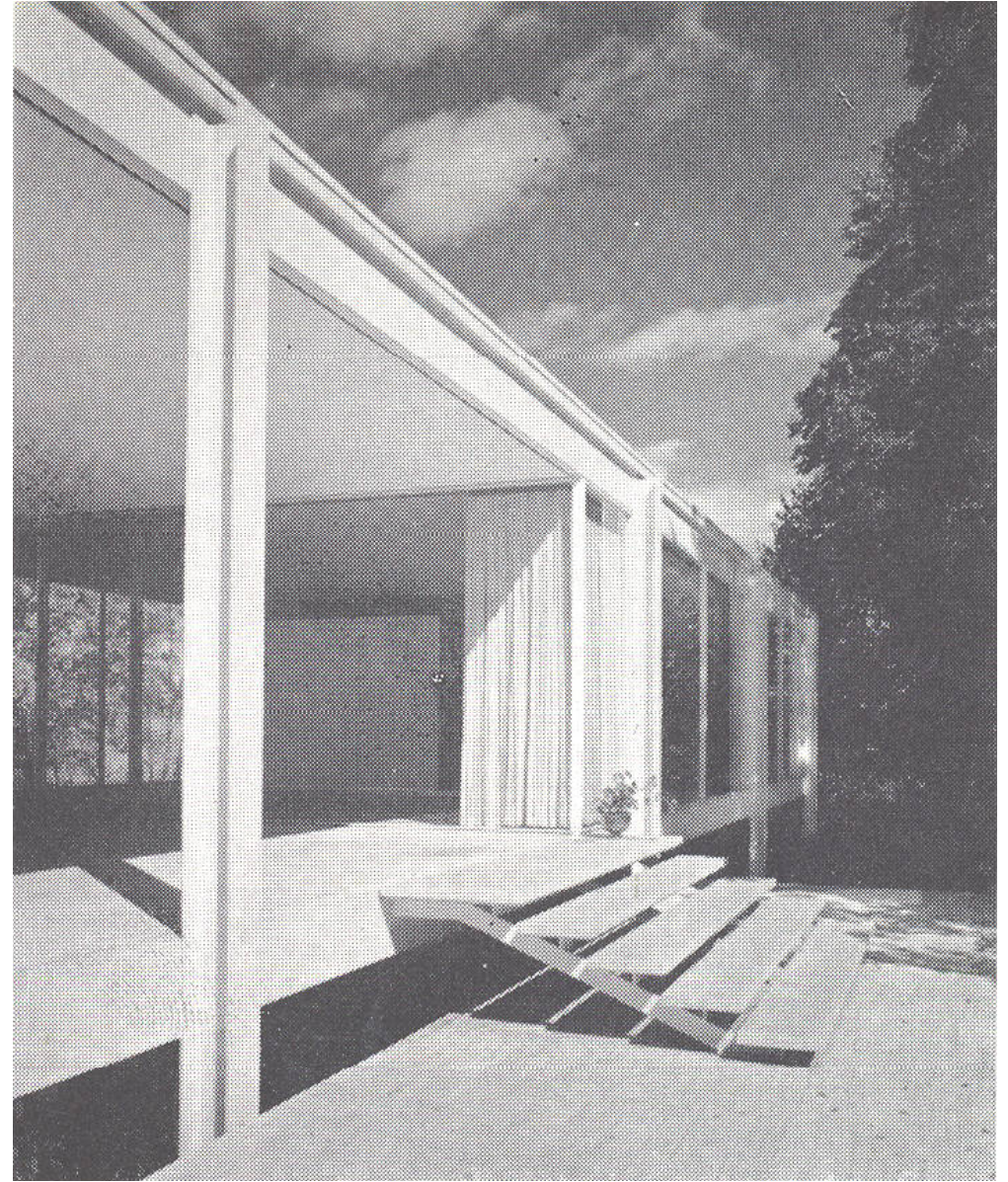

Mies van der Rohe: Farnsworth House 1945.-51.

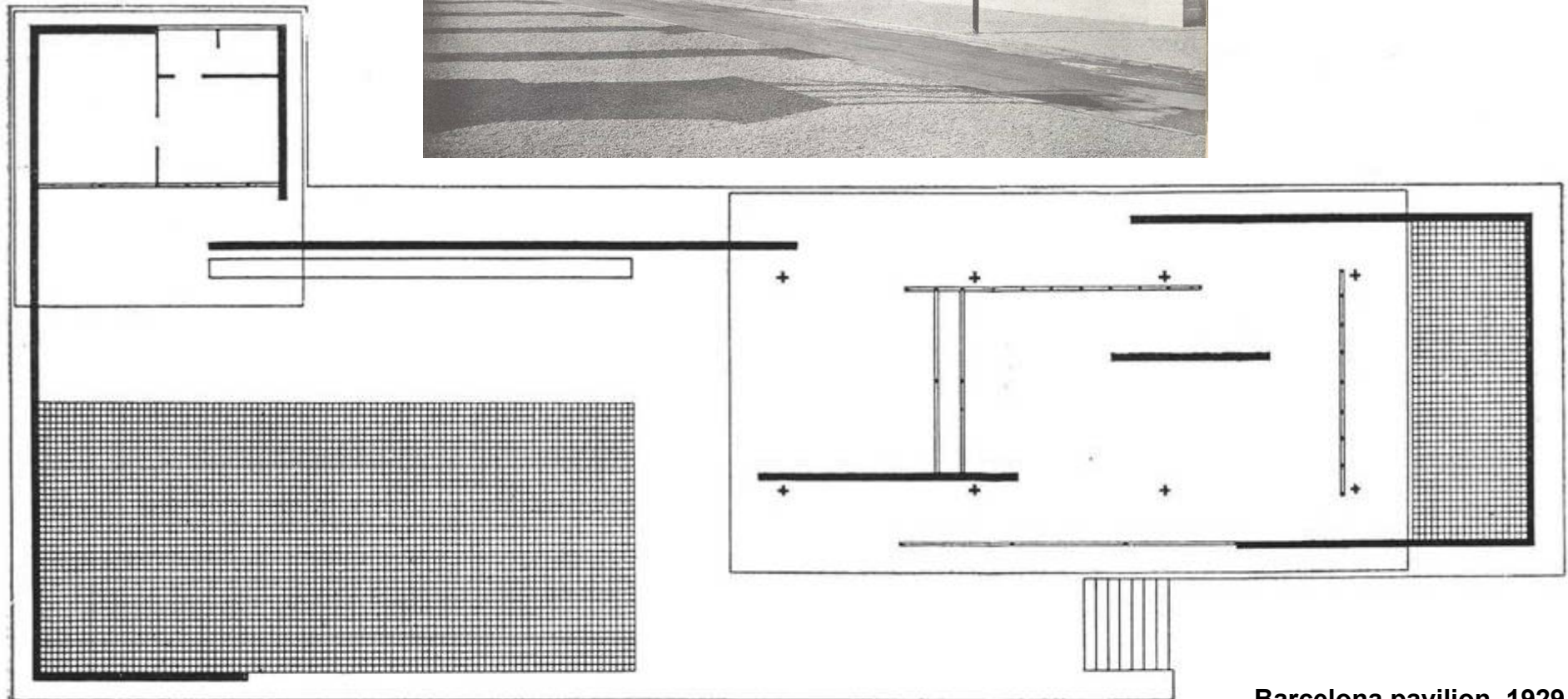

“LESS IS MORE”

“Gott ist im detail”

Barcelona pavilion, 1929.

Mies van der Rohe

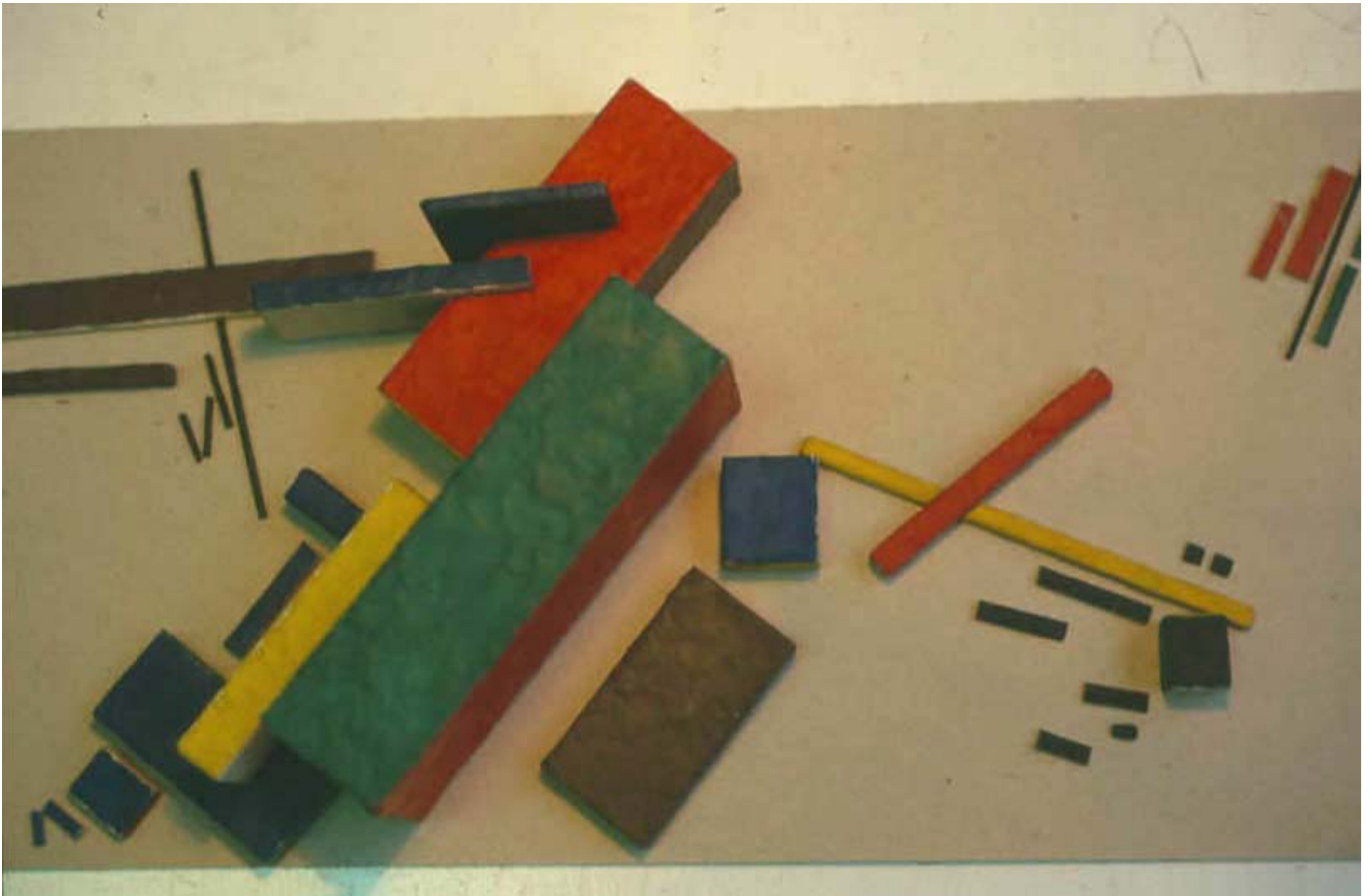

Kazimir Malevič: "kuća u izgradnji"

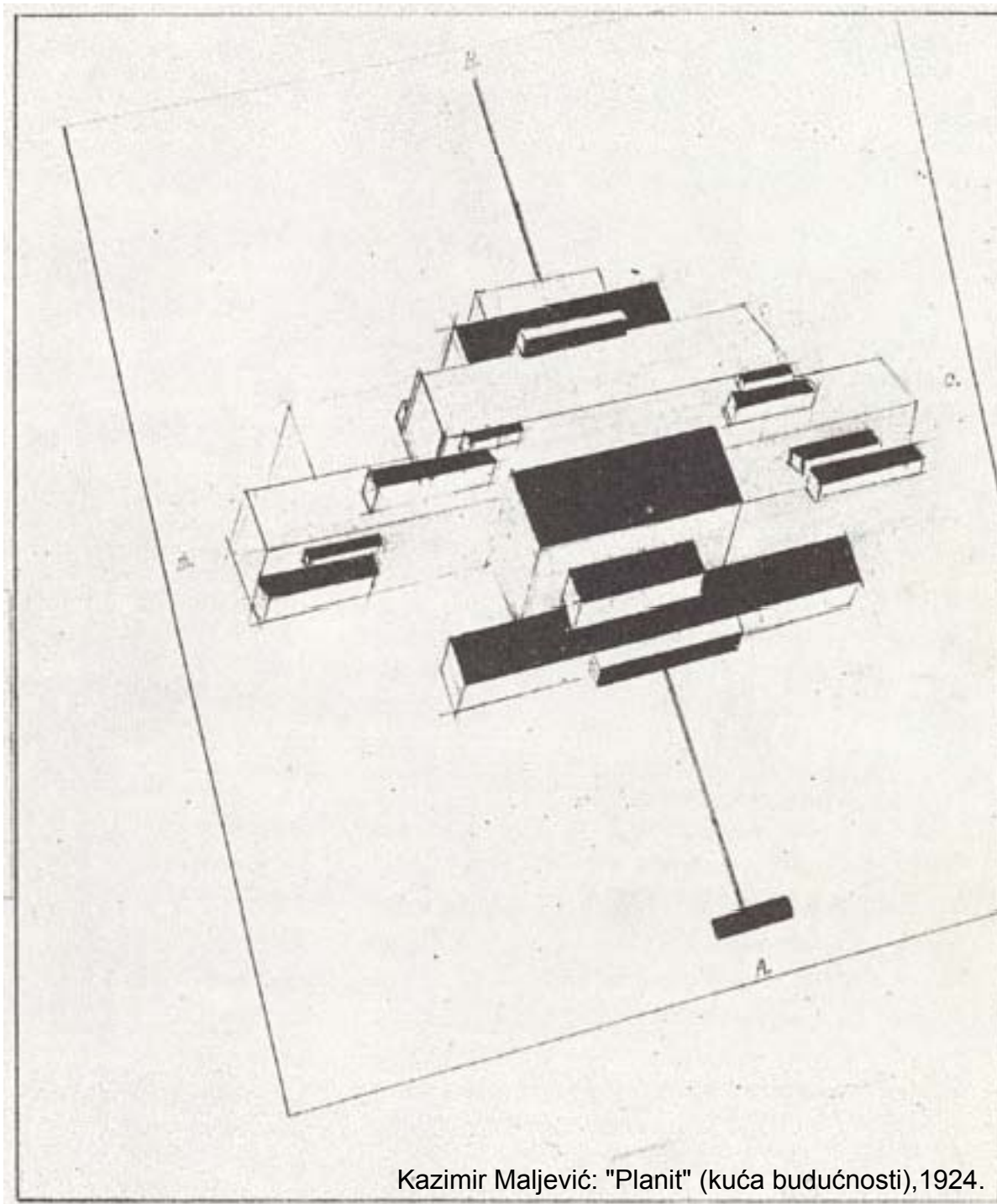

Kazimir Maljević: "Planit" (kuća budućnosti), 1924.

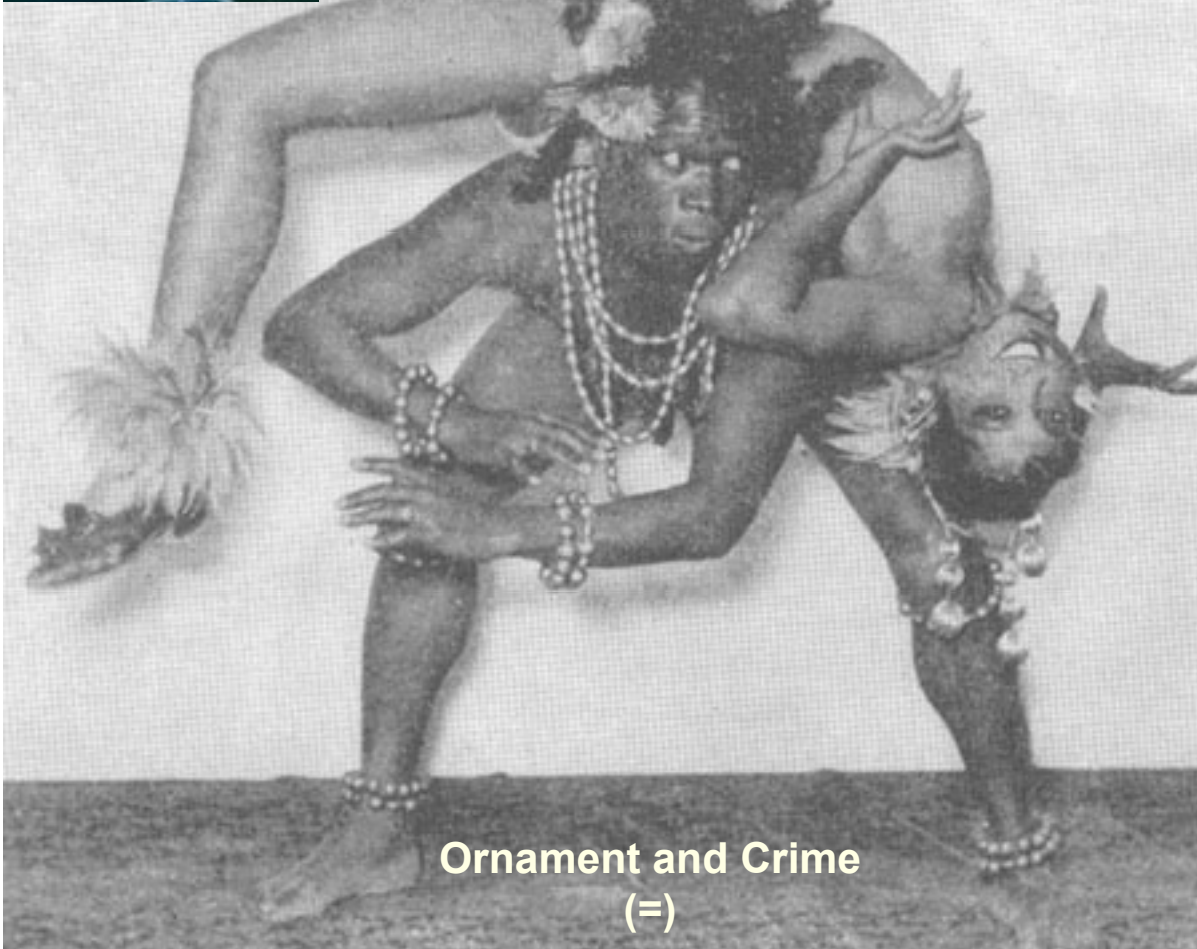

Ornament and Crime  
(=)



Adolf Loos

Adolf Loos

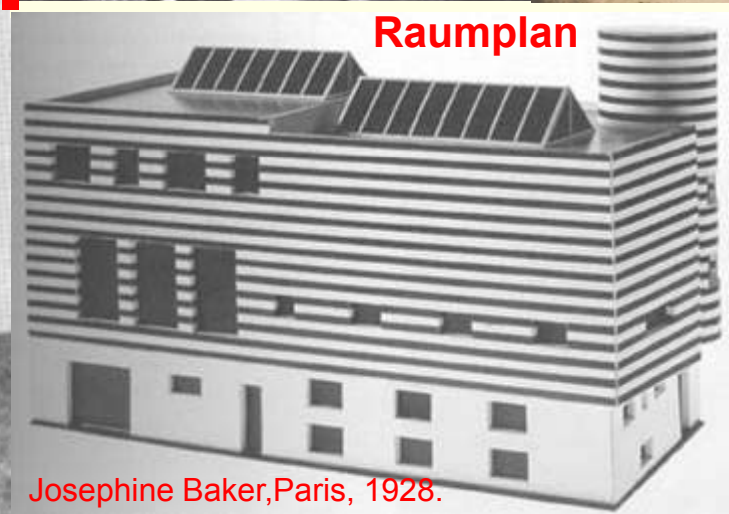

Raumplan

Josephine Baker, Paris, 1928.

Paul Engelmann and the philosopher Ludwig Wittgenstein (1889- 1951) designed and built this villa from 1926 to 1928 for Margarethe Stonborough-Wittgenstein, the philosopher's sister.



Ludwig Wittgenstein: Vila Wittgenstein, Wien

# OBLIK

jednostavnost, elementarni volumen  
(simetrija) "mir"

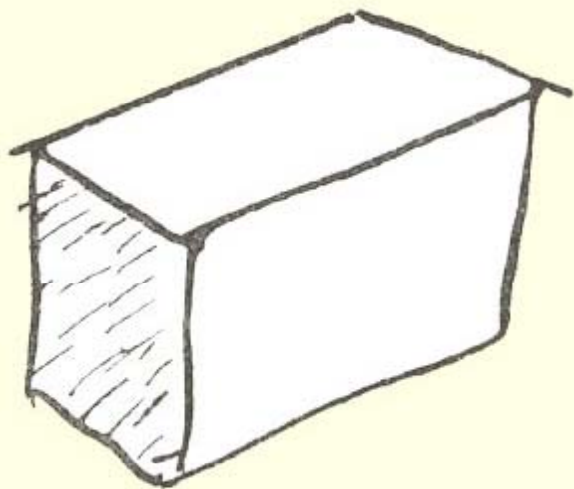

SEC's house = Simple, Elegant, Concise house

složenost, "slučajnost"  
puno malih volumena

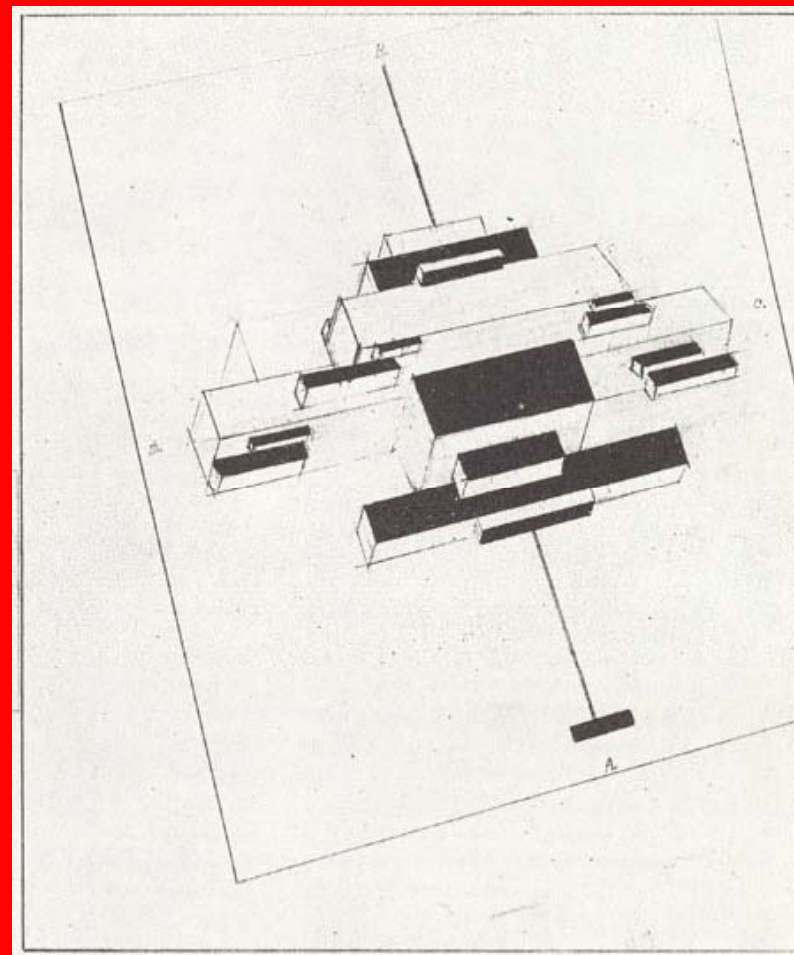

# "prisme pour"

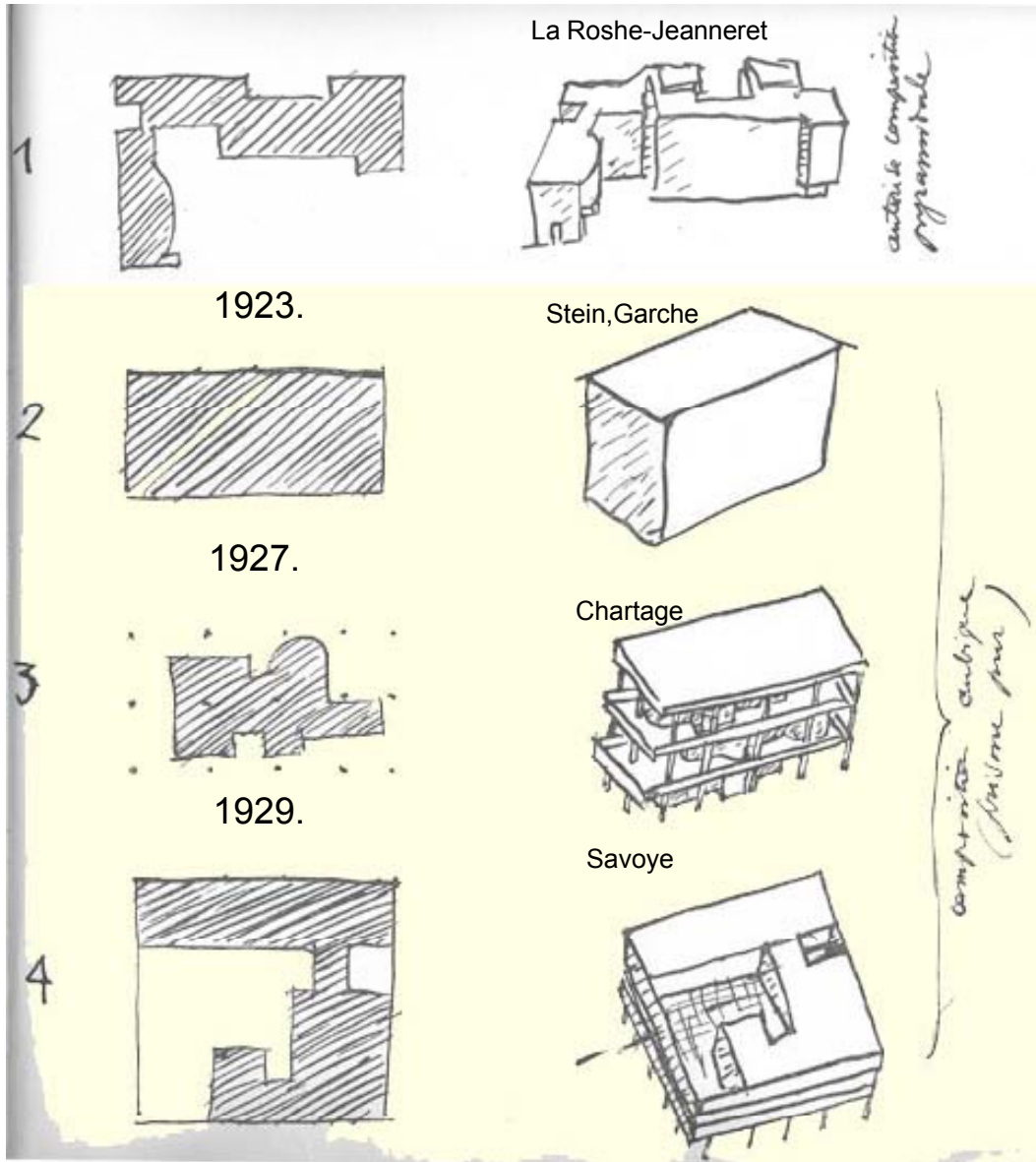

Charles Edouard Jeanneret = Le Corbusier

1931.

(objavljeno 1935.)

/+nećak Pierre Jeanneret ! /

Bazille depicted a gathering of like-minded friends in the studio he shared with [Pierre-Auguste Renoir](#). At the left, seated on a table, Renoir looks up to talk to Zola, who is on the stairs. In the center, Bazille shows [Edouard Manet](#) one of his recent works, while Monet stands behind him. Bazille's close friend Edmond Maitre plays the piano at the right.

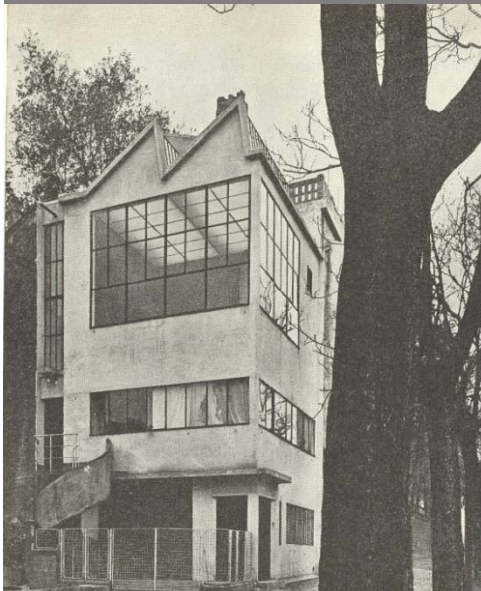

Le Corbusier: Maison Ozefant, Paris, 1922

Le Corbusier: Vocreason ,1922.

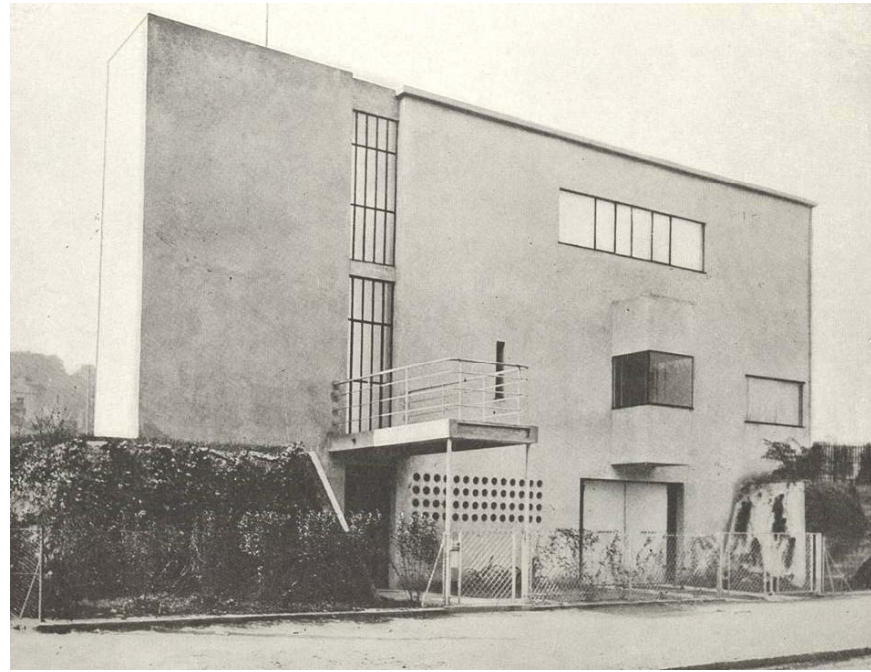

Le Corbusier: Vocreason ,2002.



Henry Russell Hitchcock & Philip Johnson:



MOMA izložba i knjiga

A first principle: **ARCHITECTURE AS VOLUME**  
A second principle: **CONCERNING REGULARITY**  
A third principle: **THE AVOIDANCE OF APPLIED DECORATION**

1932.

“Schinkelpavilion”



**Karl Friedrich Schinkel:**

(rezidencijalni pavilion) Charlottenburg, Berlin, 1825. |

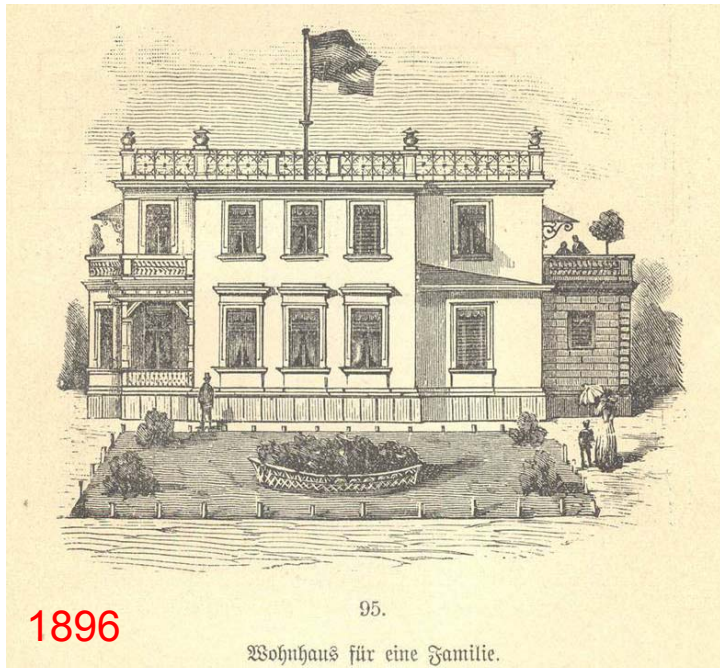
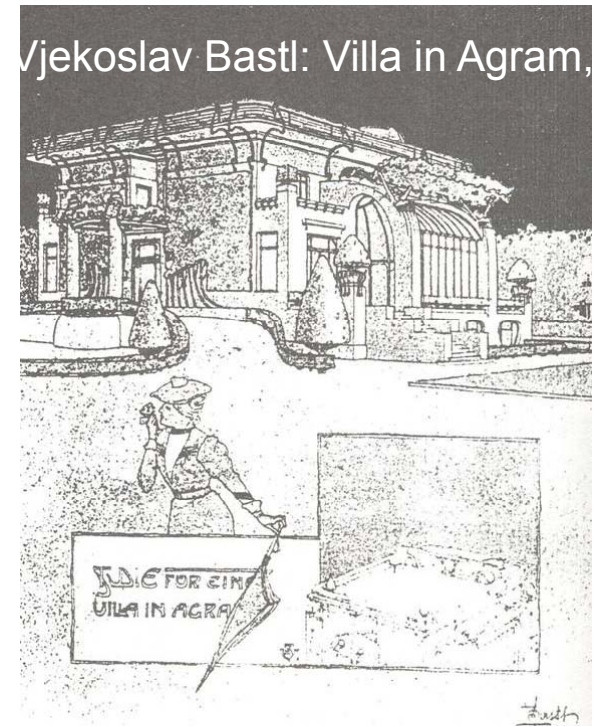

François Hennebique (1842-1921)

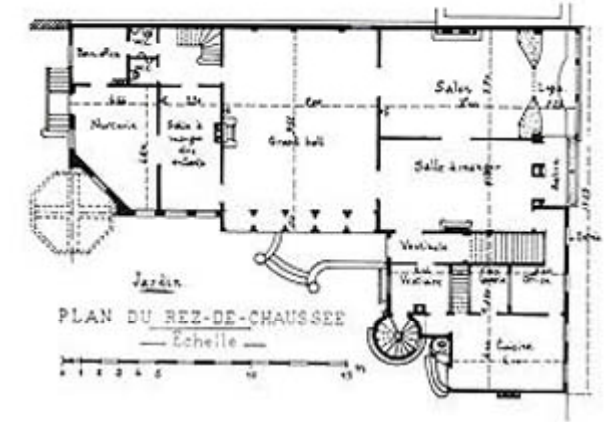
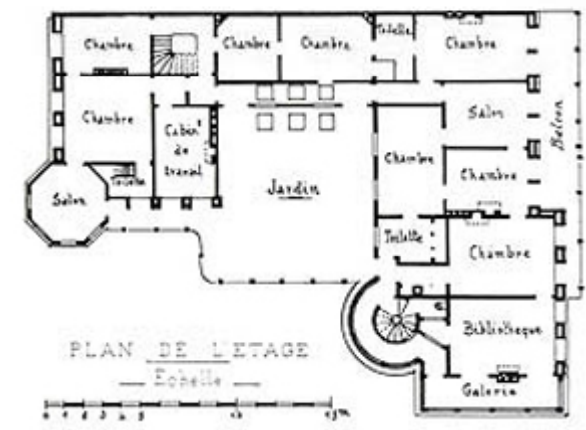
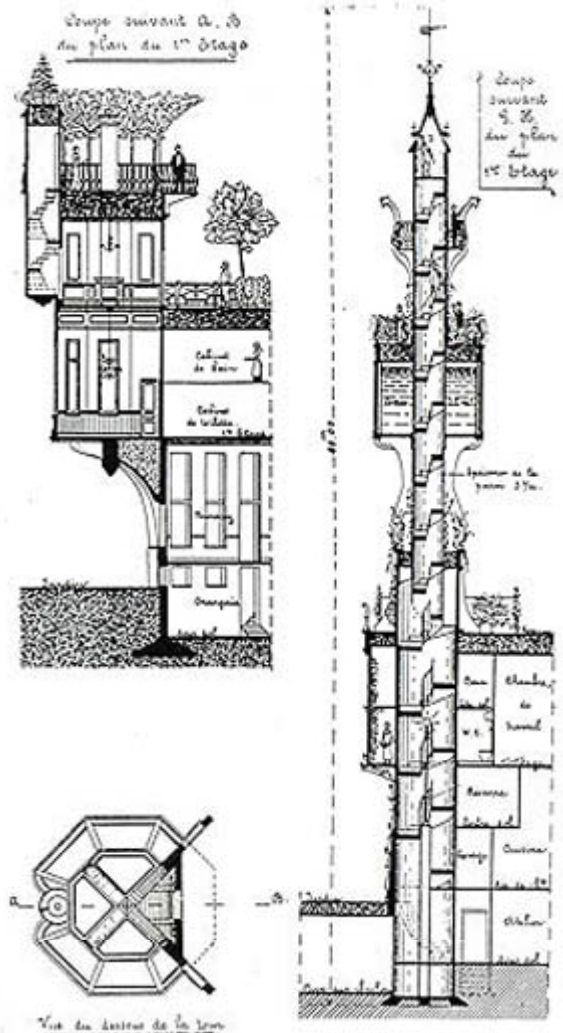
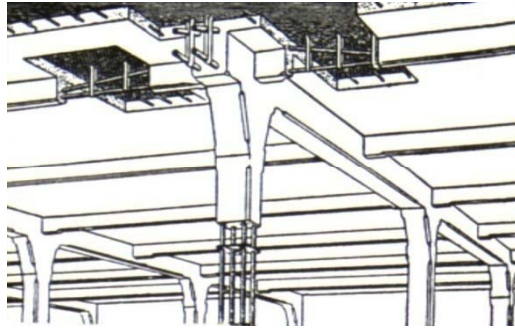

**Maison Hennebique** ,1901-1903  
**adresse : 1, avenue du Lycée Lakanal,  
Bourg-la-Reine, France**

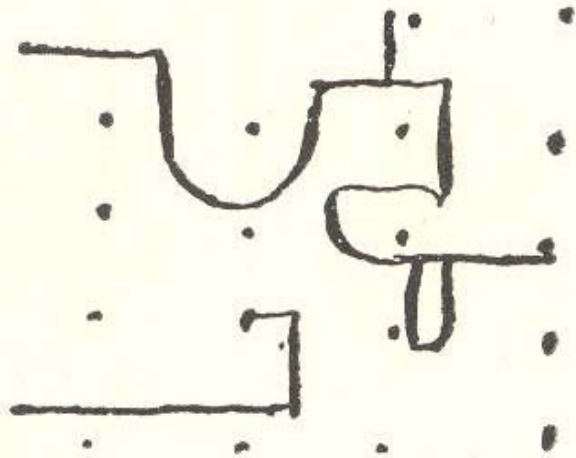

**1.**  
nosivi skeletni sistem  
i slobodna postava  
pregradnih zidova

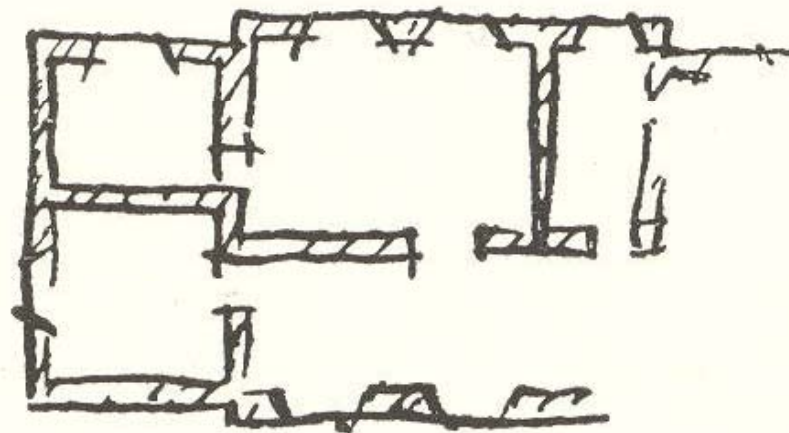

**2.**  
krovne terase i vrtovi

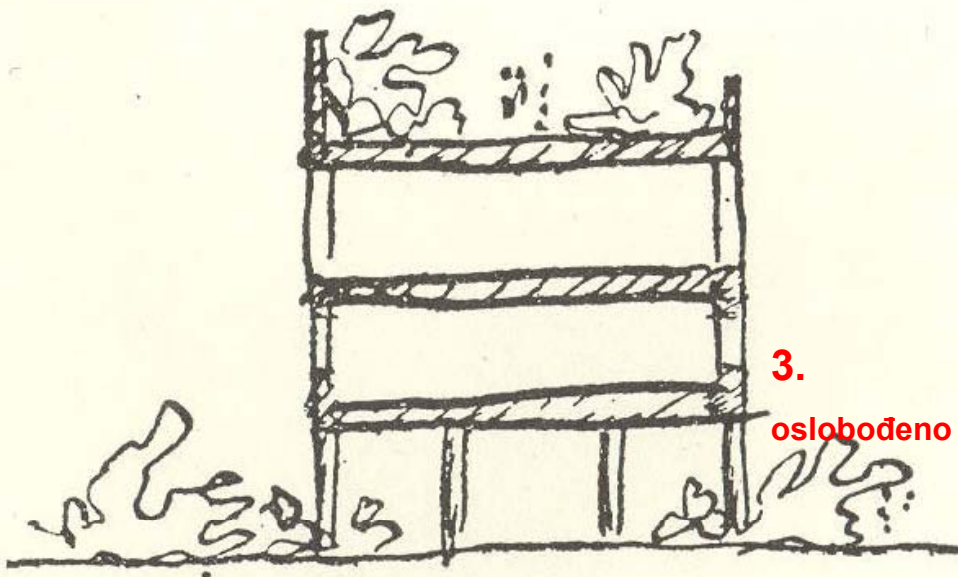

**3.**  
oslobođeno prizemlje

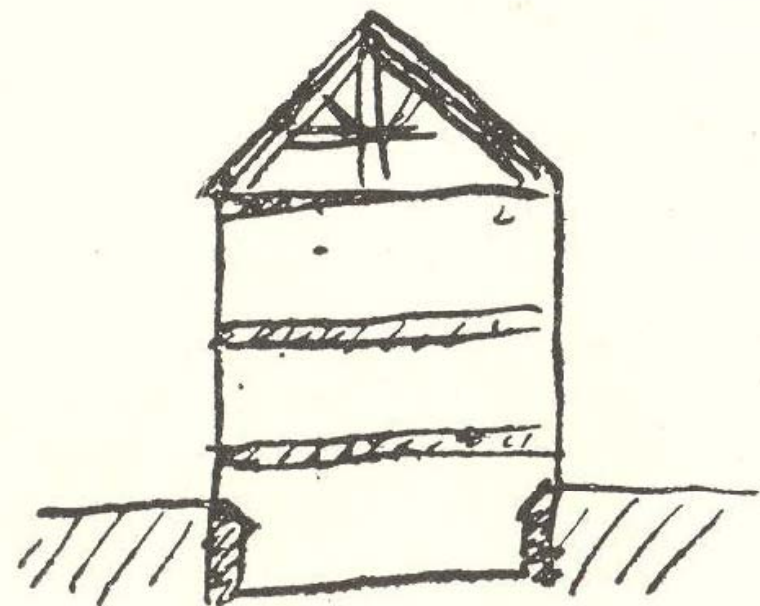

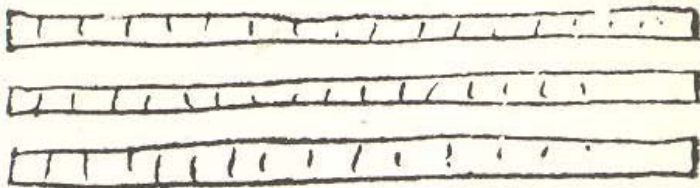

5.  
trakasti prozori

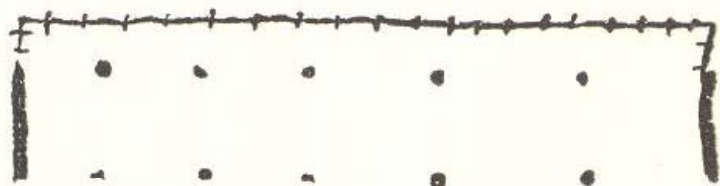
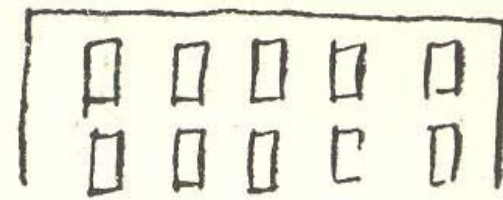

4.  
nenosivo pročelje

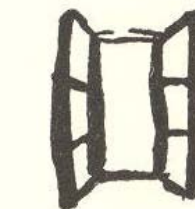
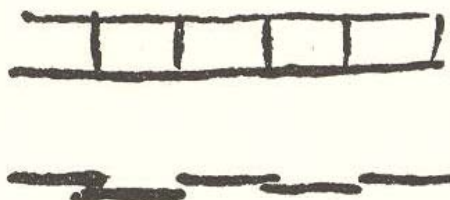
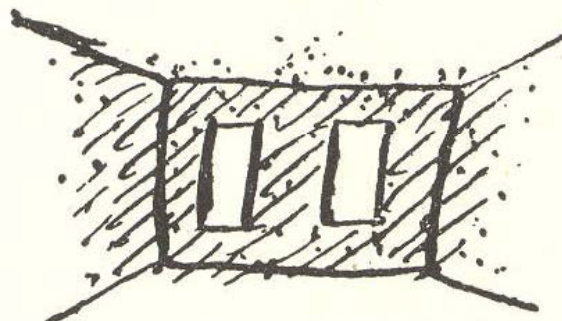
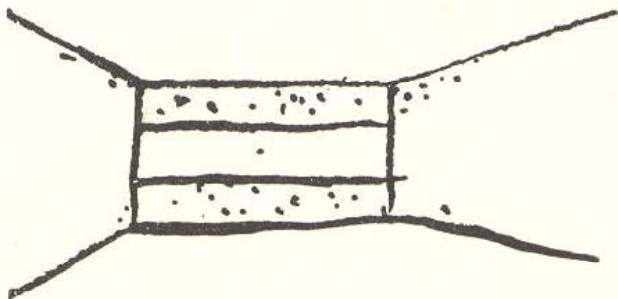
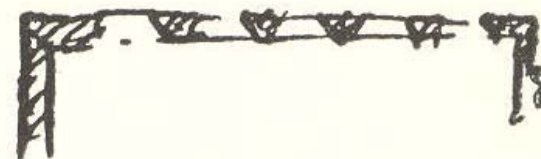

Le Corbusier: "5 points de l'architecture moderne"

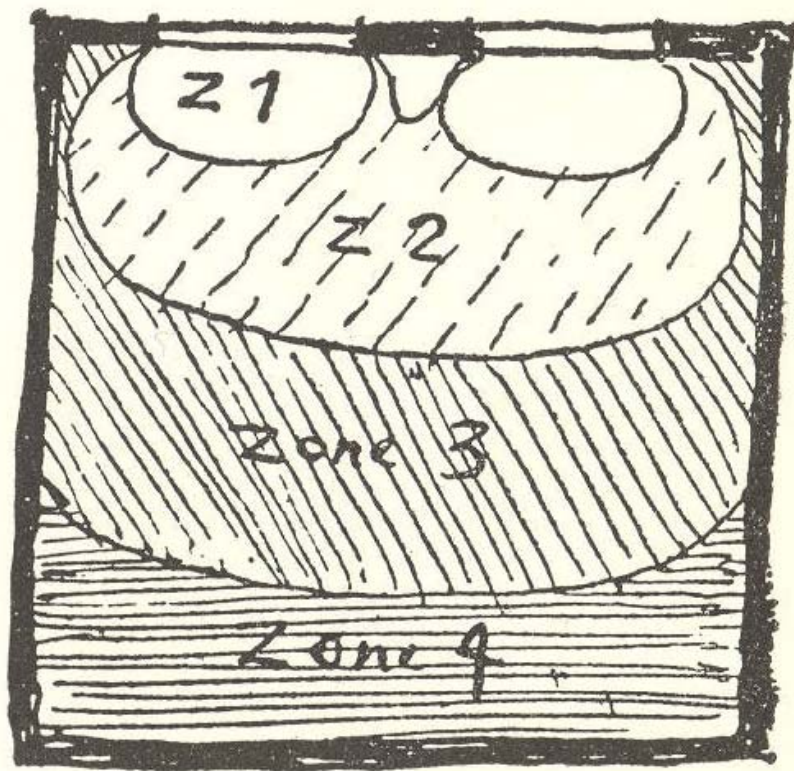
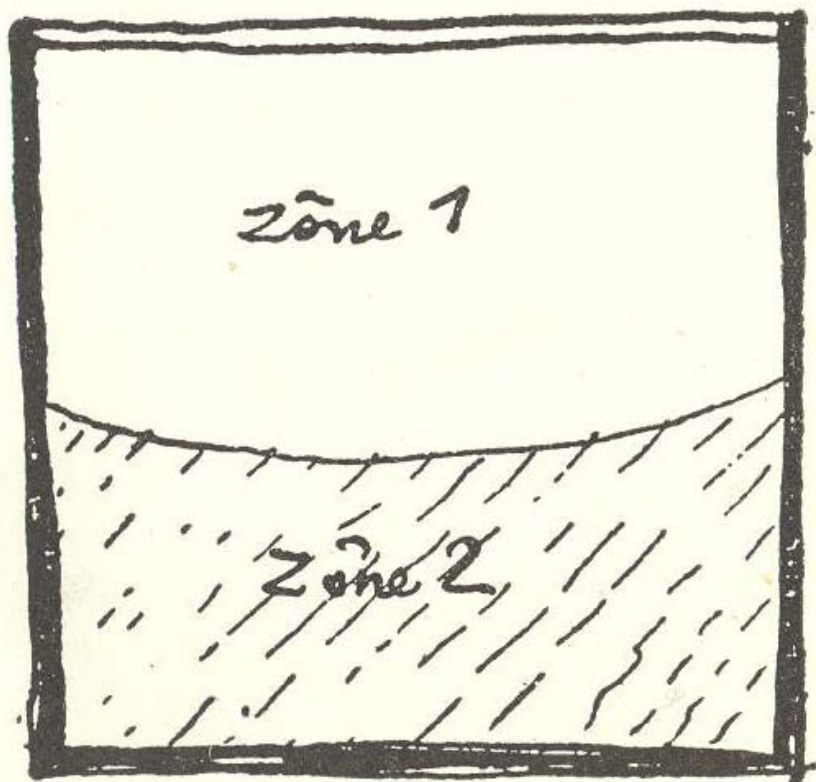
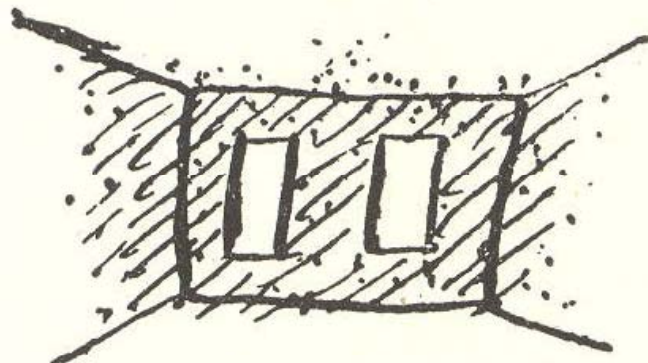
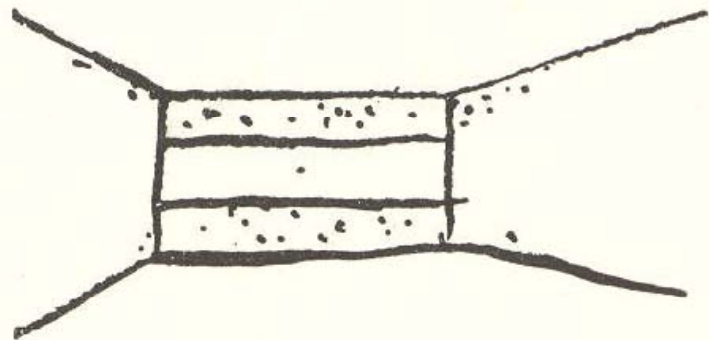

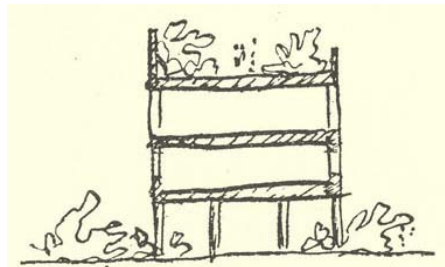

SUN TERRACE at the house in New York, 1930te

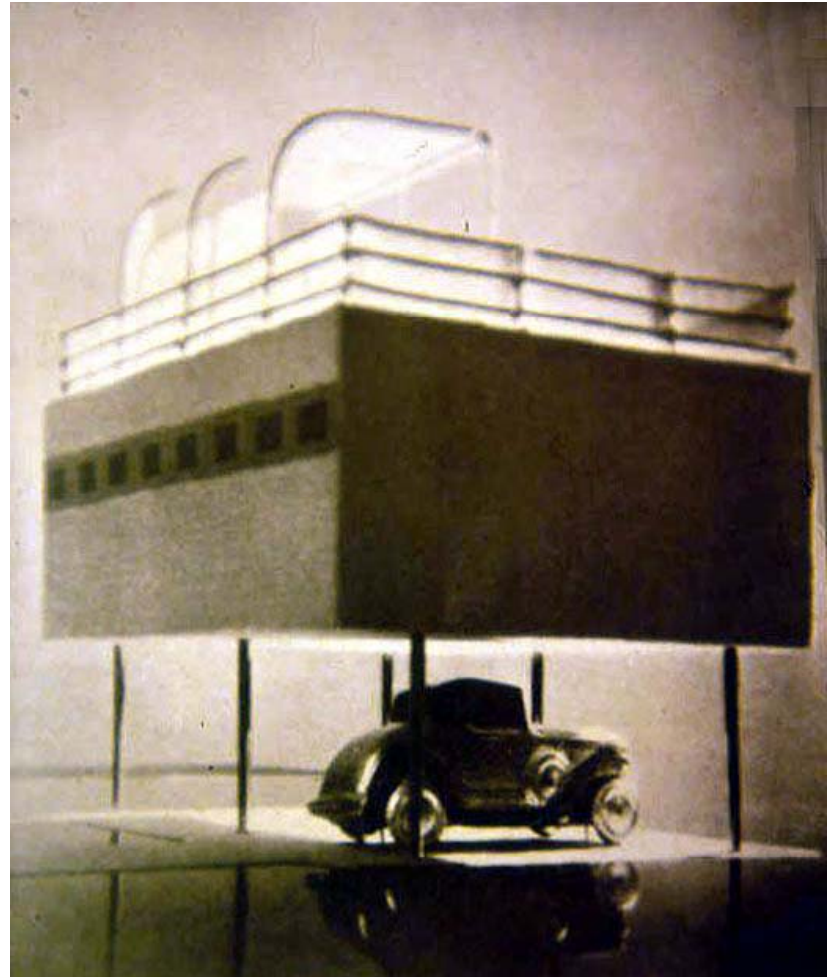
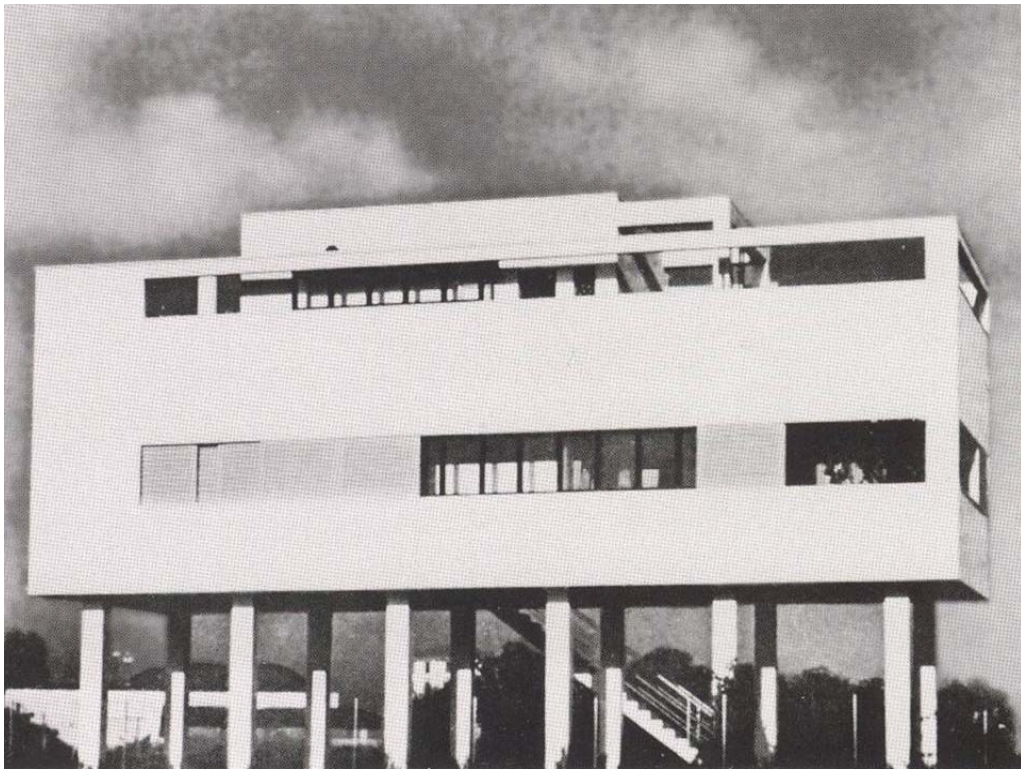
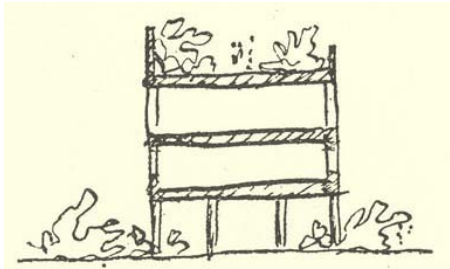

Luigi Fagnini: Vila Figini, Milan, 1935



1927 - Villa Stein, Garches, near Paris



**The Steins**  
apolinijevska situacija



**The Steins**  
dionizijevski trenutci

# The Death of Modern Architecture



July 15, 1972 at 3.32 p.m.



# THE LANGUAGE OF POST-MODERN ARCHITECTURE

1977.

CHARLES JENCKS

FORM FOLLOWS FUNCTION



Peter Blake (1920-2006)

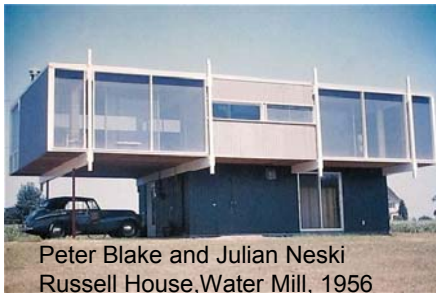

Peter Blake and Julian Neski  
Russell House, Water Mill, 1956

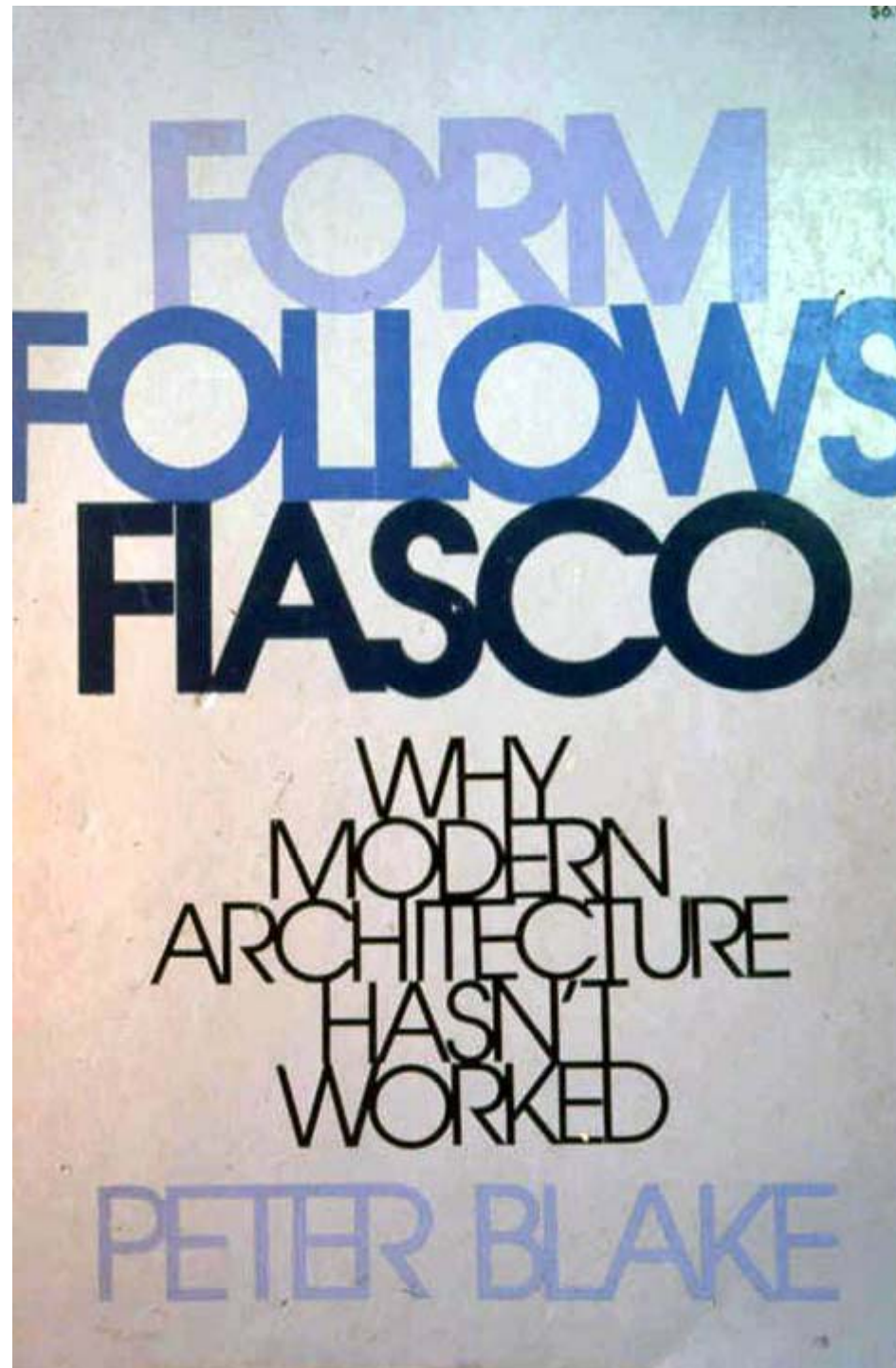

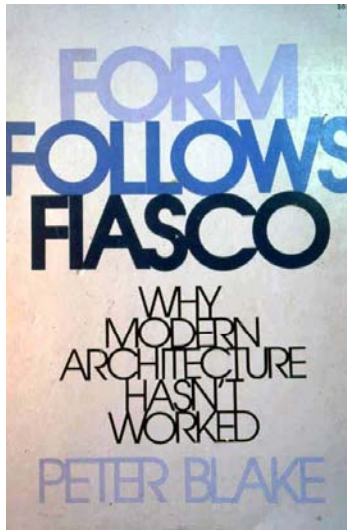

FORM FOLLOWS FINANCE

FORM FOLLOWS FORM

FORM FOLLOWS FANTASY

FORM FOLLOWS FREEDOM

FORM FOLLOWS FASCINATION

Form Follows Fiction (tradition, history)

Form Follows Function (construction)

Form Follows Future = energy, material

**FORMA SLIJEDI KONSTRUKCIJU I MATERIJAL**

post-moderna



Quinlan Terry:Rezidencija u Londonu,1990-te

1

The Museum of Modern Art Papers on Architecture

Published by The Museum of Modern Art, New York in association with  
The Graham Foundation for Advanced Studies in The Fine Arts, Chicago

# Complexity and Contradiction in Architecture

1966.

Robert Venturi

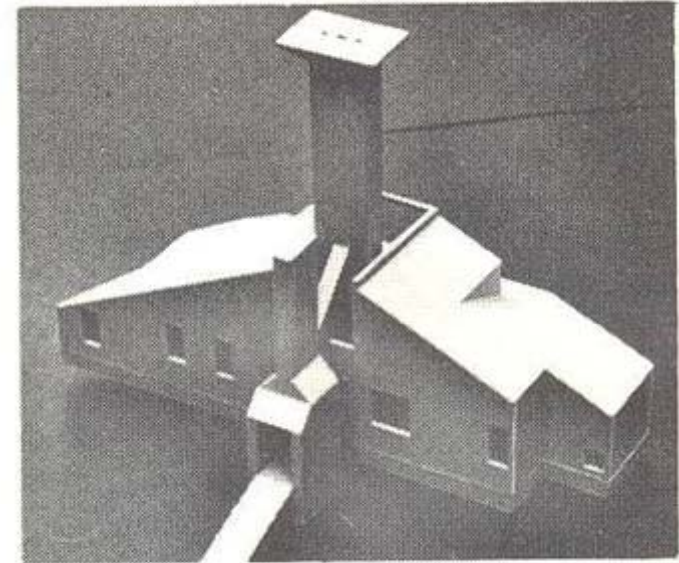

270

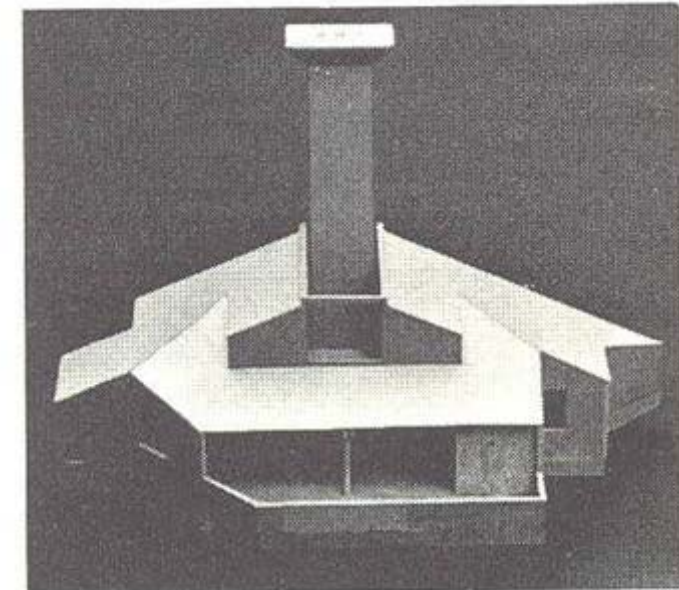

271

Beach House, 1959.

Kompleksnosti i kontradikcije:

- \*kompleksna i jednostavna
- \*otvorena i zatvorena
- \*velika i mala
- \*tipična i posebna
- \*simetrična i asimetrična
- \*trakasti prozori i rupa u zidu



luk : greda

Robert Venturi :Vanna Venturi House, Chesnut Hill, 1962.



# LEARNING FROM LAS VEGAS

Revised Edition

Robert Venturi Denise Scott Brown Steven Izenour

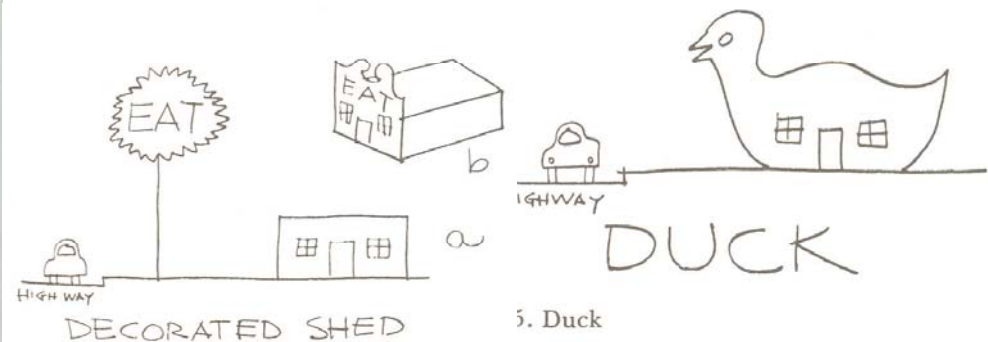
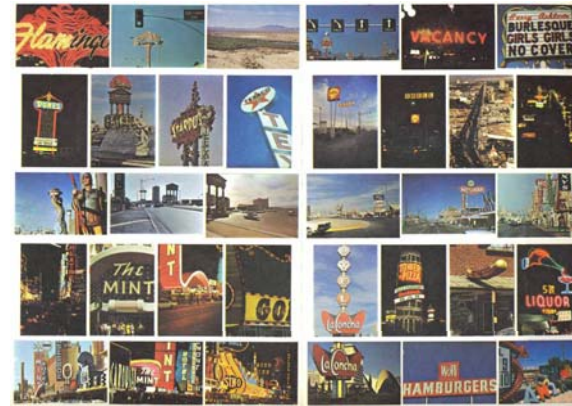

76. Decorated shed

5. Duck

Robert Venturi: "Learning from Las Vegas"

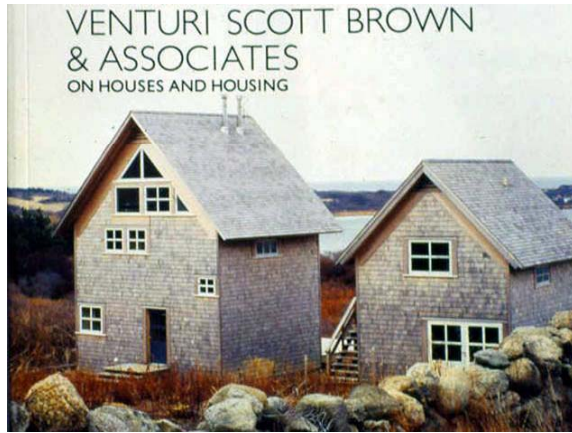



Robert Venturi: Own Home

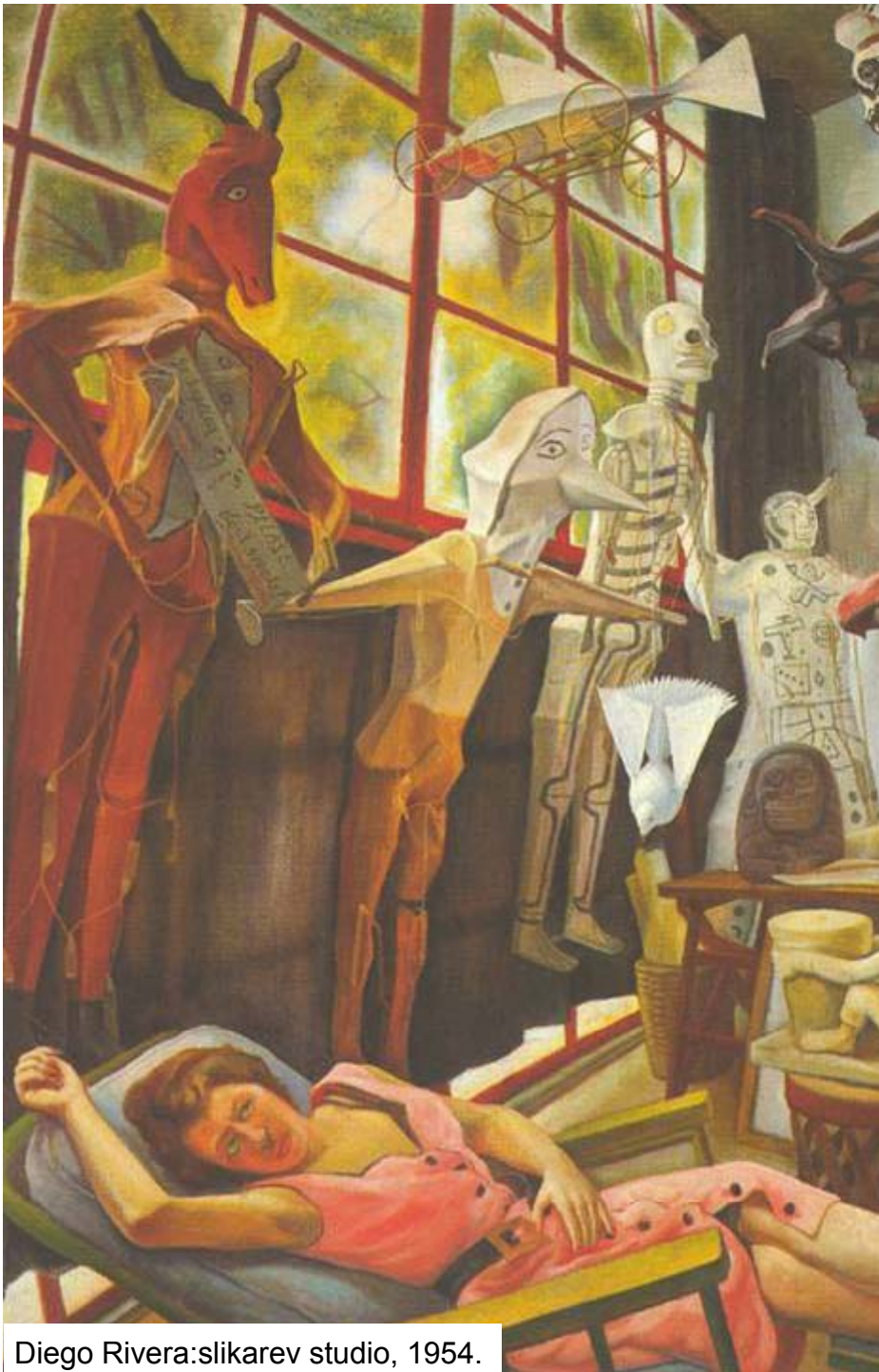

Diego Rivera:slikarev studio, 1954.



"less is bore"

Robert Venturi: arhitektov dom

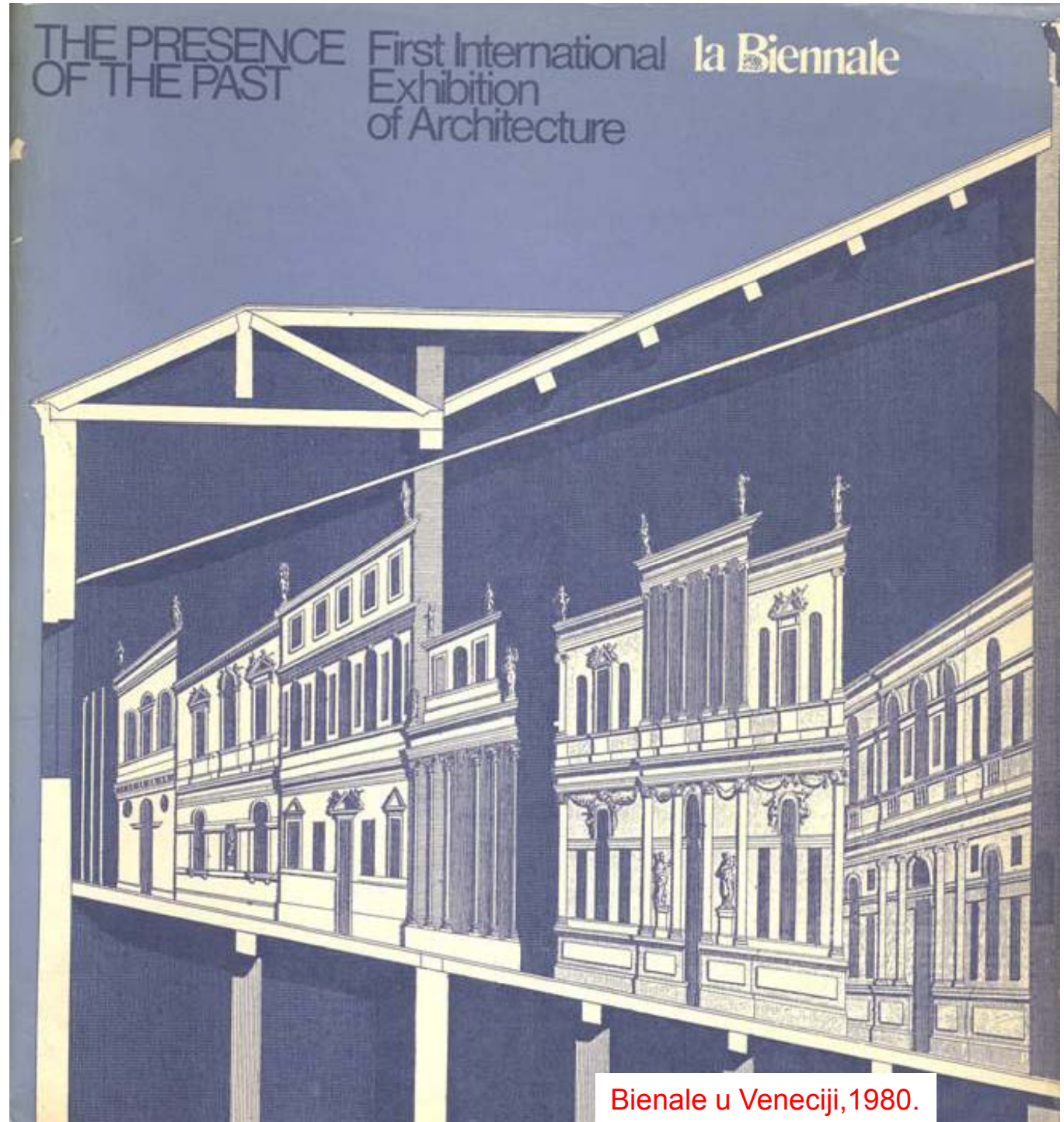
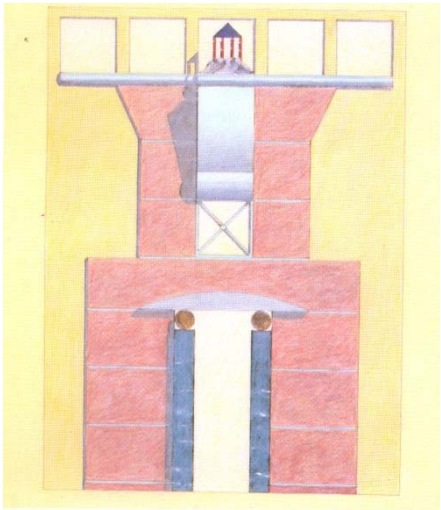
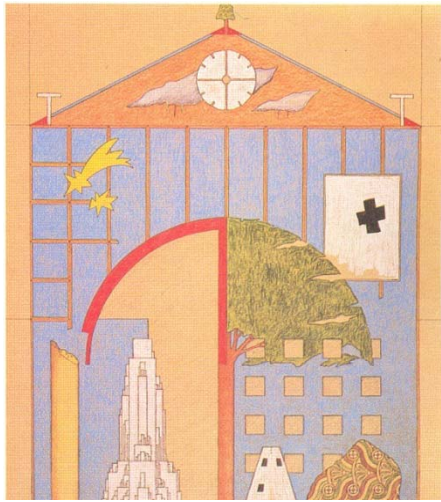

Bienale u Veneciji, 1980.

“arches, arches, arches,....”



Charles Jencks & Terry Farrell: Thematic House, London, 1979-85

“a greek temple- alike”

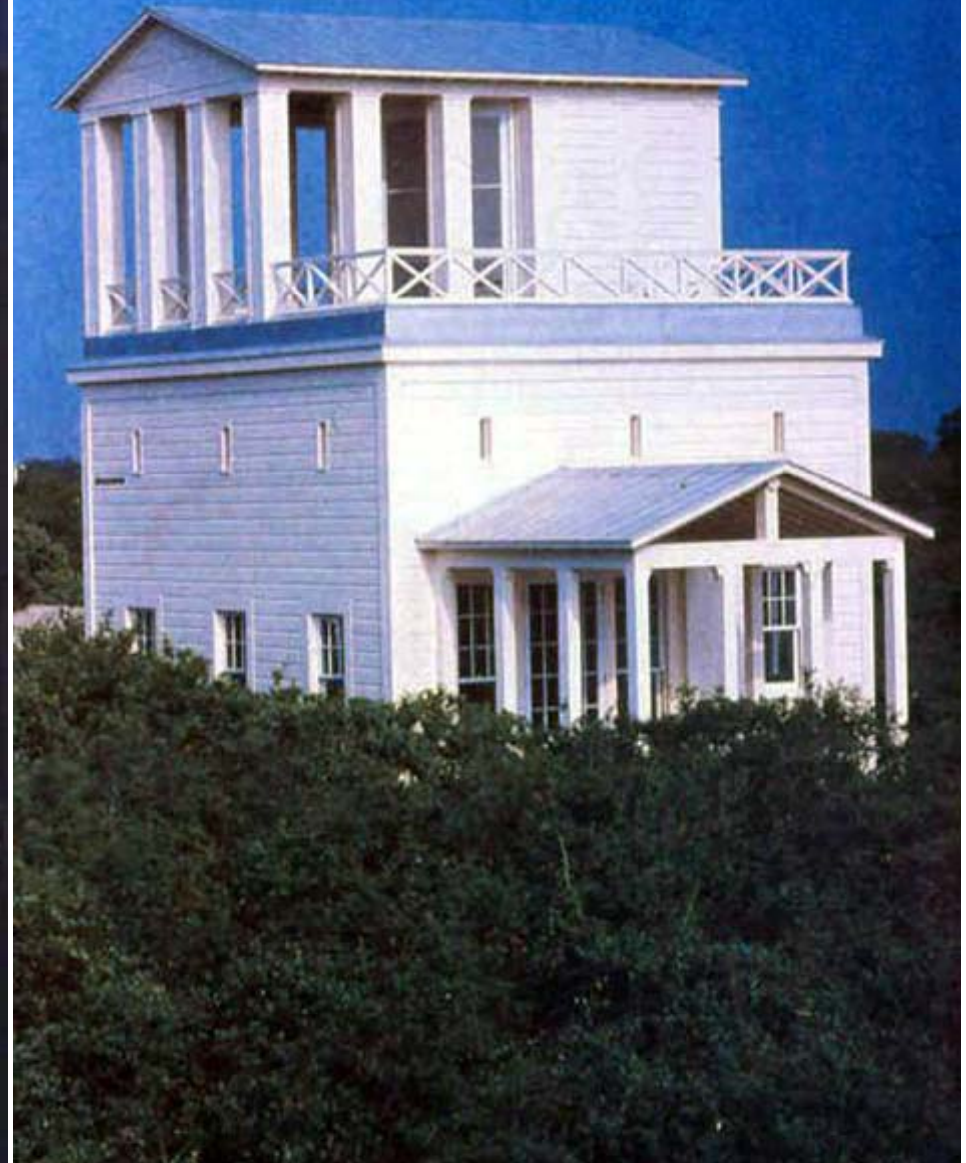

Leon Krier: "Modernism is not just a failure; it has been a huge mistake."

post-moderna

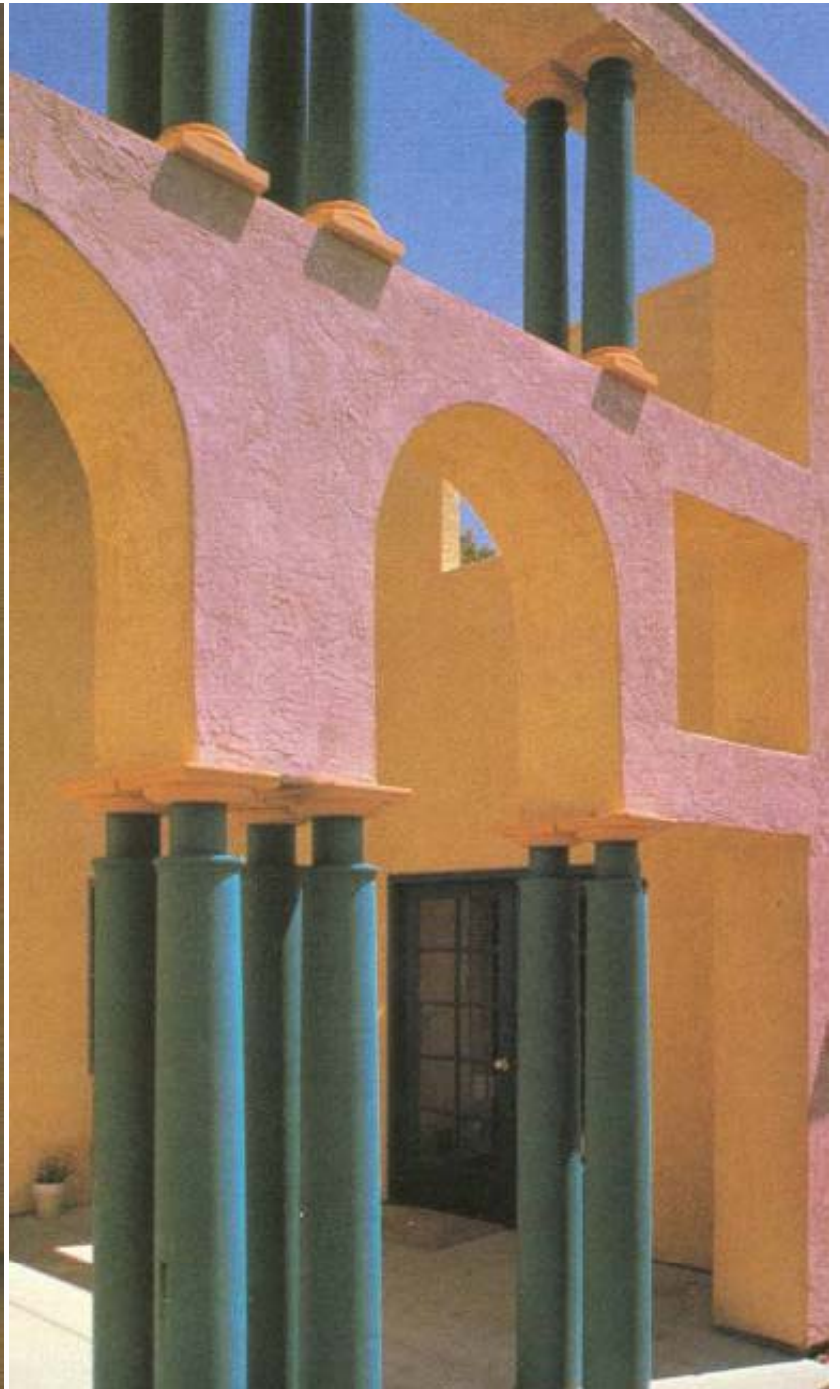
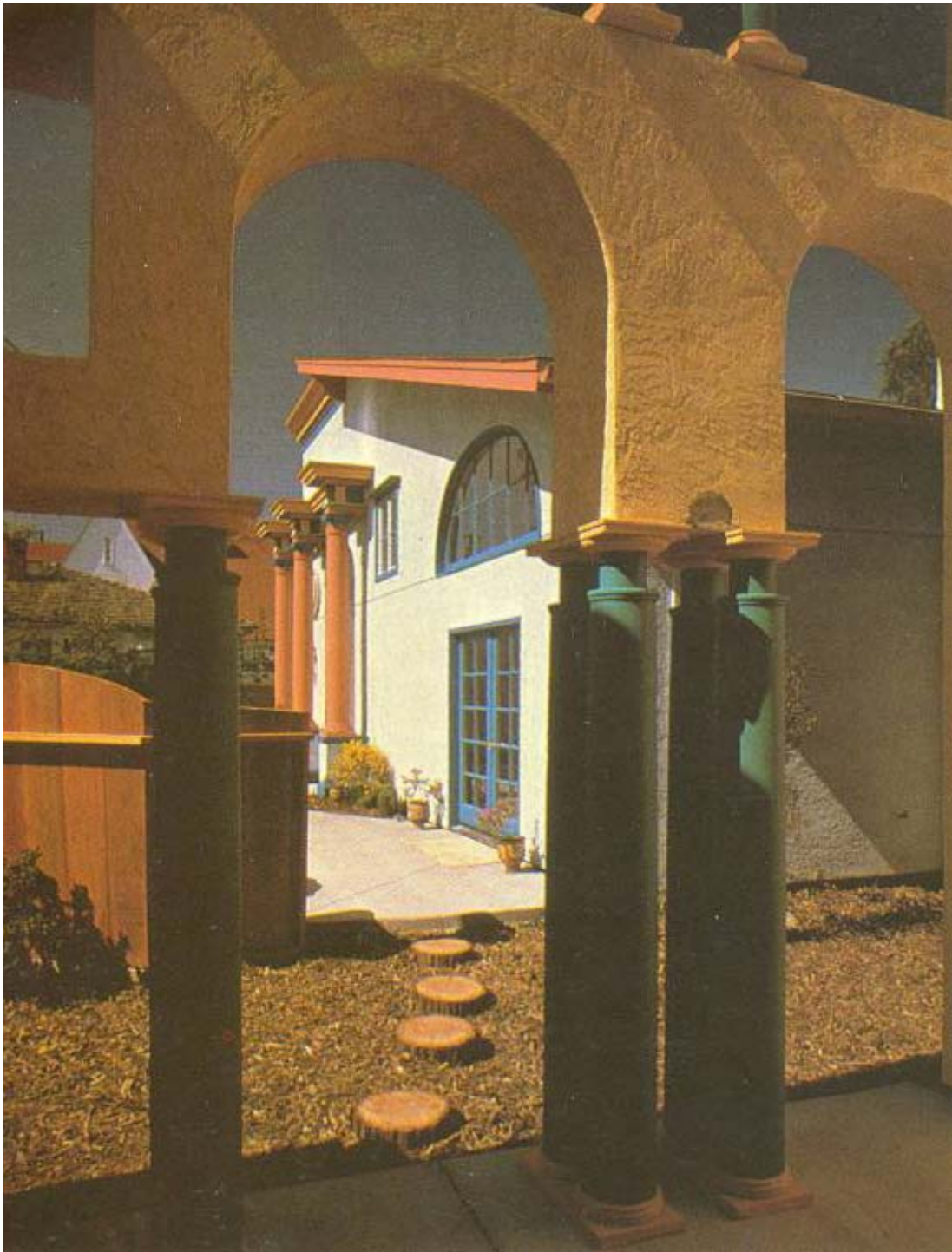

Thomas Gordon Smith: Tuscan House, California, 1979.



Č. Iveković: Trsteno, 1908.

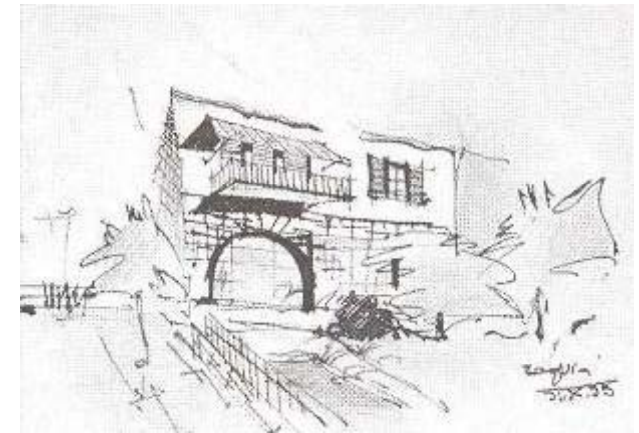

N. Šegvić: Trogir, 1965.

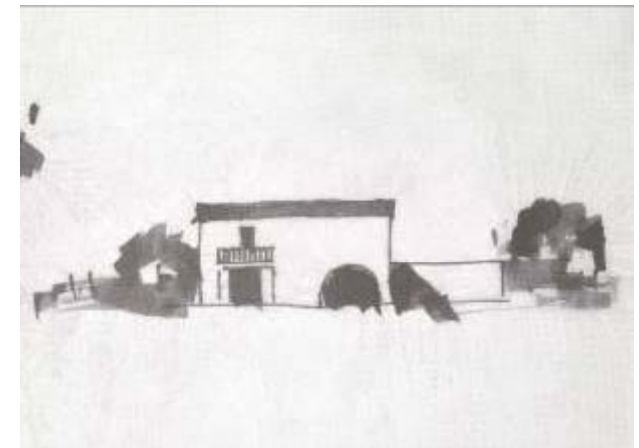

D. Ibler: kuća Robić, Korčula 1933.



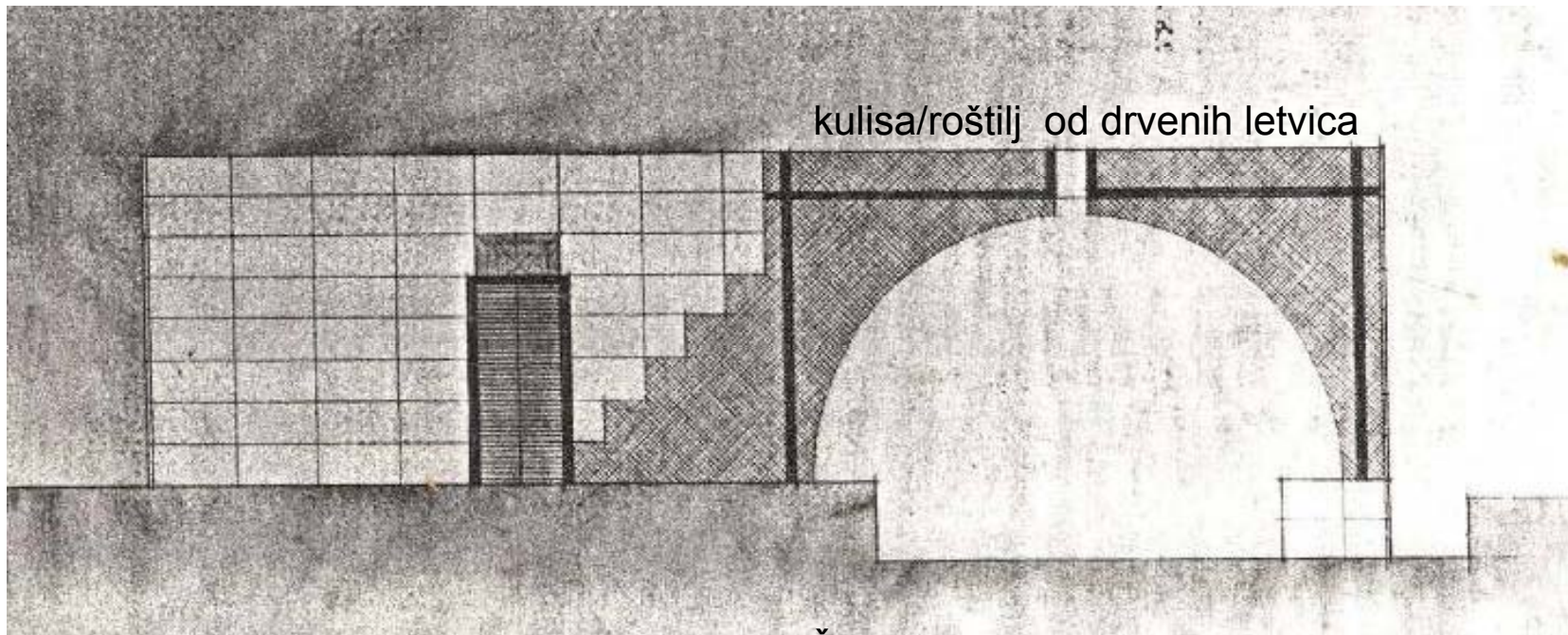

kulisa/roštilj od drvenih letvica

Nikola Filipović: Kuća Čilipi, 1980te



E. Legović: kuća u Istri, 1990te

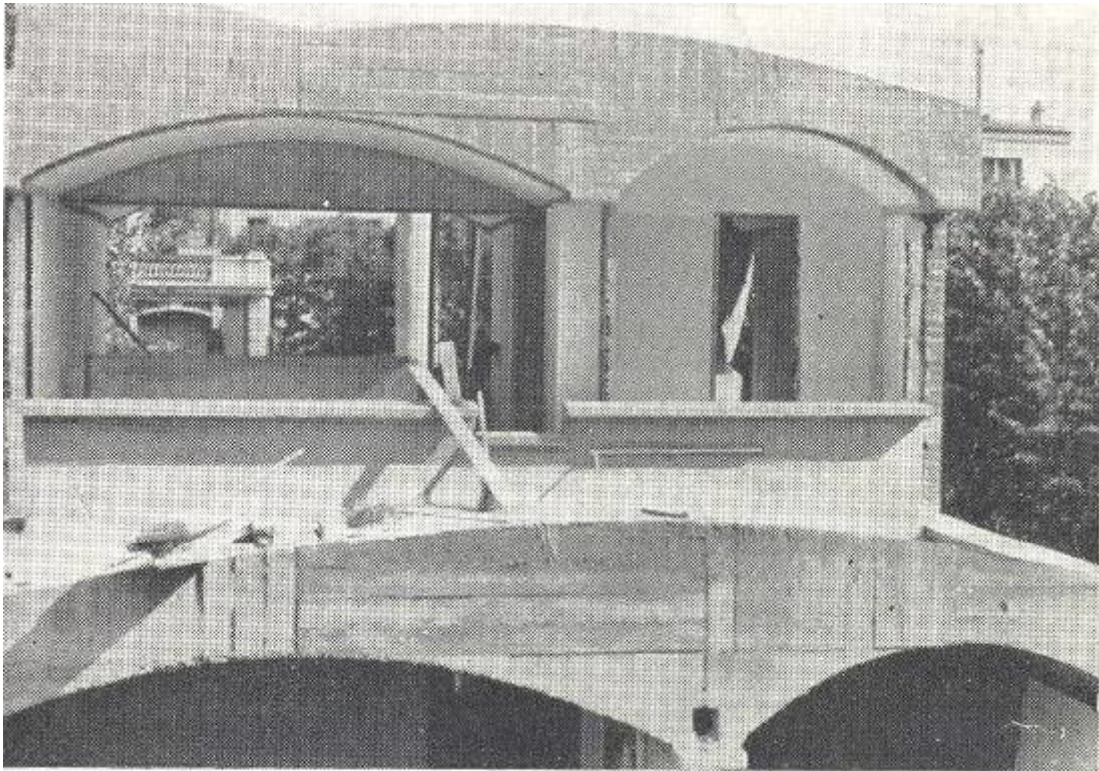

Le Corbusier: Maisons Jaoul, 1956.

/pretvorba Apolona u Dionizija?/

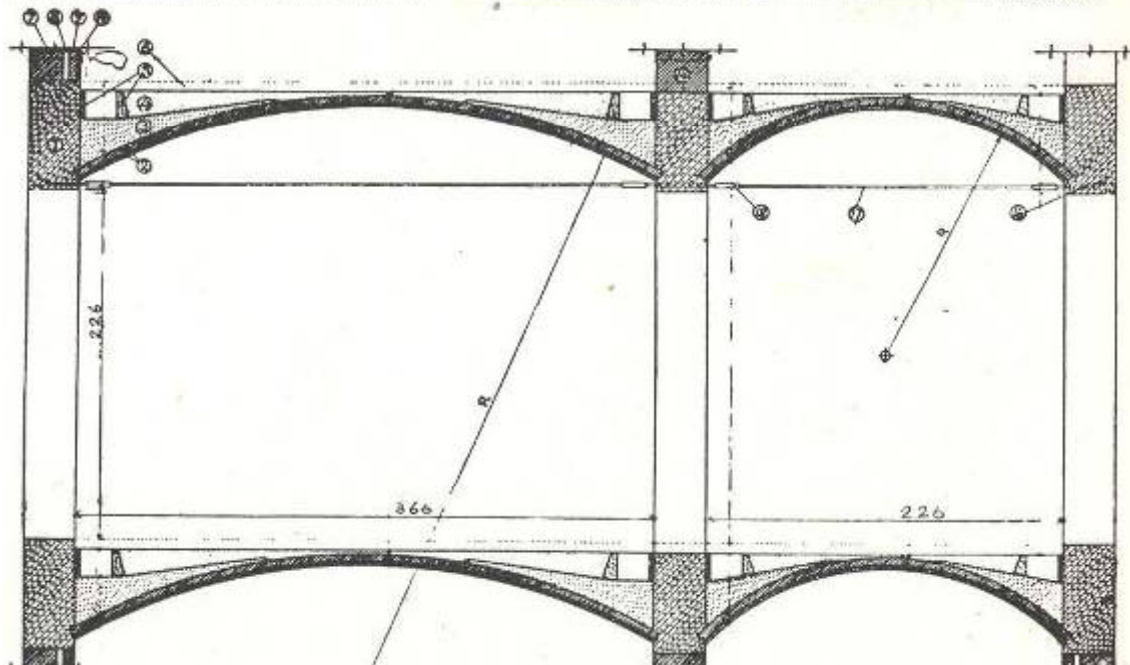

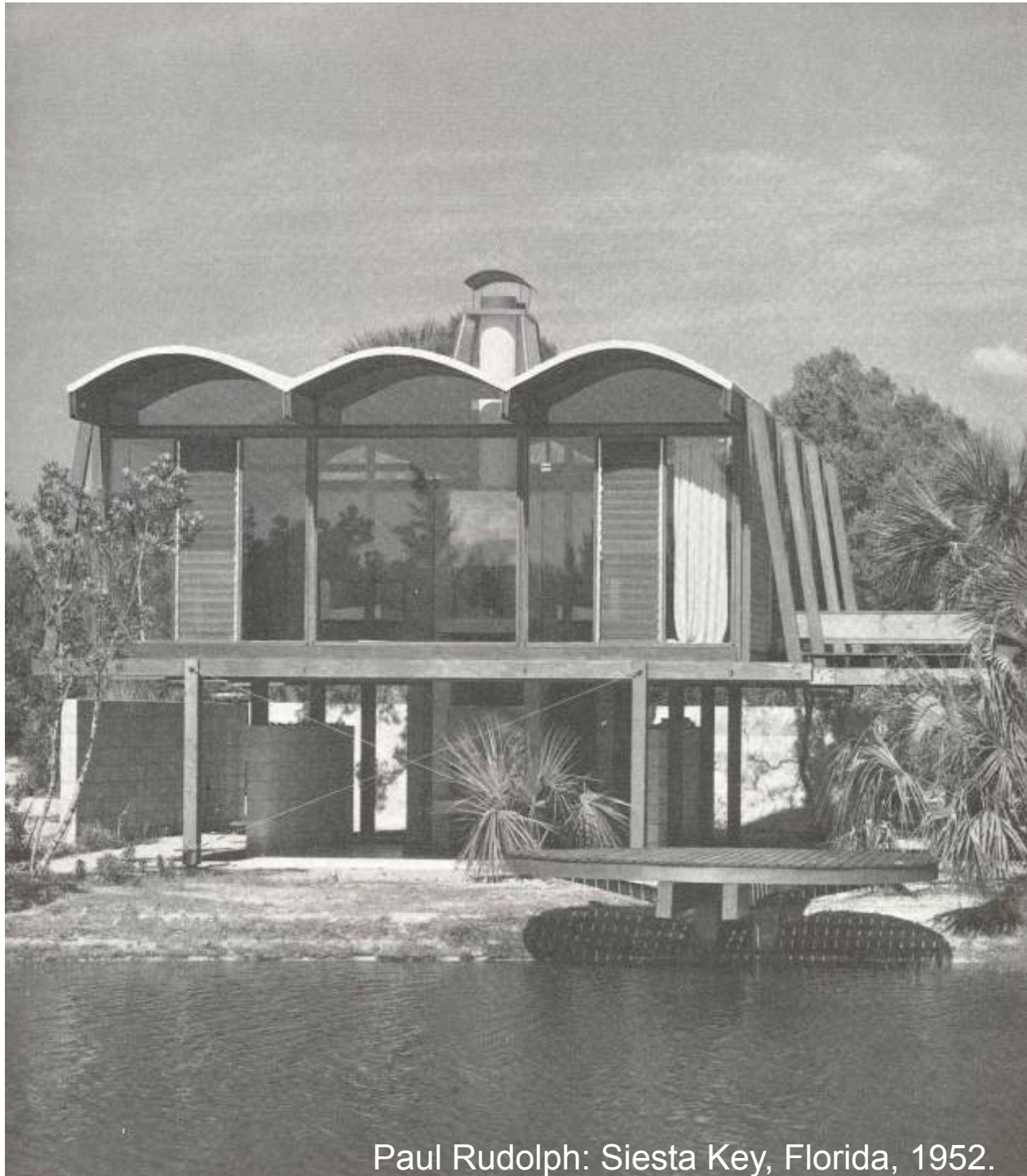

Paul Rudolph: Siesta Key, Florida, 1952.

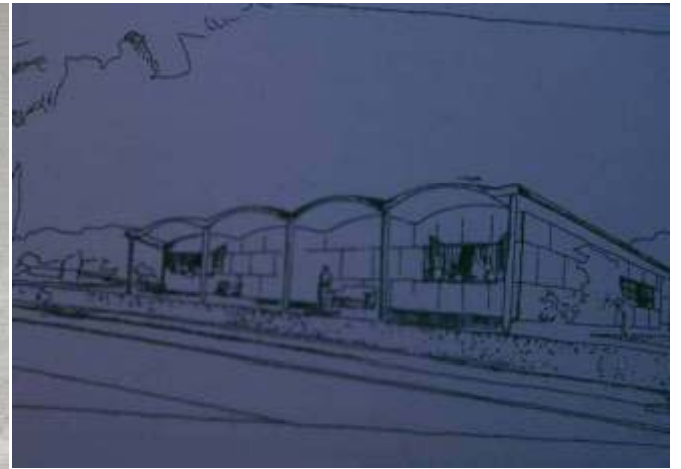

Le Corbusier

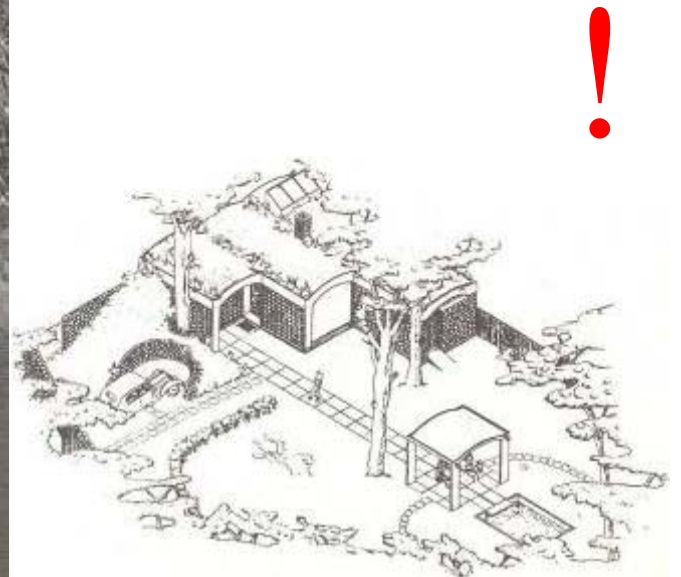



Paul Rudolph: Florida 1951.

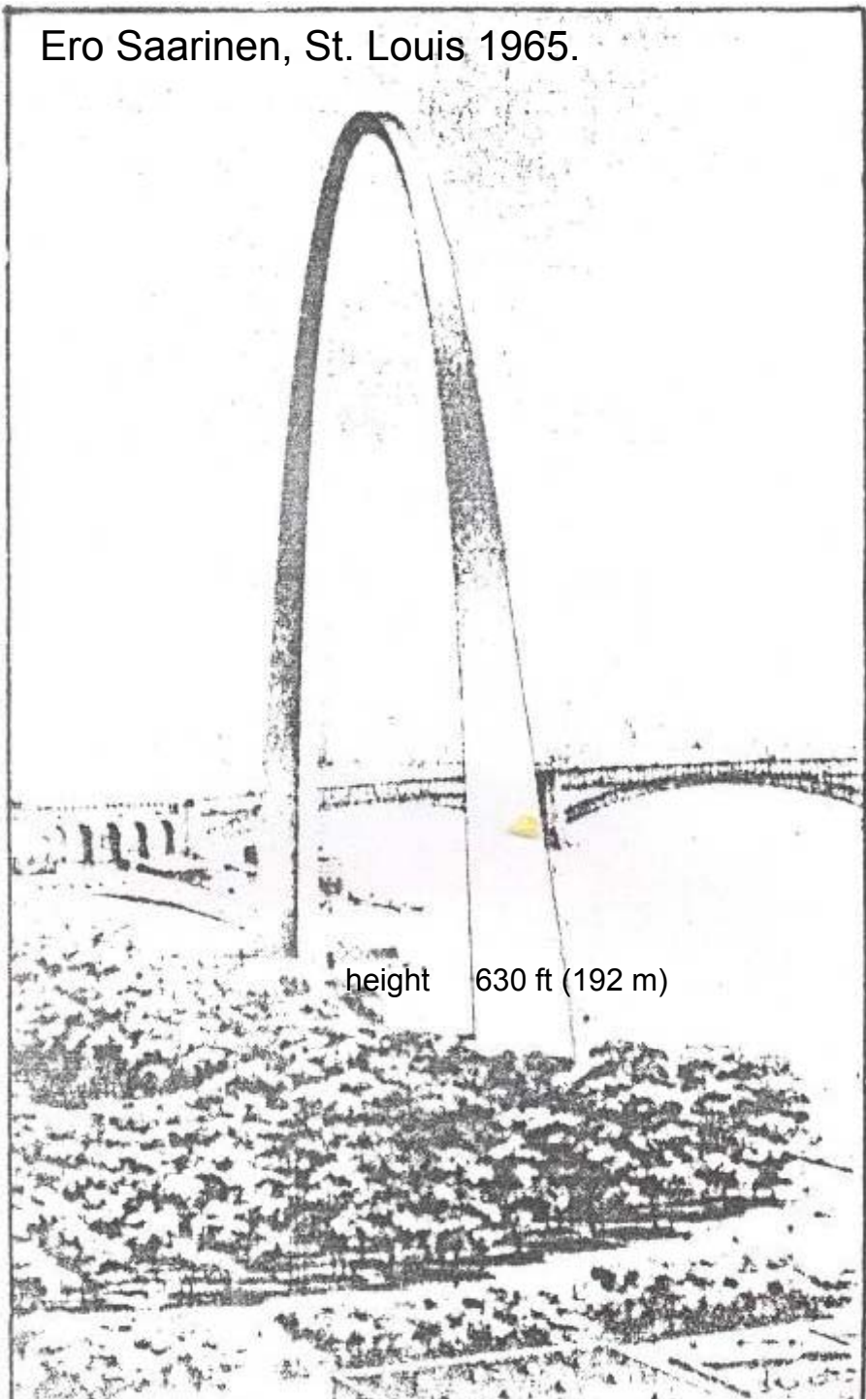
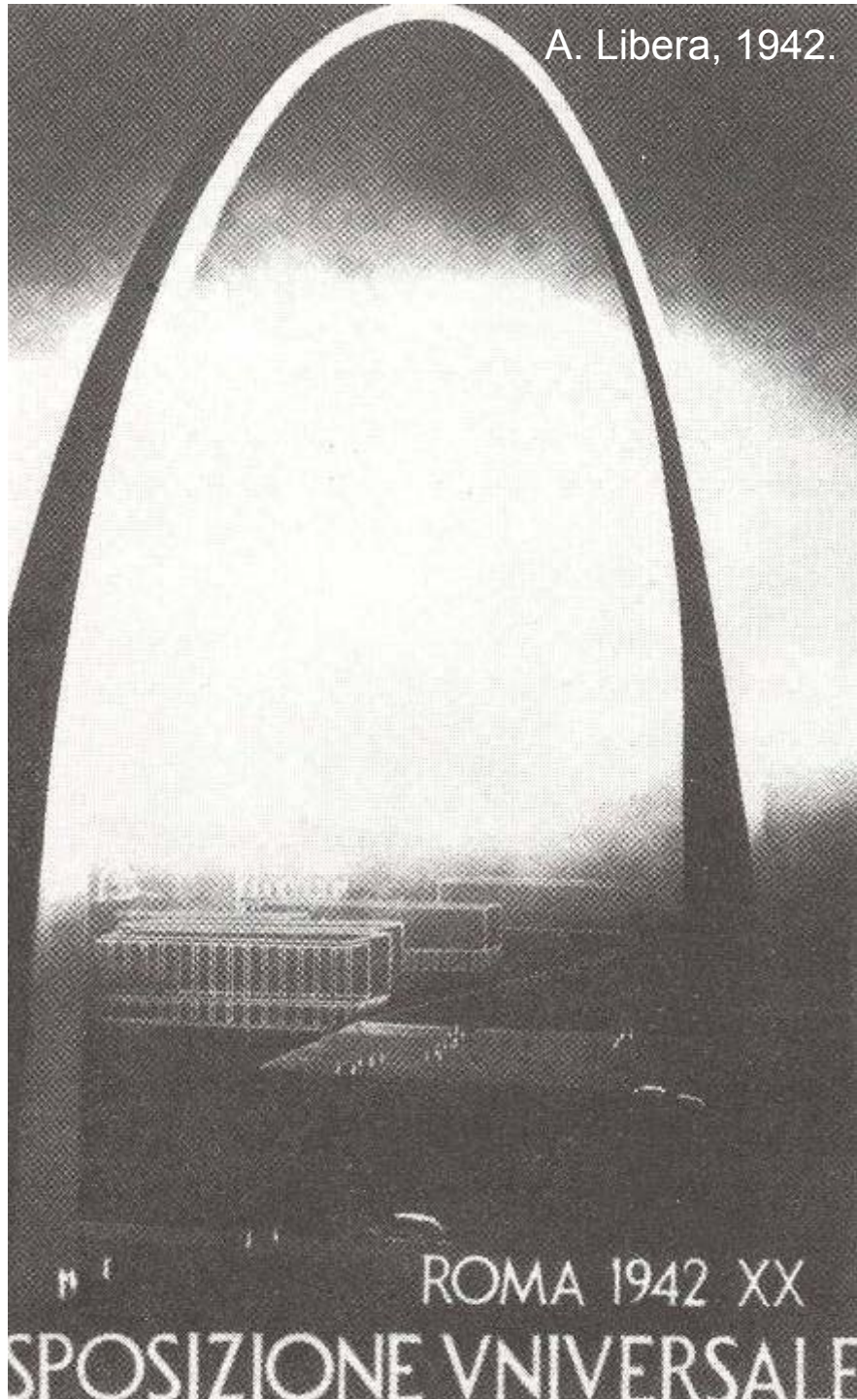

Orly, Paris, 1920te

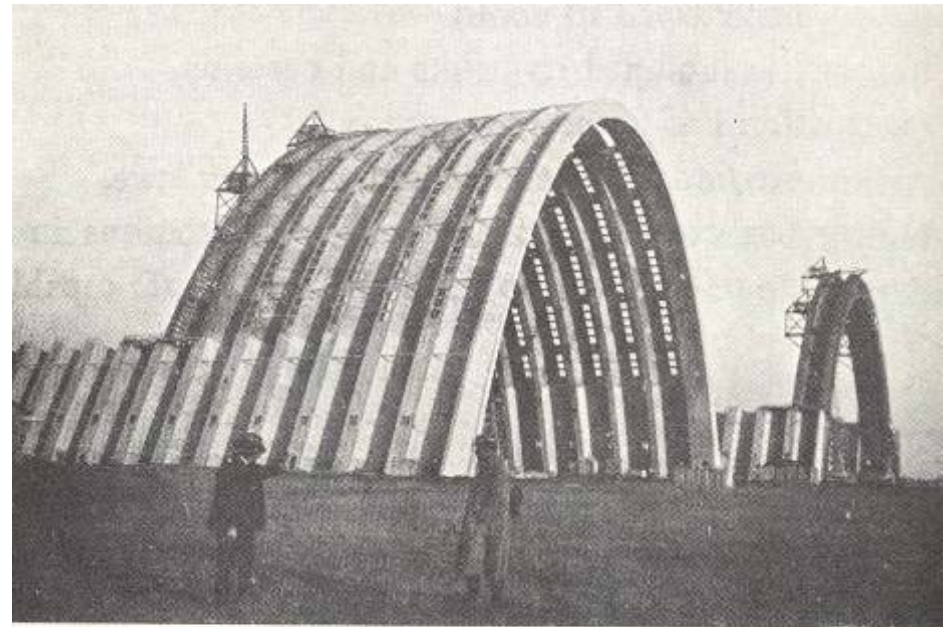
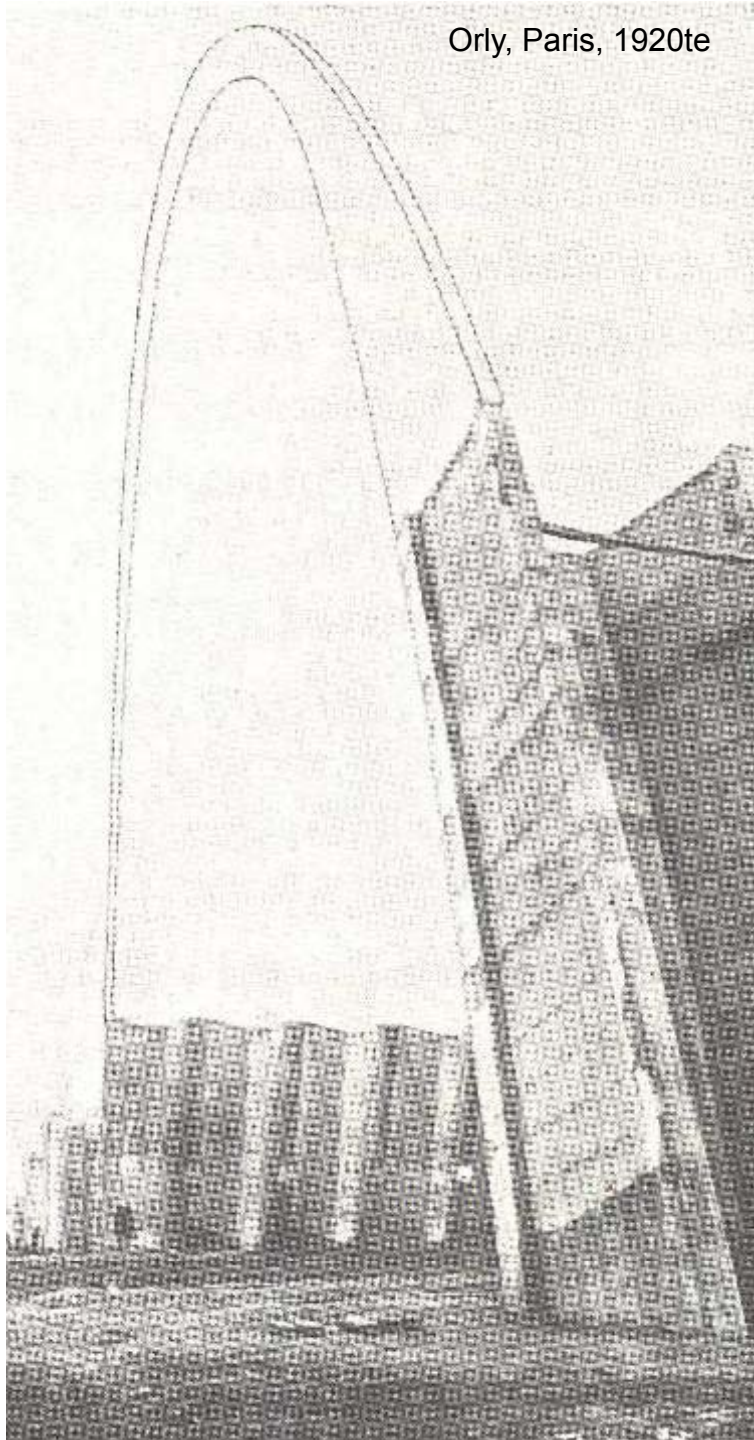

A HANGAR (FREYSSINET & LIMOUSIN)

*Width 250 feet, height 150 feet, length over 900 feet. The Nave of Notre Dame is 40 feet wide and about 107 feet in height.*

Le Corbusier: Palača Sovjeta, 1928.

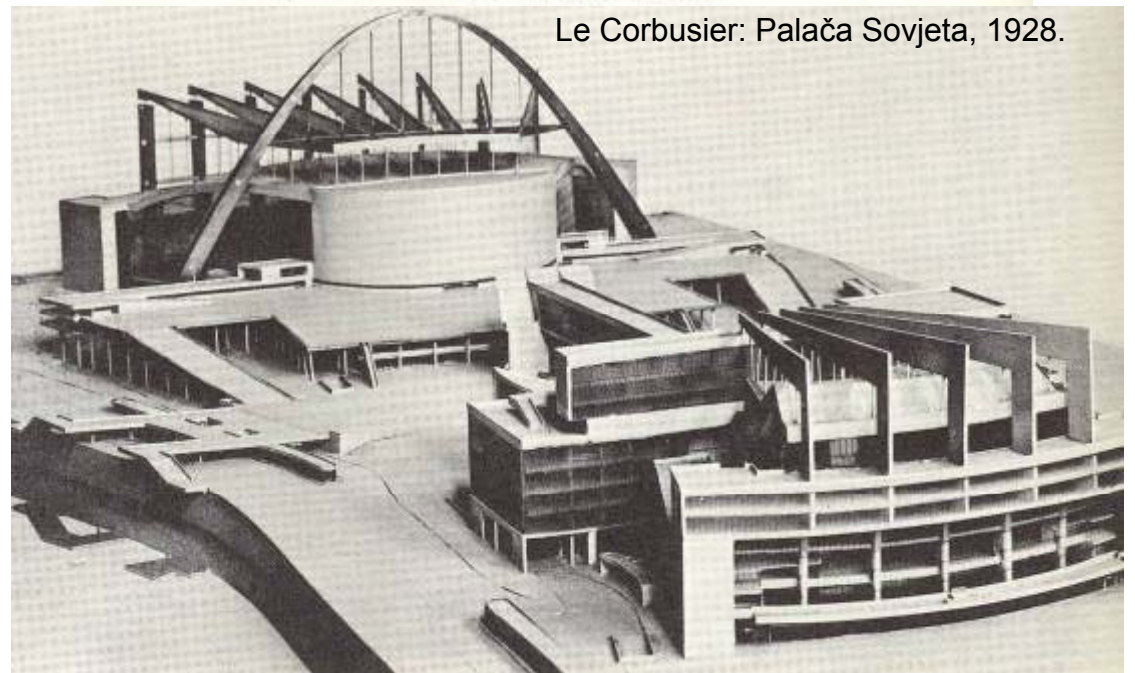



Bensh Hous, Berlin, 1935.

HANS SCHAROUN



“less”

“more”

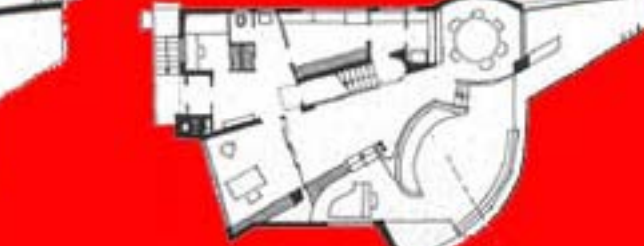
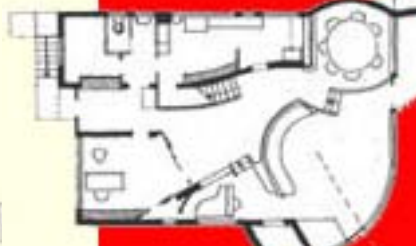



parcels 50 x100 ft  
kuća=cca 3500 sq ft

žičano pletivo

cigla

šindra

žbuka

staklo  
veliki formati

šperploča

profilirani aluminijski lim

brušeni beton

de-konstruktivizam

Frank Gehry: Own House, Santa Monica, LA, 1978.

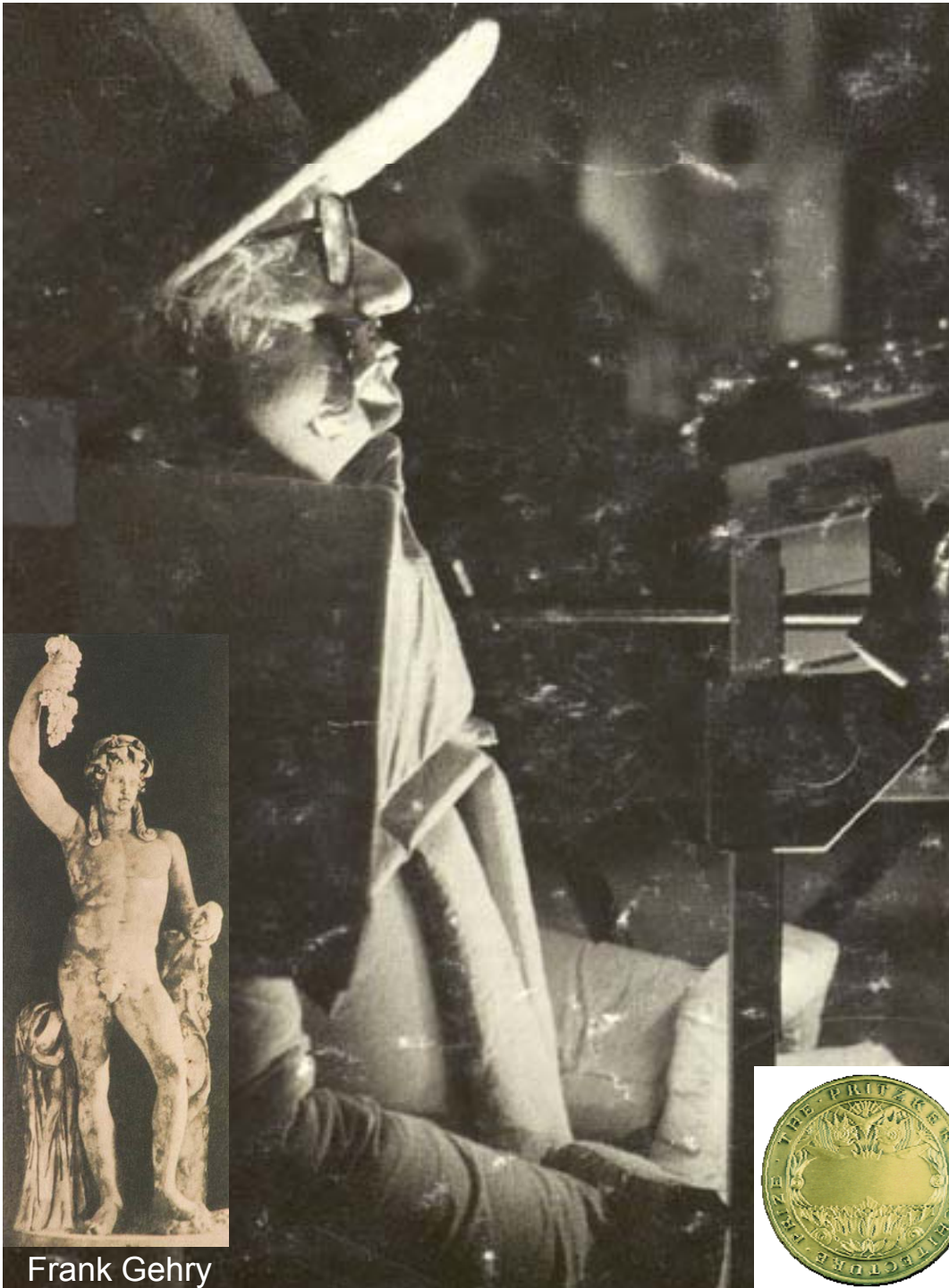

Frank Gehry

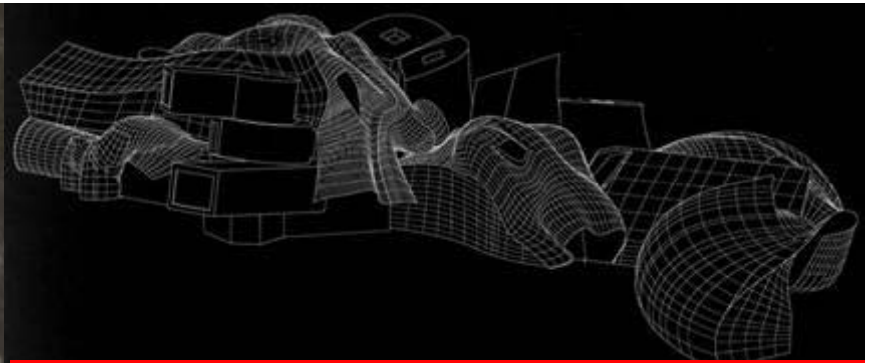

"no rule architecture"

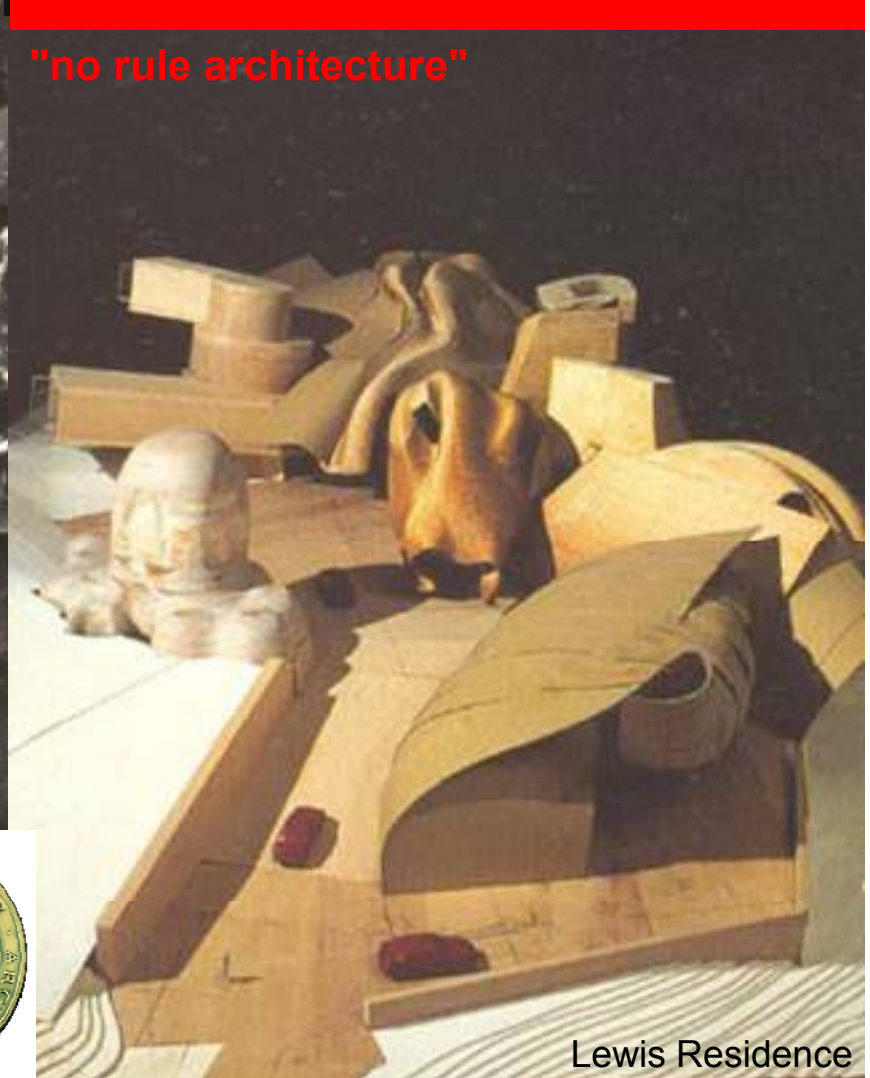

Lewis Residence





Frank Gehry & Philip Johnson: LEWIS RESIDENCE, Cleveland,USA,1996.



Picasso



Gehry



Picasso

**dekonstruktivism**



Coop Himmelblau: OPEN HOUSE, Malibu, California, 1985.

2,050 sq ft

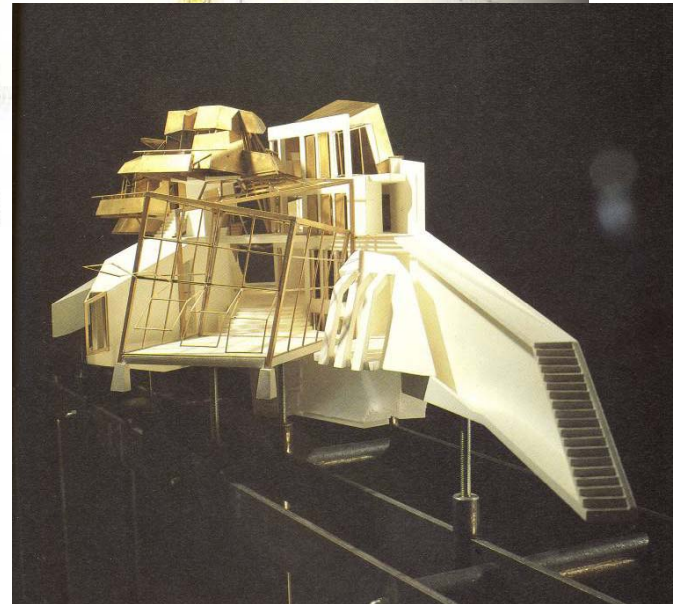
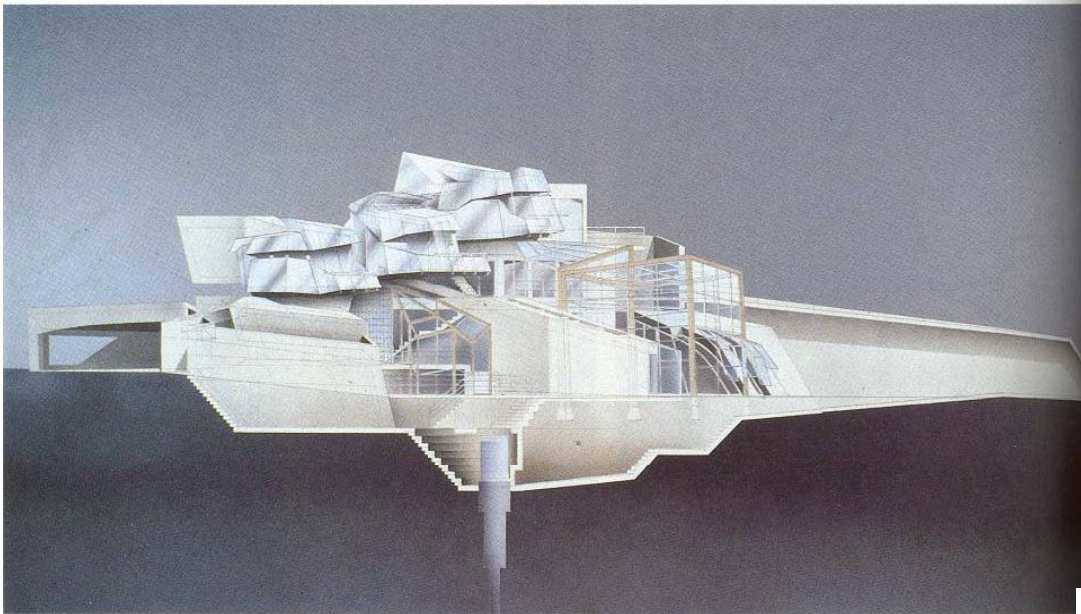
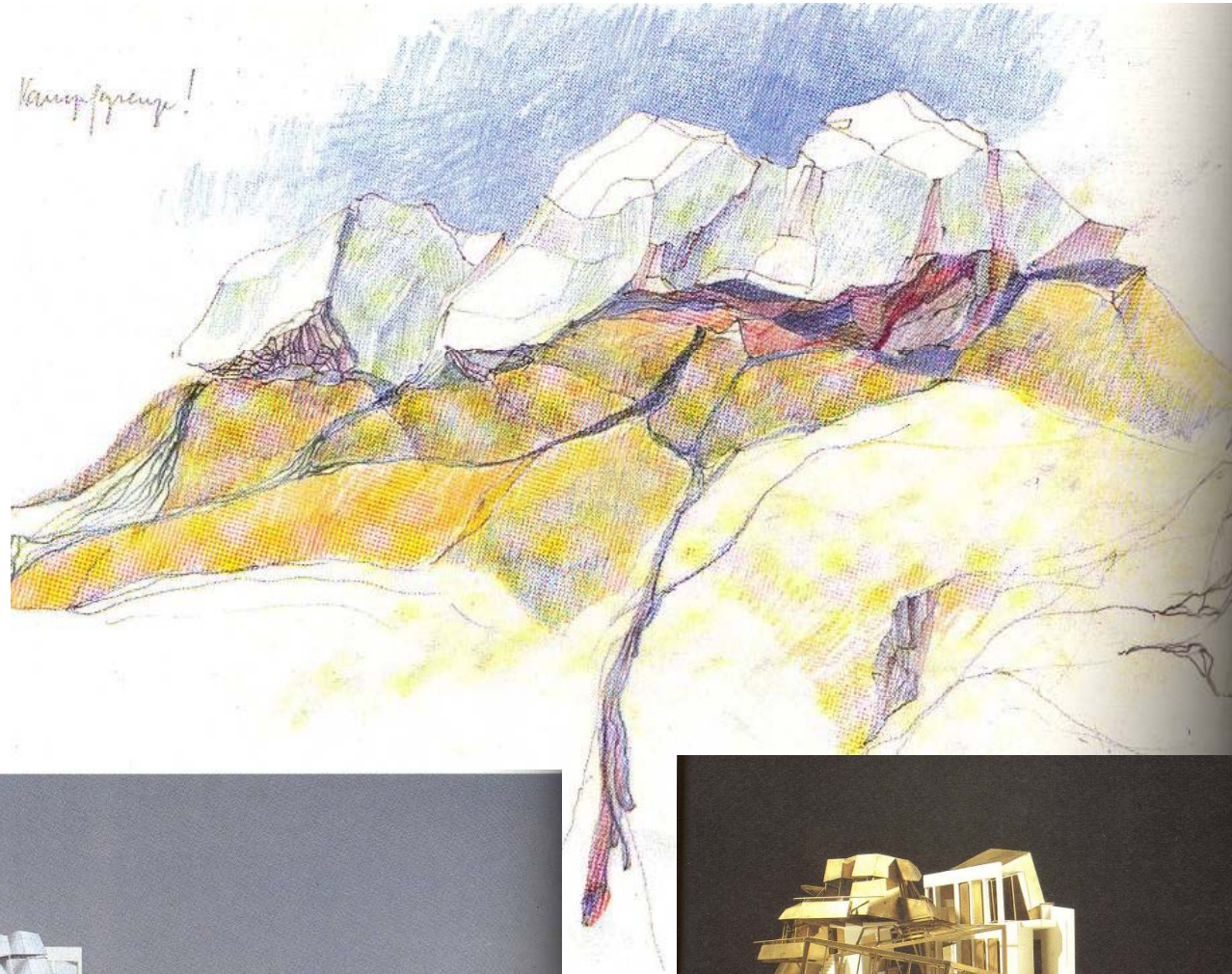

Gunter Domenig: Stain House, Austria, 1985.

**dekonstruktivizam**



**Gunter Domenig: Stain Hous, Austria, 1985- (gradnja nije dovršena)**

# retro-moderna

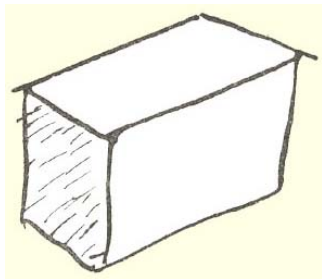

LeC: Garche, 1927. (žbuka)

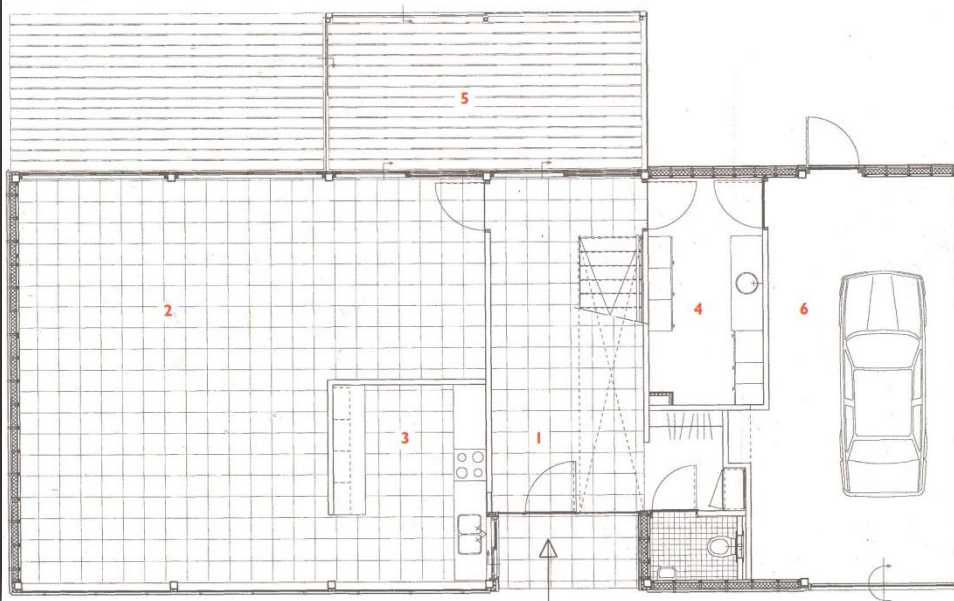
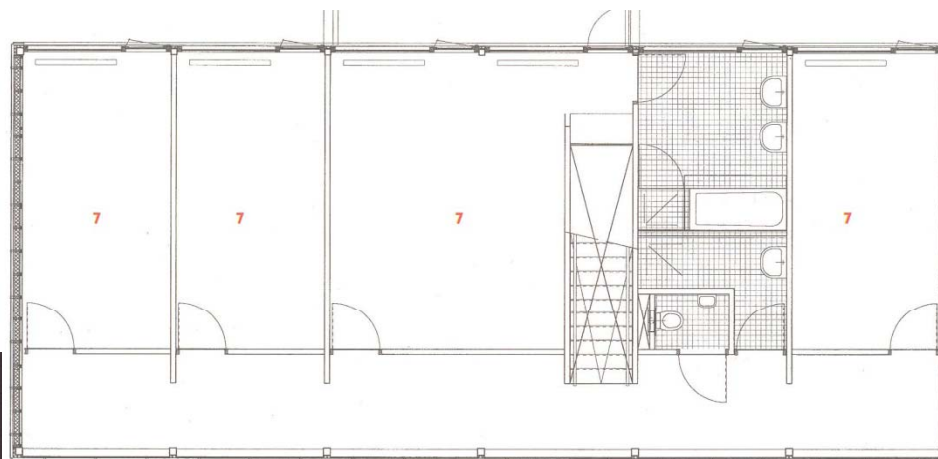

Dirk Jan Postel, Kraaijvanger-Urbis: ALMELO, NL, 1997.

comp.  
kuće Tadao Ando (beton)  
kuće Mario Botta (cigla, bloketa)



staklena opeka  
čelični stupovi  
perforirani lim  
duraluminij  
čepasta guma

prva **HIGH-TECH** obiteljska kuća

Pierre Chareau: MAISON DE VERRE, 1928-31. Paris

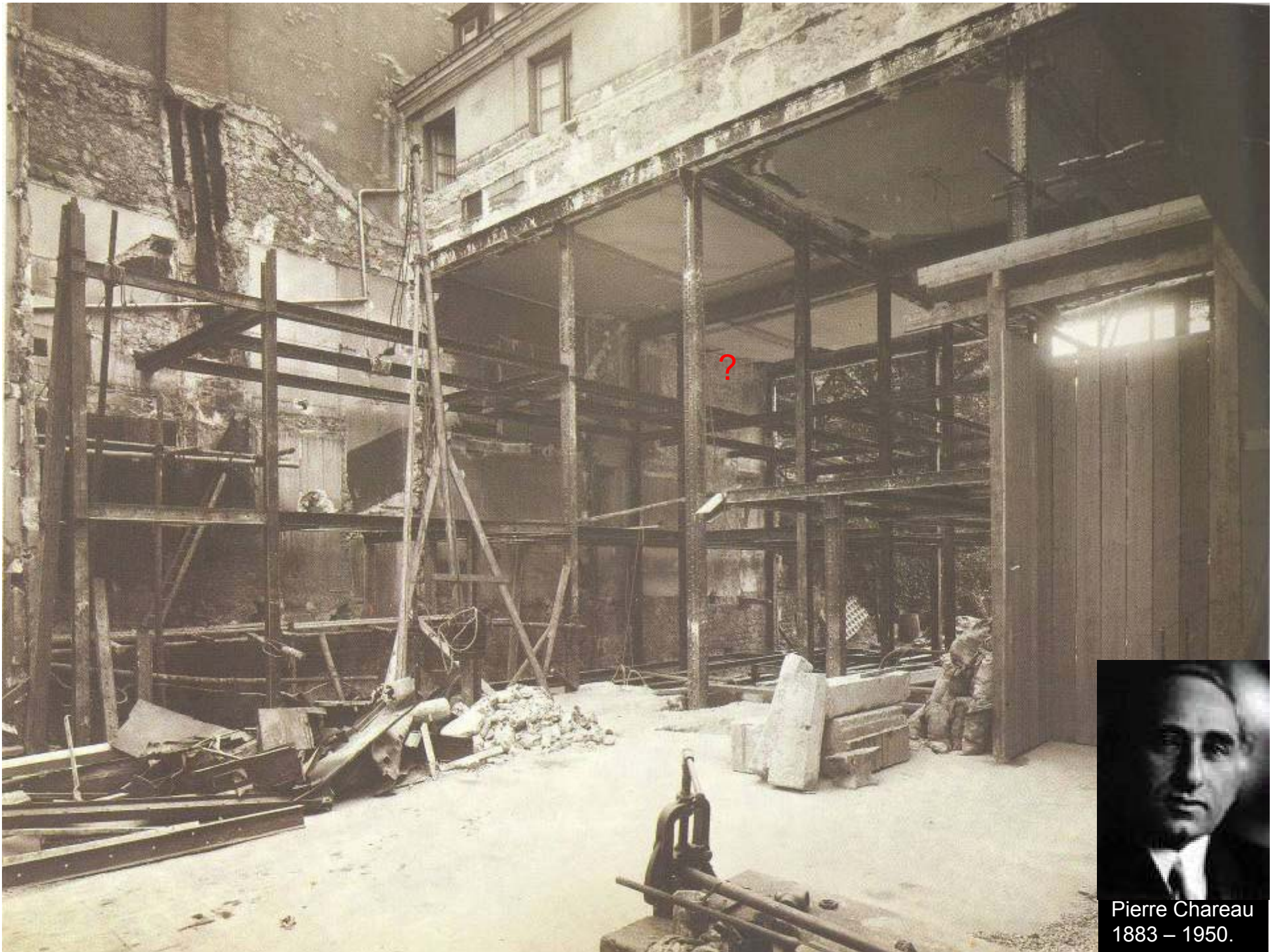

Pierre Chareau  
1883 - 1950.



staklena opeka  
čelični stupovi  
perforirani lim  
duraluminij  
čepasta guma



- “klimatizacija interijera”
- mobilne police za knjige
- ormari s obostranim vratima
- zaokretna WC školjka
- rotirajuća vrata
- ormari s 5 pokreta
- kupaoničke police s knjigama
- mobilne ljestve
- vanjski reflektori prema kući
- ovješeni poslužavnik



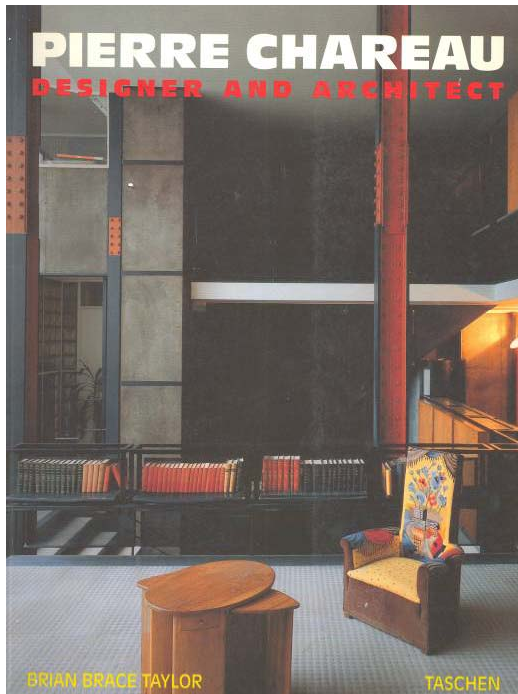

- “klimatizacija interijera”
- mobilne police za knjige
- ormari s obostranim vratima
- zaokretna WC školjka
- rotirajuća vrata
- ormari s 5 pokreta
- kupaoničke police s knjigama
- mobilne ljestve
- vanjski reflektori prema kući
- ovješeni poslužavnik

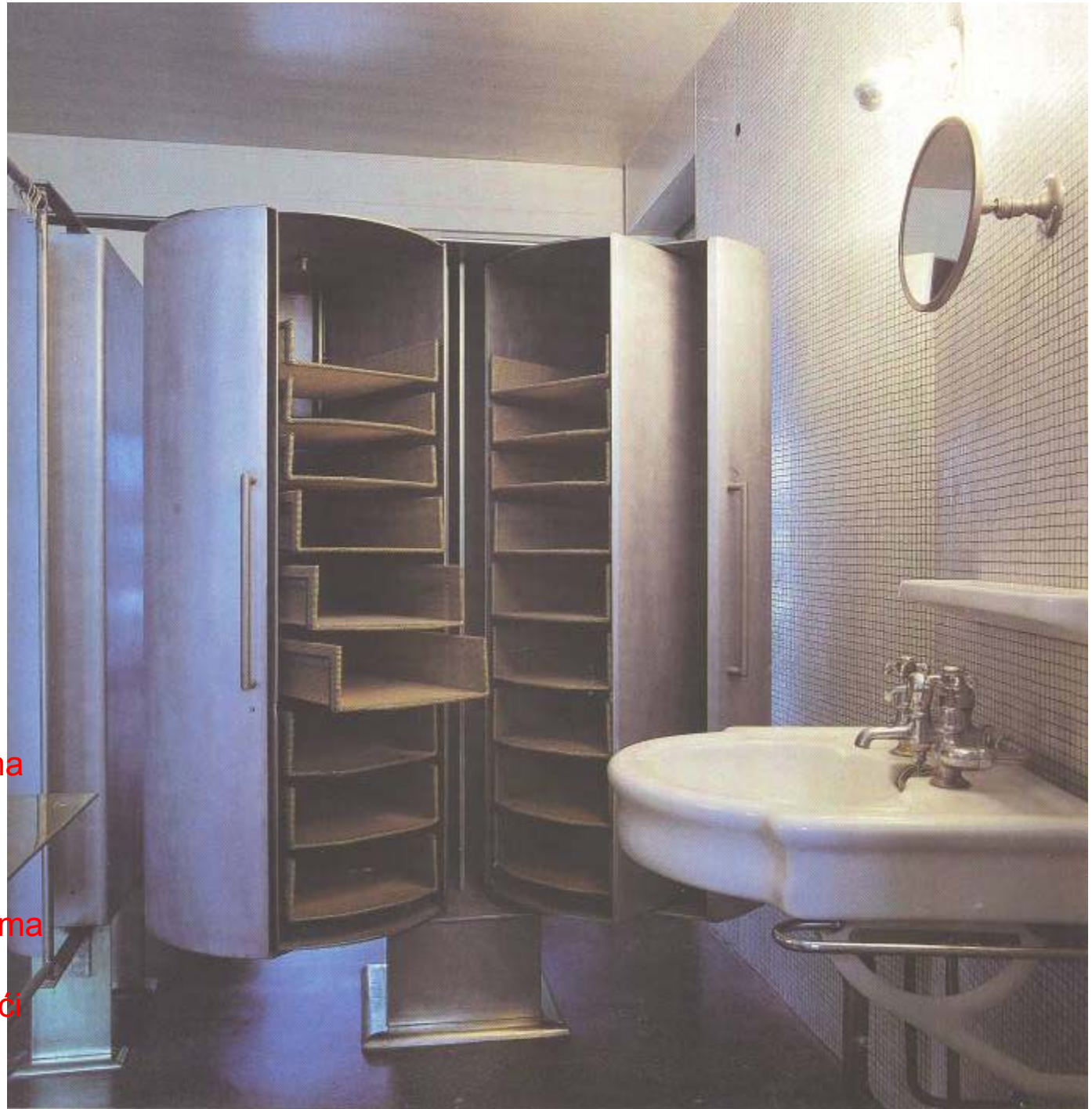

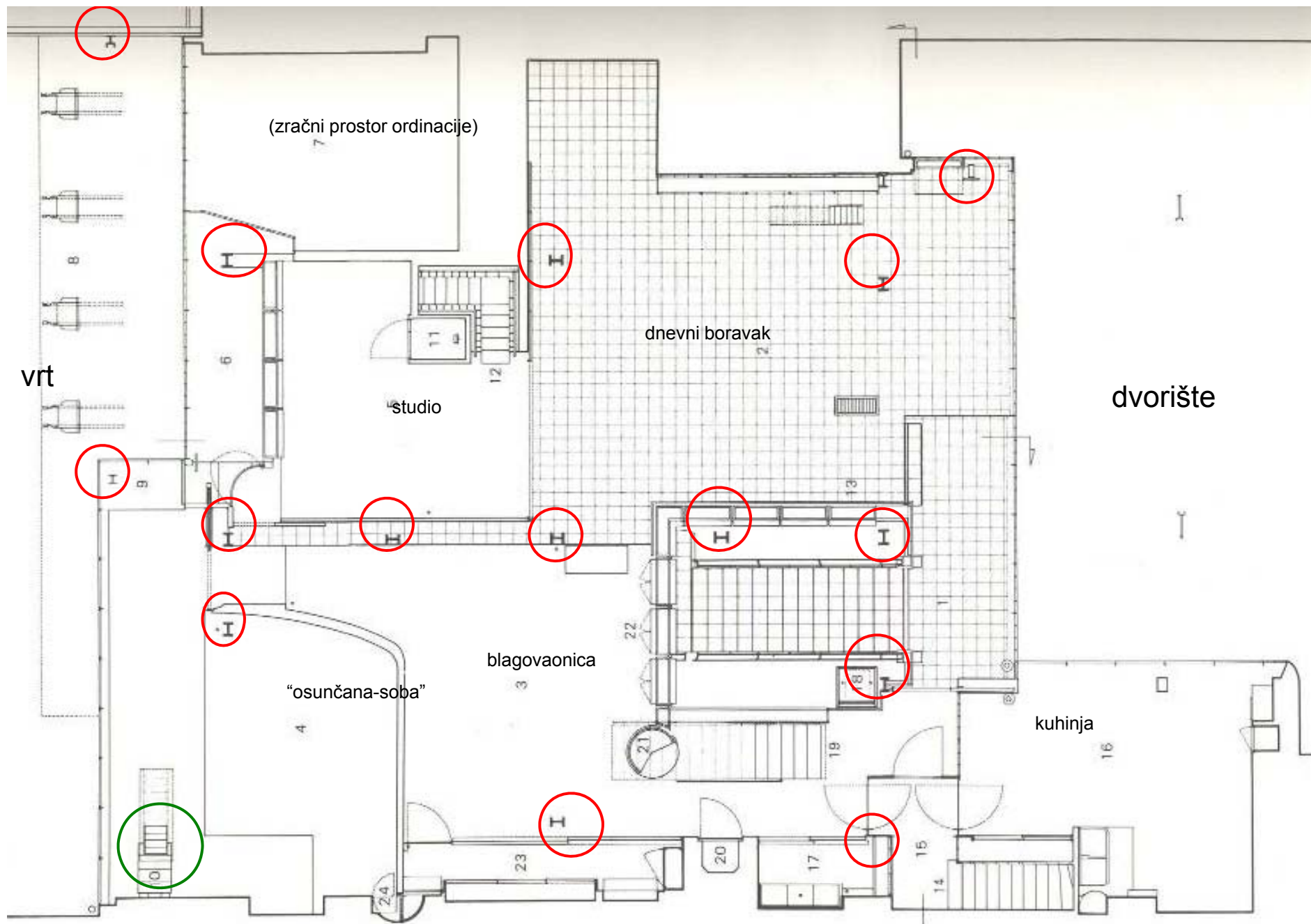

Pierre Chareau: MAISON DE VERRE, 1928-31. Paris,- tlocrt 1.kata

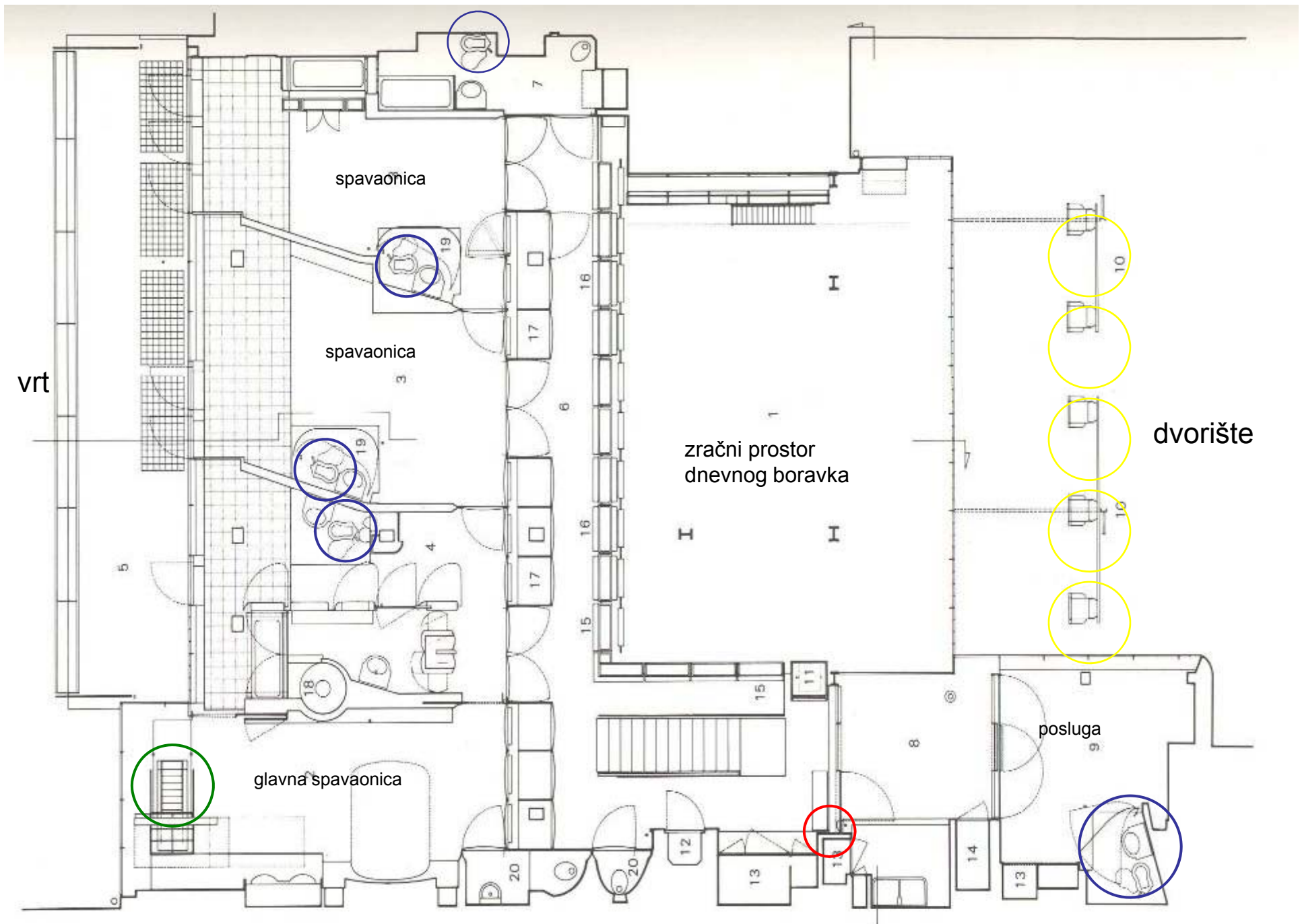

Pierre Chareau: MAISON DE VERRE, 1928-31. Paris tlocrt 2.kata



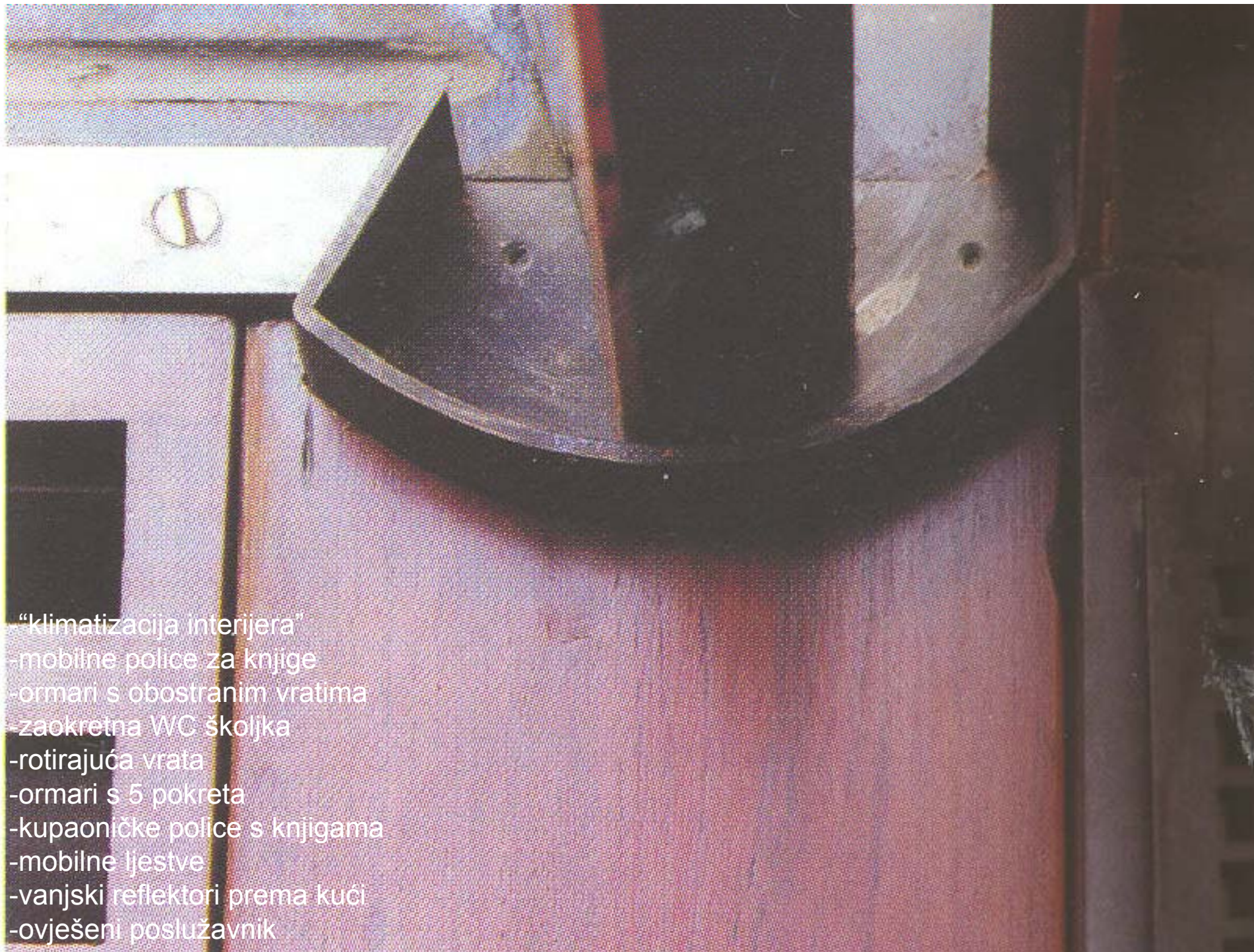

- "klimatizacija interijera"
- mobilne police za knjige
- ormari s obostranim vratima
- zaokretna WC školjka
- rotirajuća vrata
- ormari s 5 pokreta
- kupaoničke police s knjigama
- mobilne ljestve
- vanjski reflektori prema kući
- ovješeni poslužavnik

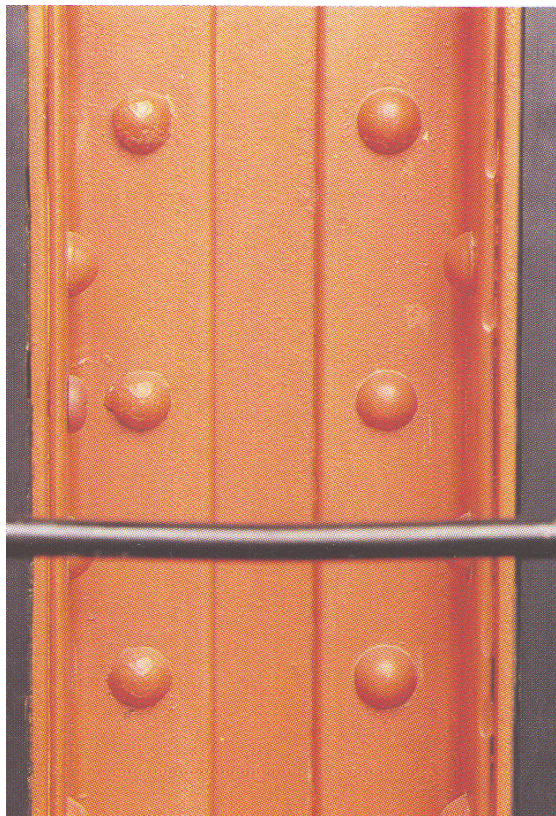
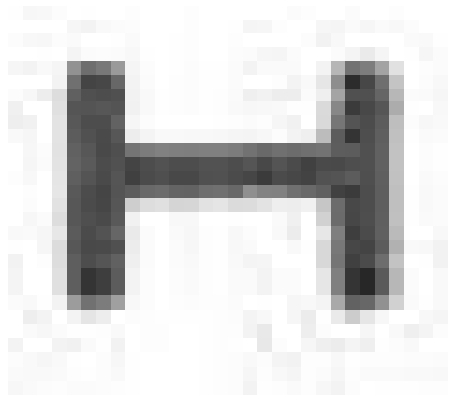

(“industrijska arhitektura”)





SVAKOM VREMENU NJEGOVA UMJETNOST  
SVAKOJ UMJETNOSTI NJENA SLOBODA

**Less is more\***

\* Laisse, c'est mort !

L. Mies van der Rohe

Grapheine

Less is bore

(future😊)

**MORE**  
— with —  
**LESS**  
— is —  
**MORE**

(material & energy)

**Sou Fujimoto: House N / Oita, Japan, 2008.**

Site Area: **236,57 sqm**

Constructed Area: **150,57 sqm**

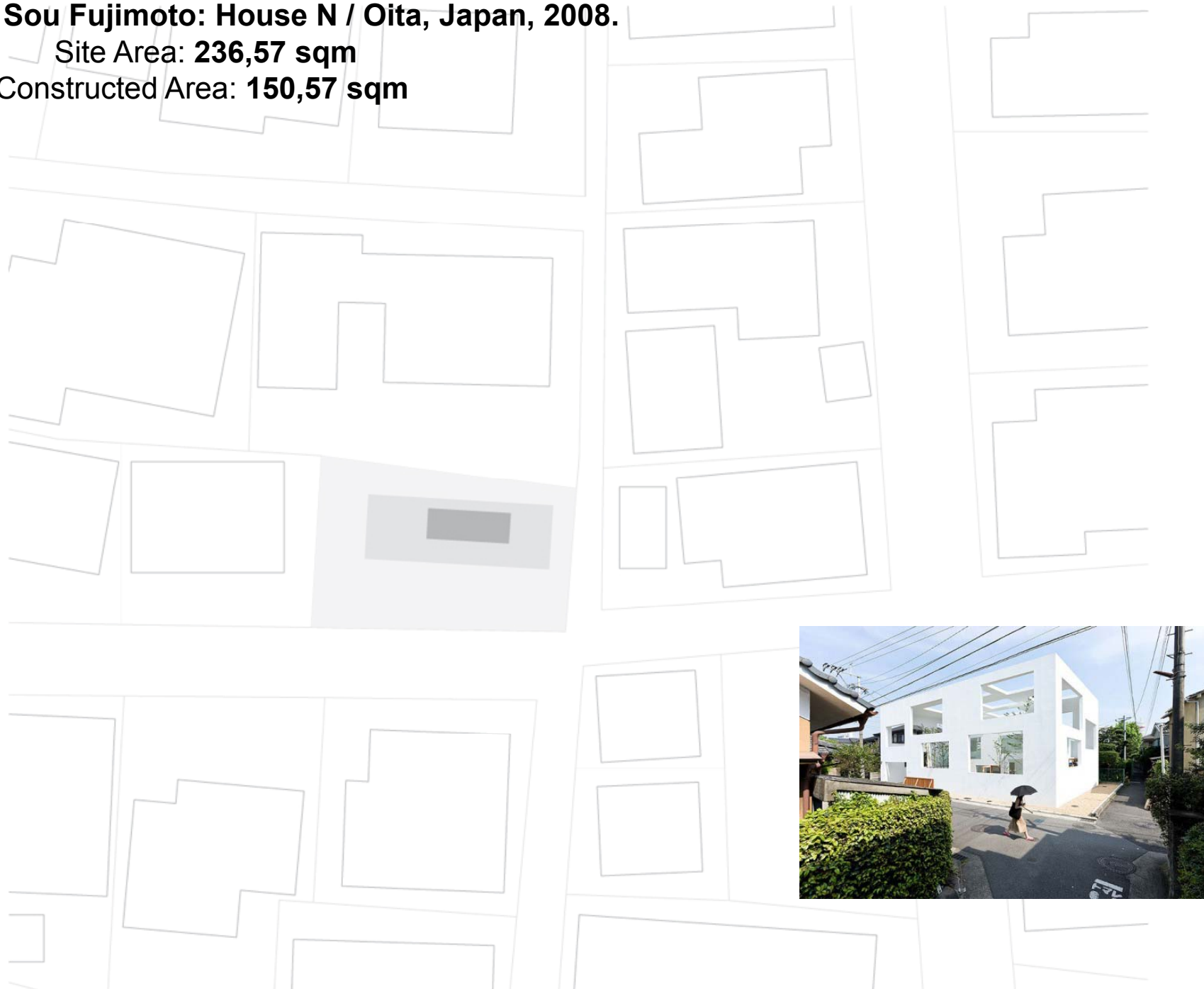

(stil-2013 =?)



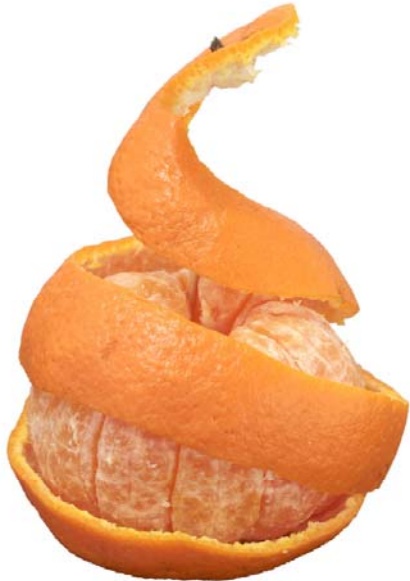
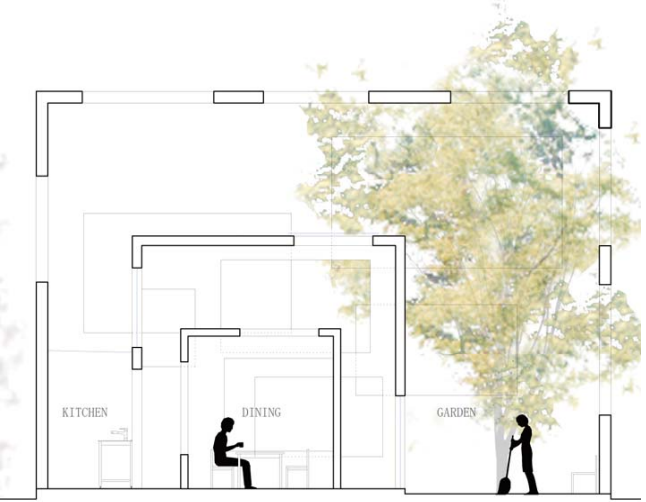

vidi:  
Lenko Pleština :UKUTIJAVANJE OBITELJSKIH KUĆA  
/”Prostor”



ZIMMERMANN RESIDENCE Fairfax, Virginia



MLTW/Turnbull Associates. 1975

The clients wanted a bright, light-filled house with lots of porches.

We designed a house that is also a porch. The outer "porch house" is a timber structure sheathed in redwood lattice and covered by a translucent plastic roof.

Sheltered within sits an "inner house" designed for specific functions.

The translucent roof - a giant skylight - fills the inside of the porch house with natural light, while a light tower from the inner house projects through the roof to flood the interior with light.



Villa Karma, 1904-1906

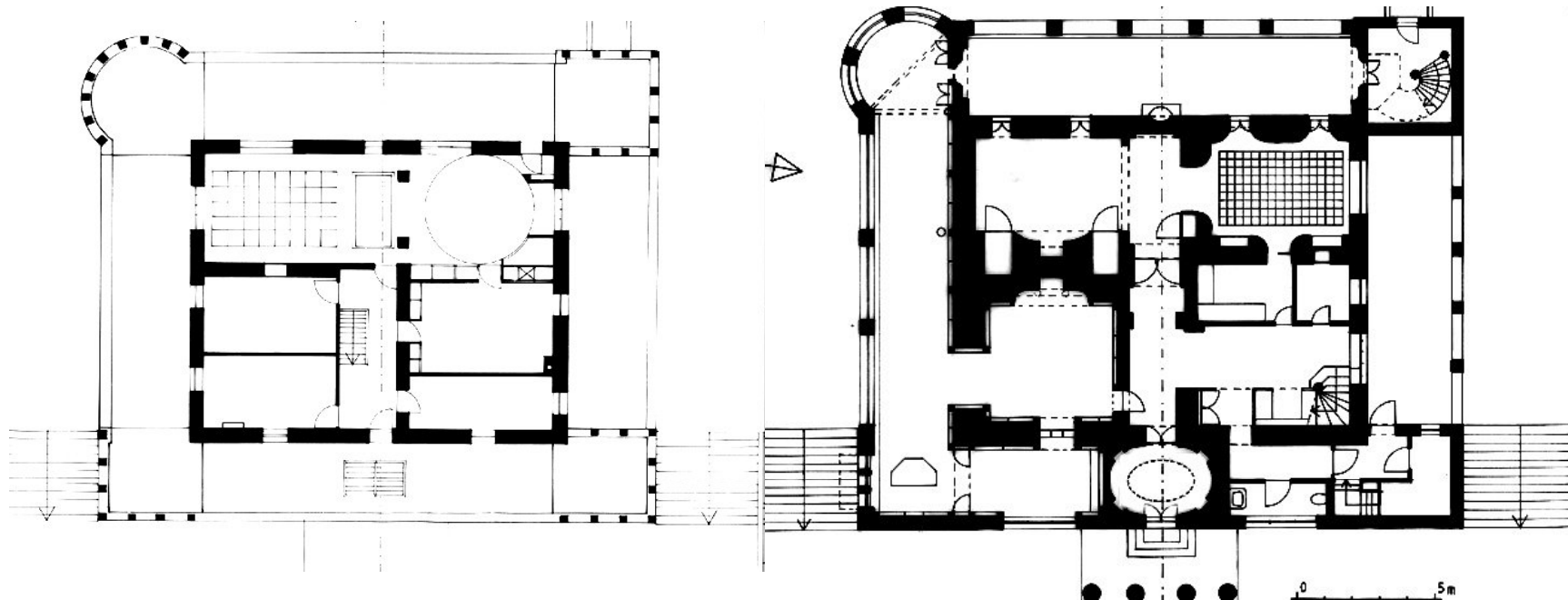
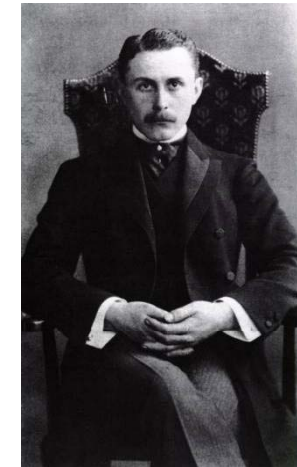
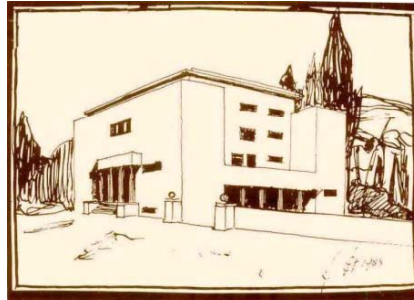

First the psychiatrist Theodor Beer asked the Swiss architect **Lavanchy** to make some alternations to the house Maladaire which was situated near the border of the lake of Geneva. He had to design a peel around the exist-ing house which would become the core of the new house. In this rind that should measure about 3 meters **Loos** was asked to design several rooms like bathrooms, library's and the loggia. Later on Loos also changed the exterior, like the round tower. At last a third architect **Ehrlich** has given the house the final look. The loggia's were closed with glass. Since 1948 the house no longer is named Karma but Harma.



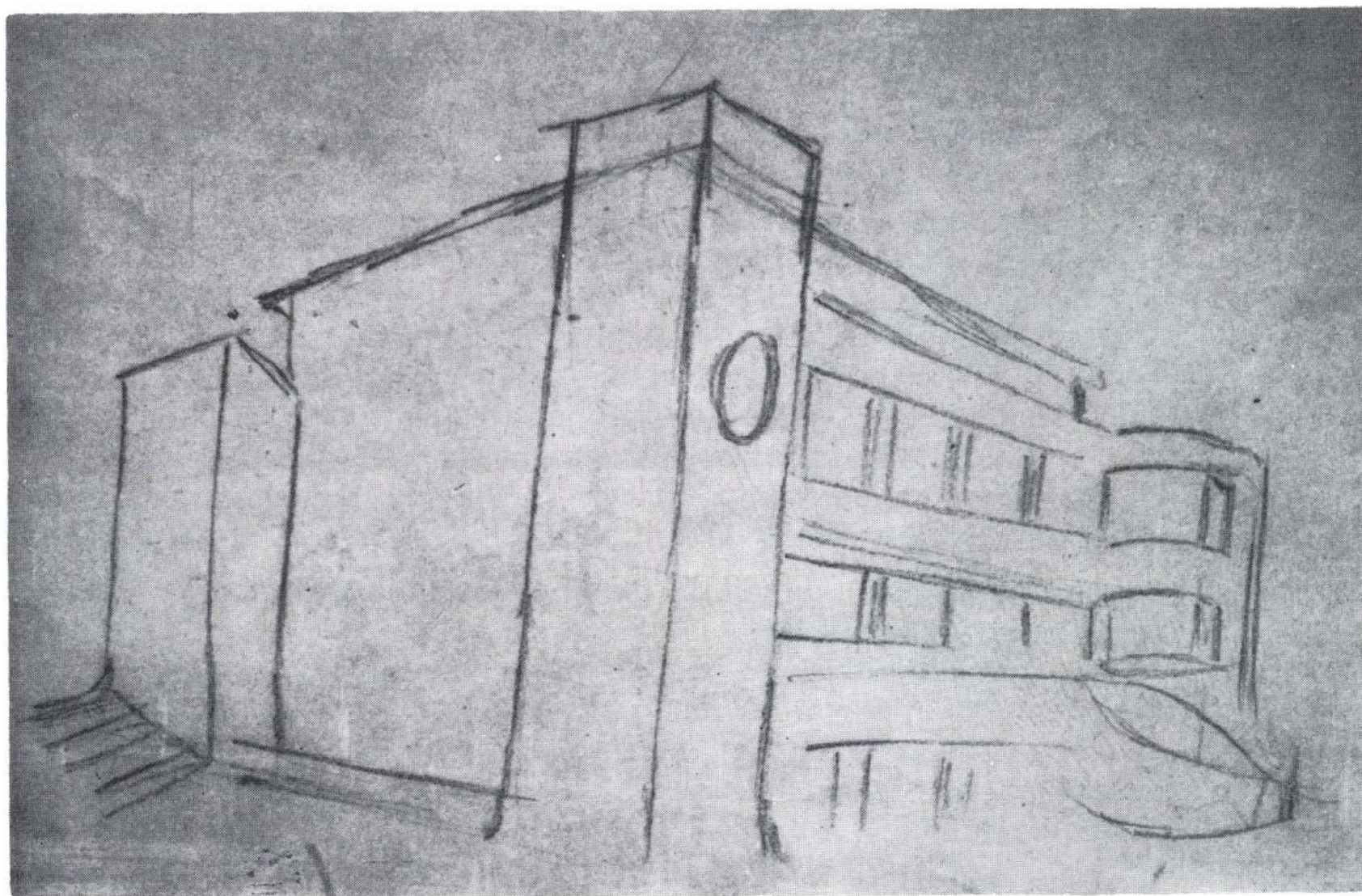

*KARMA, idejna skica A. Loosa. Beč, Loosov arhiv*



Priča kaže da je kuća nastala kad su tri brata pomorca iz obitelji **Vuković** oženili tri Španjolke i odlučili sagraditi veliku kuću (Palac) na svojoj zemlji. No, na toj zemlji se nalazila kuća težaka **Marka**. Braća su Marku ponudila veliki novac za otkup, ali Marko kuću nije želio prodavati. Propalo je i posredovanje tadašnjeg načelnika kojem je Marko zaprijetio smrću, pa je zbog straha od odmazde morao pobjeći iz Bola u **Dubrovačku Republiku**, .....(znači prije 1808.) Braća su tada započela gradnju oko Markove kuće, te su podigli tri kata i još su samo trebali postaviti podove i krov te srušiti Markovu kuću. Otputovali su u Mletke po drvenu građu, nakrcali brod i krenuli nazad prema Bolu, ali ih je na povratku uhvatilo veliko nevrijeme i potopilo brod. Kako nijedan od braće nije imao djece, ugasio se rod Vukovićevih, a težak Marko se nekoliko godina nakon toga vratio živjeti u svoju kuću, danas poznatu kao 'Kuća u kući'.