

FUNKCIONALNA OBILJEŽJA OBITELJSKE KUĆE -

19.XI,2013.

Adolf Loos *Ornament und Verbrechen* (1908)



Louis Sullivan: **“FORM FOLLOWS FUNCTION”**

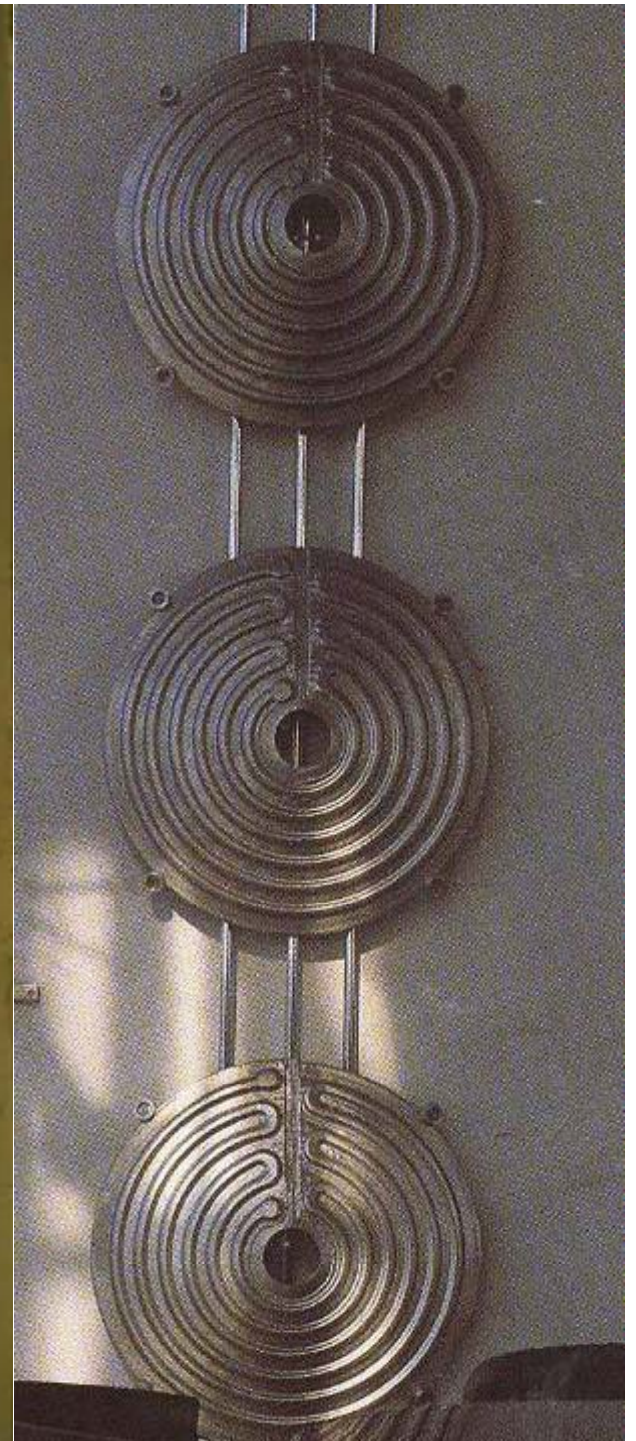

“Usporedba kuće i tijela:
uši= tornjići
oči = prozori
želudac=peć

Židovska enciklopedija, 18.st.”

izvor: Karl Jung:



analogno ,moglo bi biti::
-tjeme,kosa=krov
-kosti= konstrukcija
-krvotok=razvod energije
-probava=instalacije
-dišni organi=ventilacija
-koža=vanjska opna kuće
LP

The City and the House (Alberti)

“If the city is like some large house and the house in turn like some small city, cannot the varied parts of the house ... be considered miniature buildings?”

- Leon Battista Alberti (1404-1472)

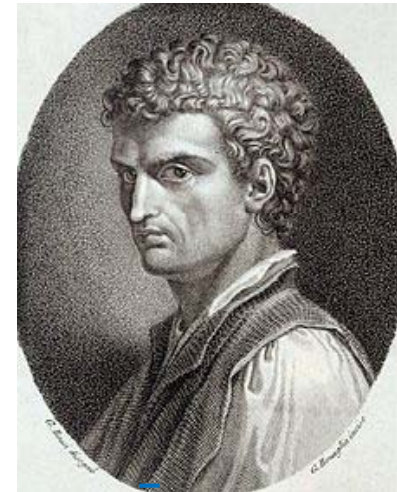
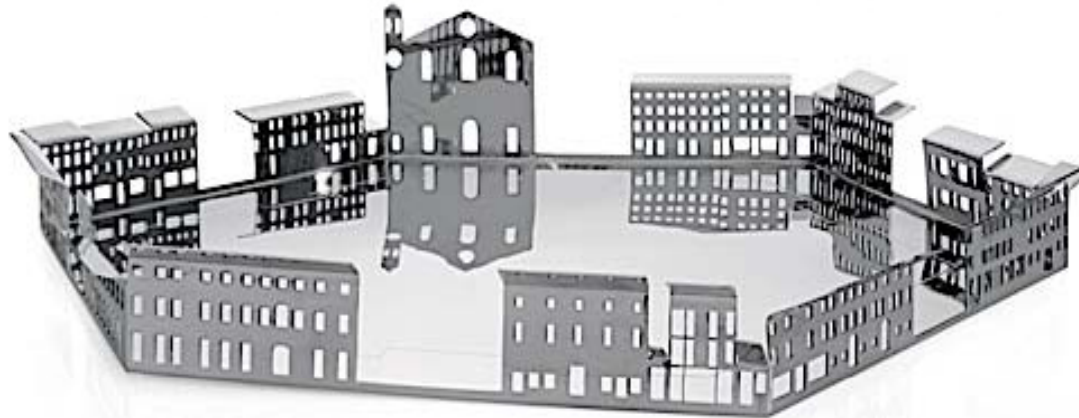

ulazni prostor.....=

hodnik, degažman, hall,foyer.....=

dnevni boravak, salon=

blagovaonica,=

kuhinja.....=

izba,=

gospodarstvo.....=

spavaonica.....=

kupaonica.....=

radna soba,biblioteka.....=

hobby room.....=

gym,sauna, bazen.....=

kotlovnica,gorivo,.....=

spremišta.....=

posluga.....=

garaža (*konjušnica*).....=

terasa, balkon, loggia.....=

vrt.....=

vrtna ograda.....=



Richard Hamilton (collage 1956)

Just What Is It that Makes Today's Homes So Different, So Appealing

MODERNO : FUNKCIONALNO =?

- *“Postoji jedna ideja FUNKCIONALIZAM koja se često povezuje s MODERNOM arhitekturom. U stvari, čak i kod dobro informiranih ljudi moderna je često opisana kao funkcionalistička, a to je kompletno krivo” (Richards)*
- *“moderna i funkcionalizam nisu sinonimi” (Schulitz)*
- *“moderno u izgledu-tradicionalno u organizaciji” (Wittic)*

Dining & Kitchen



Food



Health & Beauty



Decoration Souvenirs, Paintings Photos Flowers

Cloths Shoes Umbrellas

TV computer printer

Dress

Furniture

CD Books Papers

Accounts Documents

Toys

Equipments

Tools

Maintenance

Cleaning

Toyo Ito: Sister's House



Robert Venturi: Own House



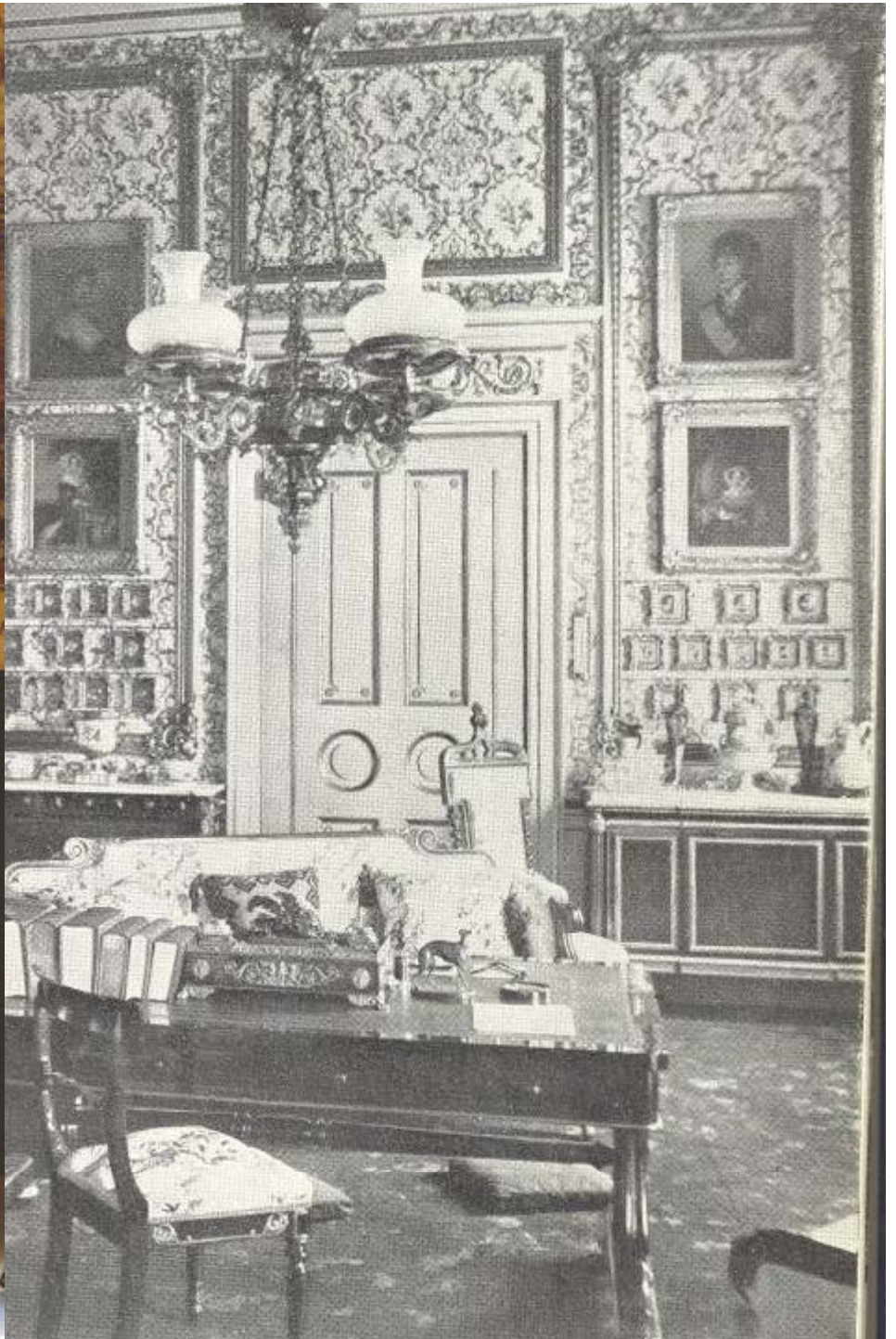
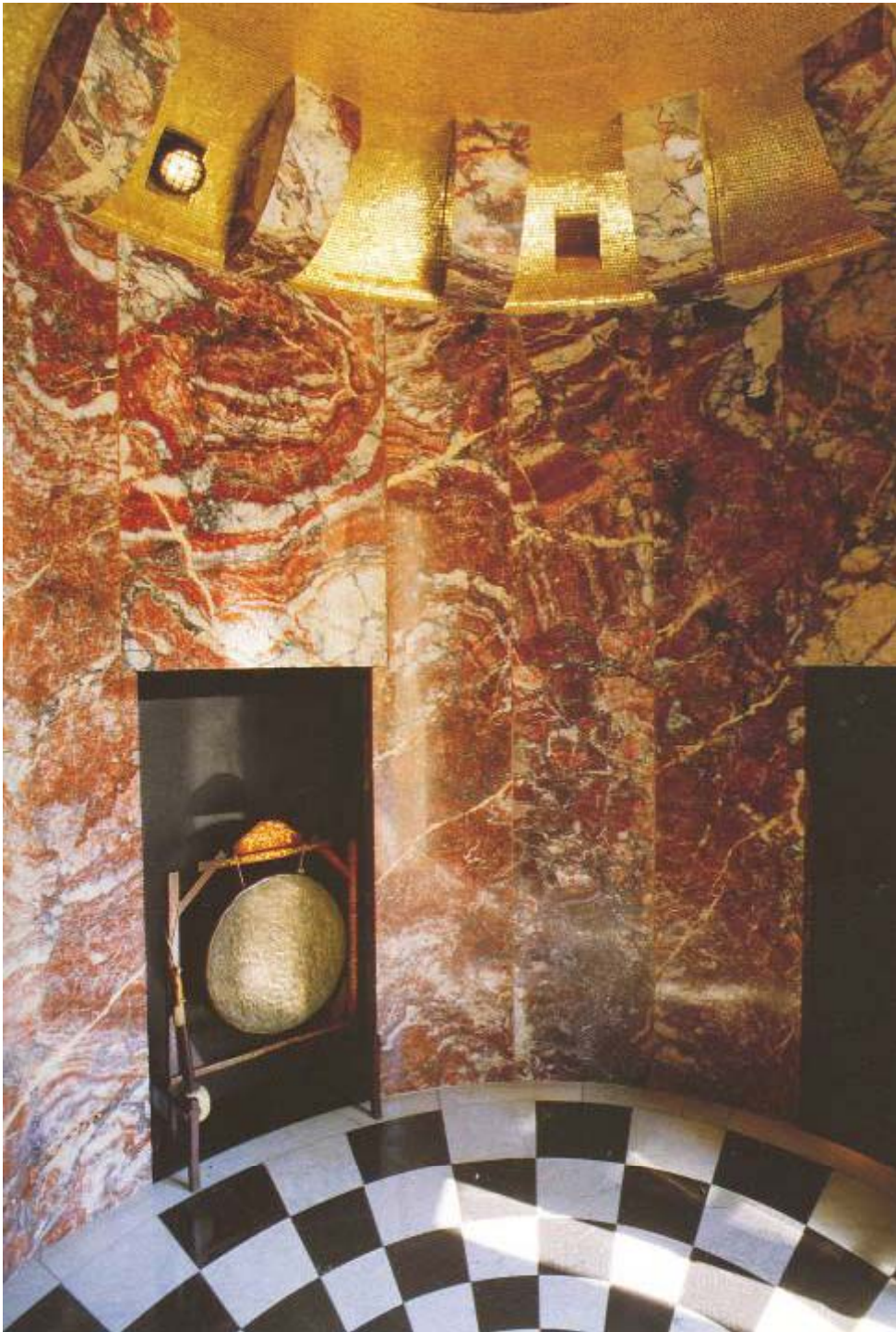

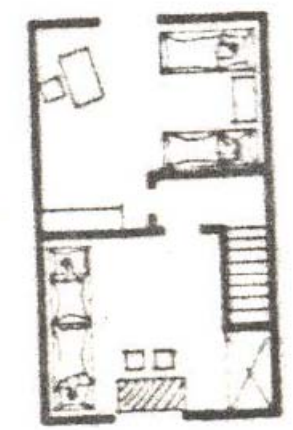

Oberg.

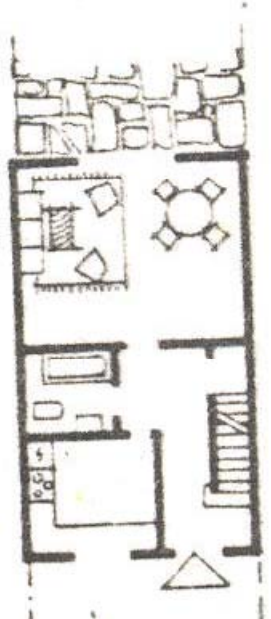

Erdg.

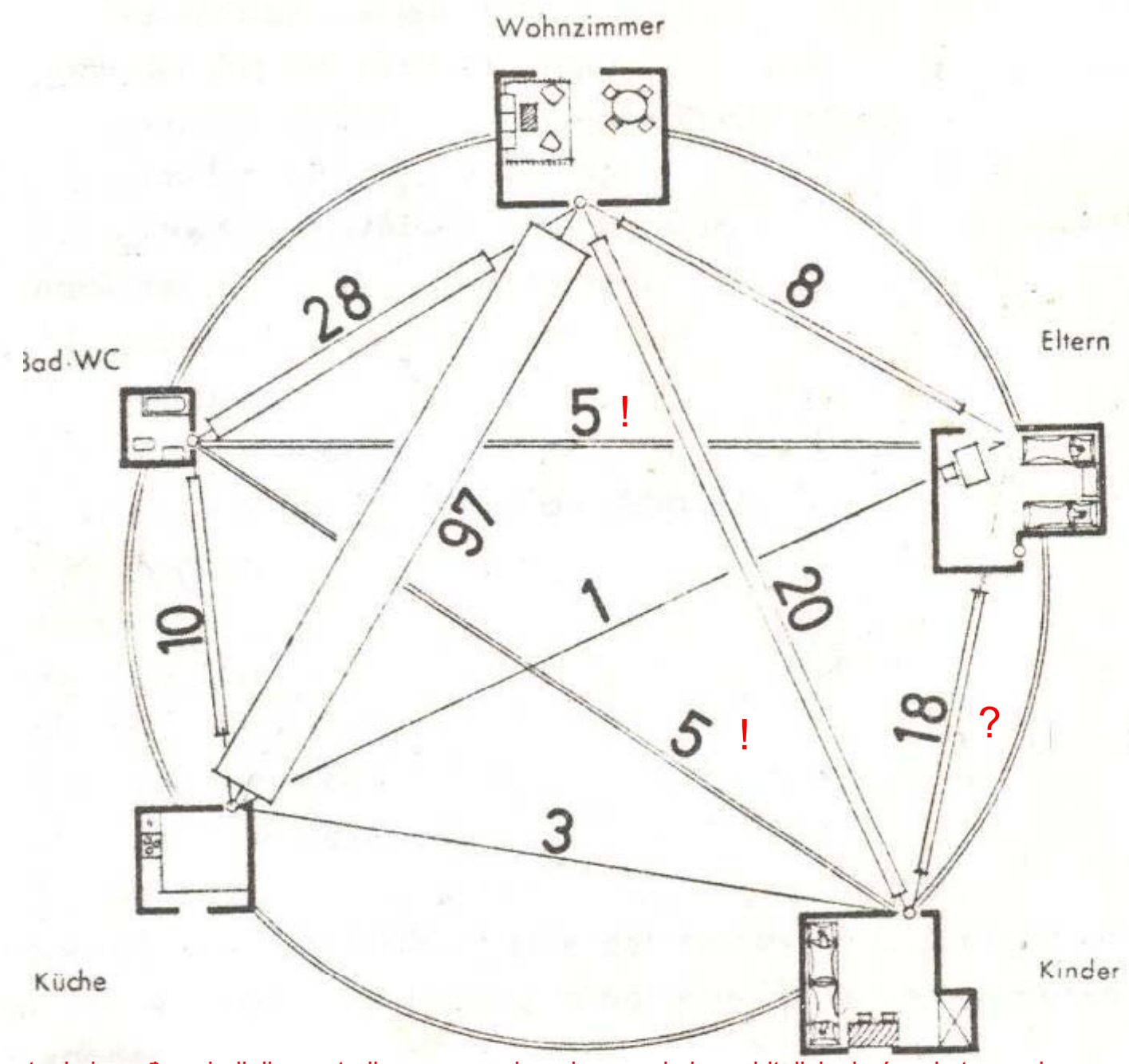

Intezitet kretanja između pojedinih prostorija prema mjerenju na primjeru obiteljske kuće u katnom nizu:

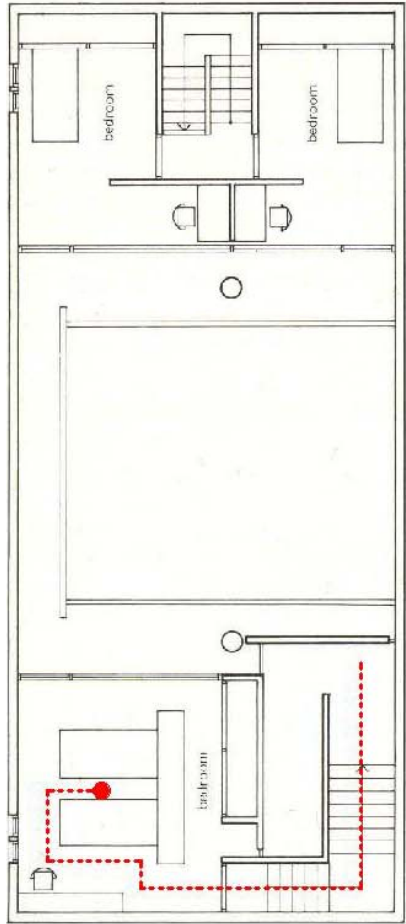

Second-floor plan.

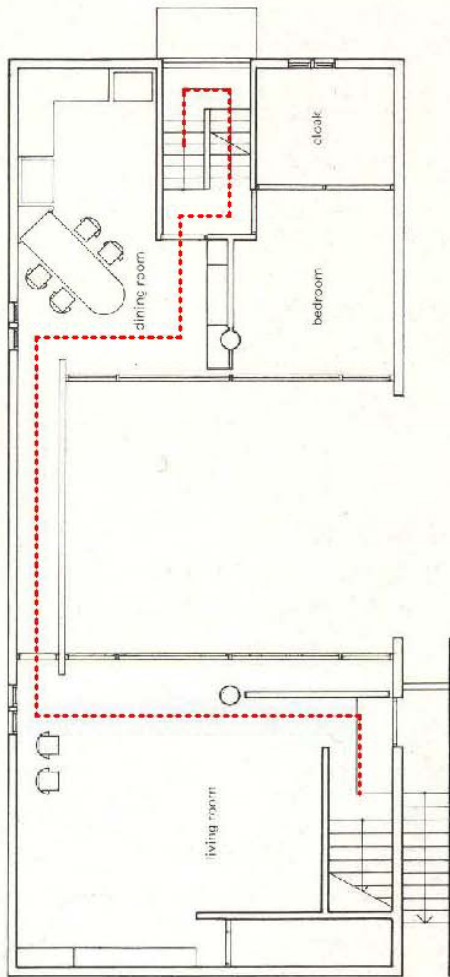

First-floor plan.

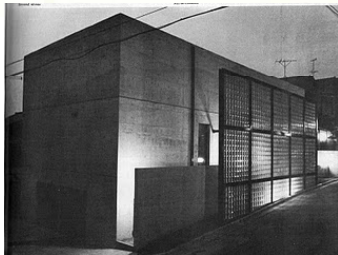
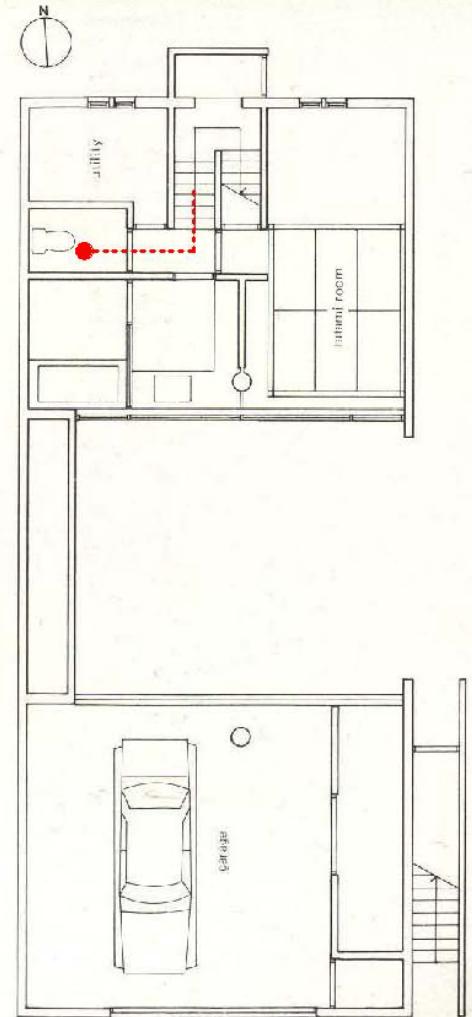

Tadao Ando: kuća Horiuchi, 1979.

Bela Auer: vlastita kuća, 1929.

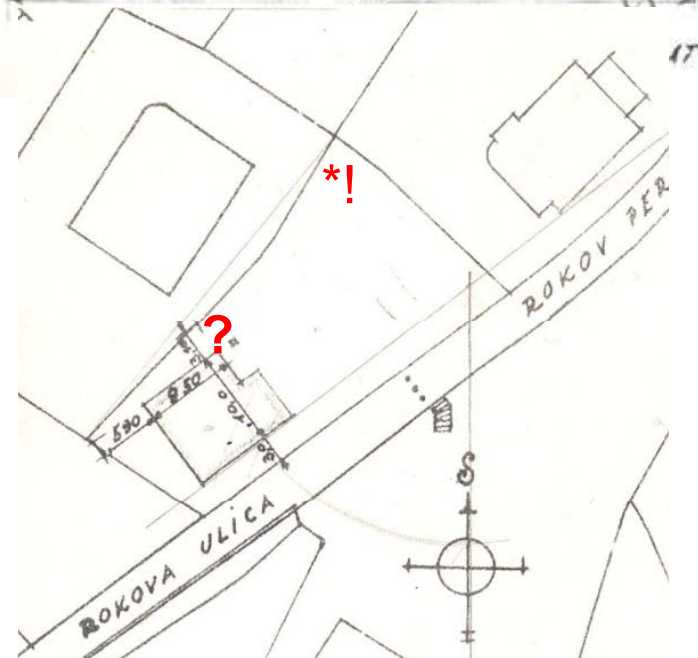
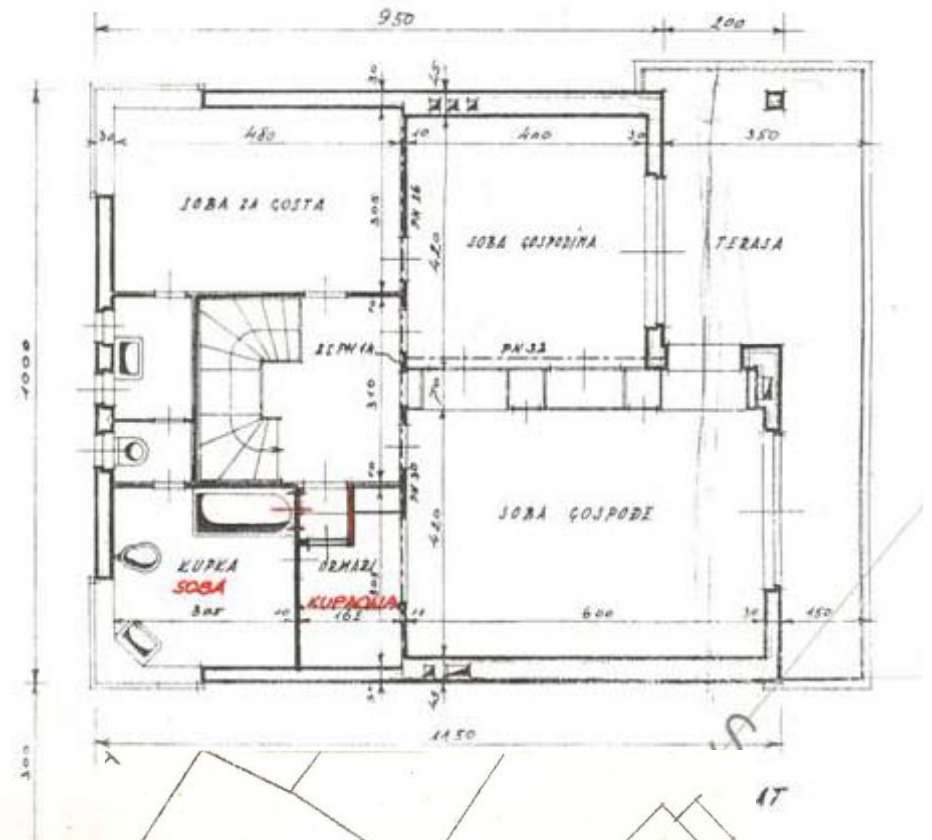
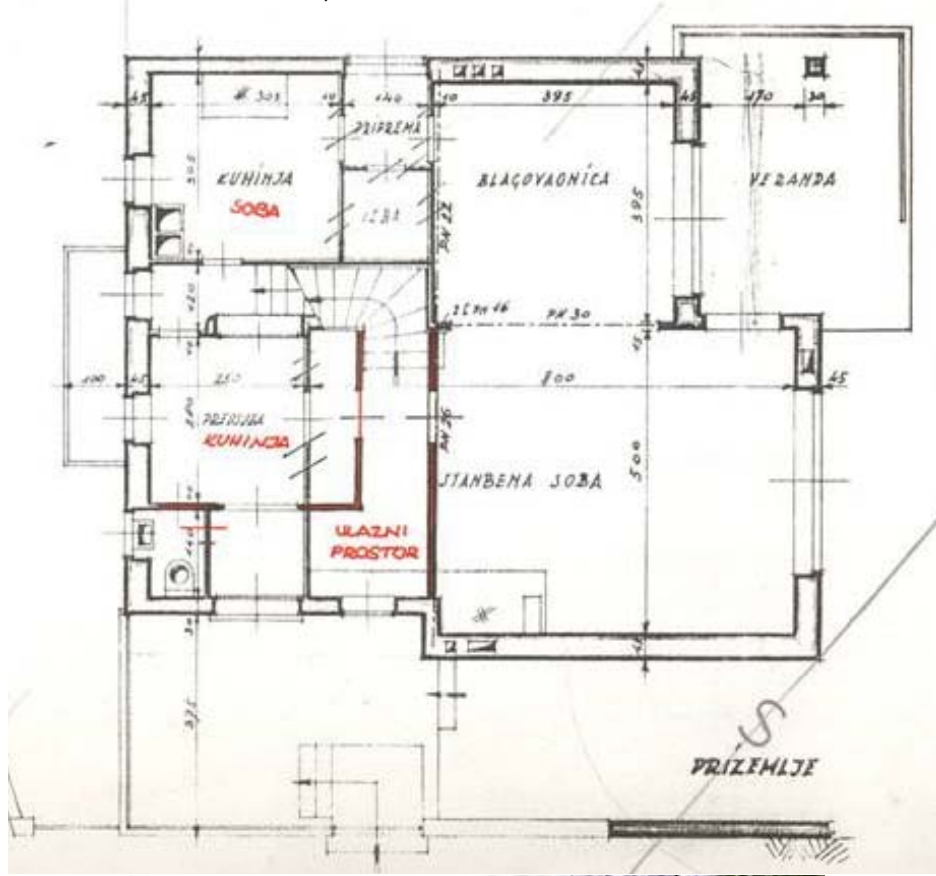



living room-dining room-study
 avangardno moderan interijer = !
 (funkcionalnost)/racionalnost = ?
 P= cca 200 m²

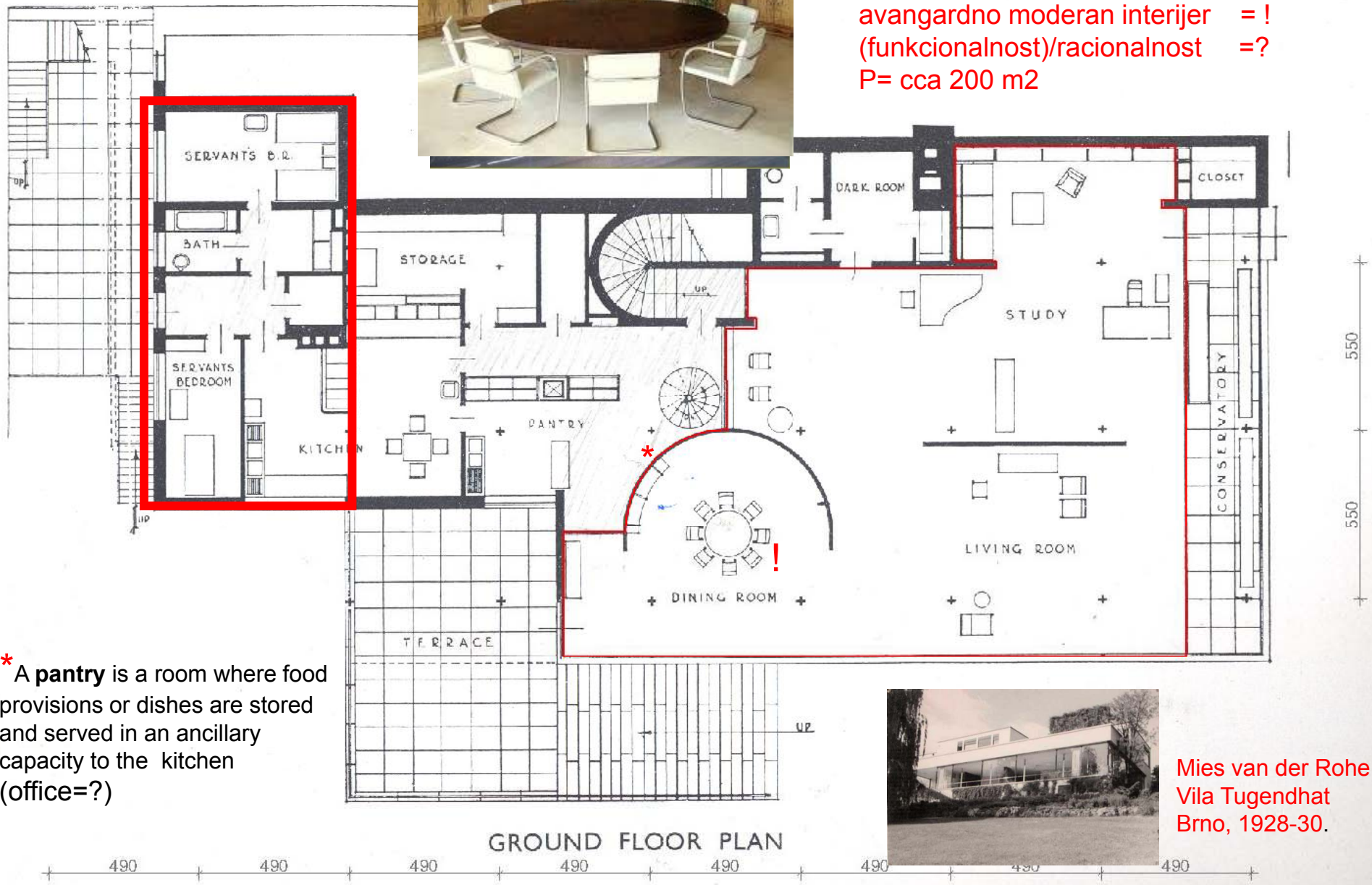

* A **pantry** is a room where food provisions or dishes are stored and served in an ancillary capacity to the kitchen (office=?)



Mies van der Rohe
 Vila Tugendhat
 Brno, 1928-30.



Walter Gropius, (1919.-'28.)



Hannes Meyer, (1928.-'29.)



Mies Van Der Rohe, (1929.-'33.)



Wassily Kandinsky



Marcel Breuer, Isse&Walter Gropius



Paul Klee

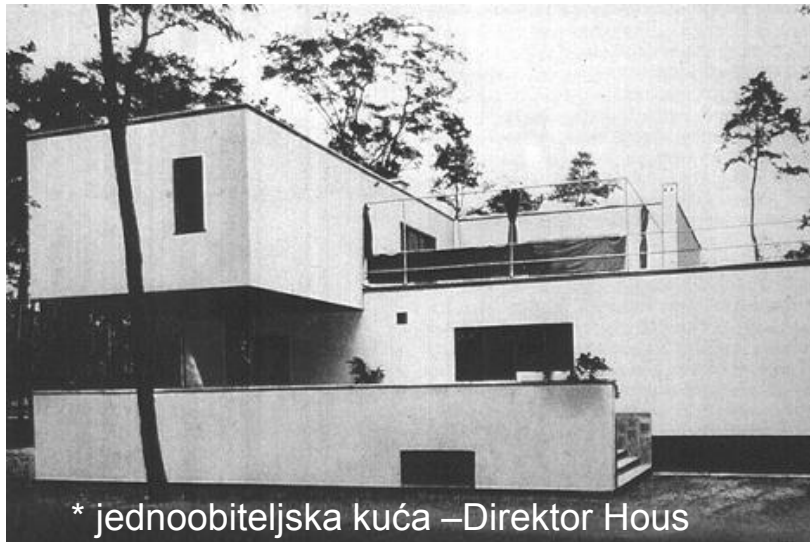

**Walter Gropius : Masters' Houses,
Dessau, 1925-26**

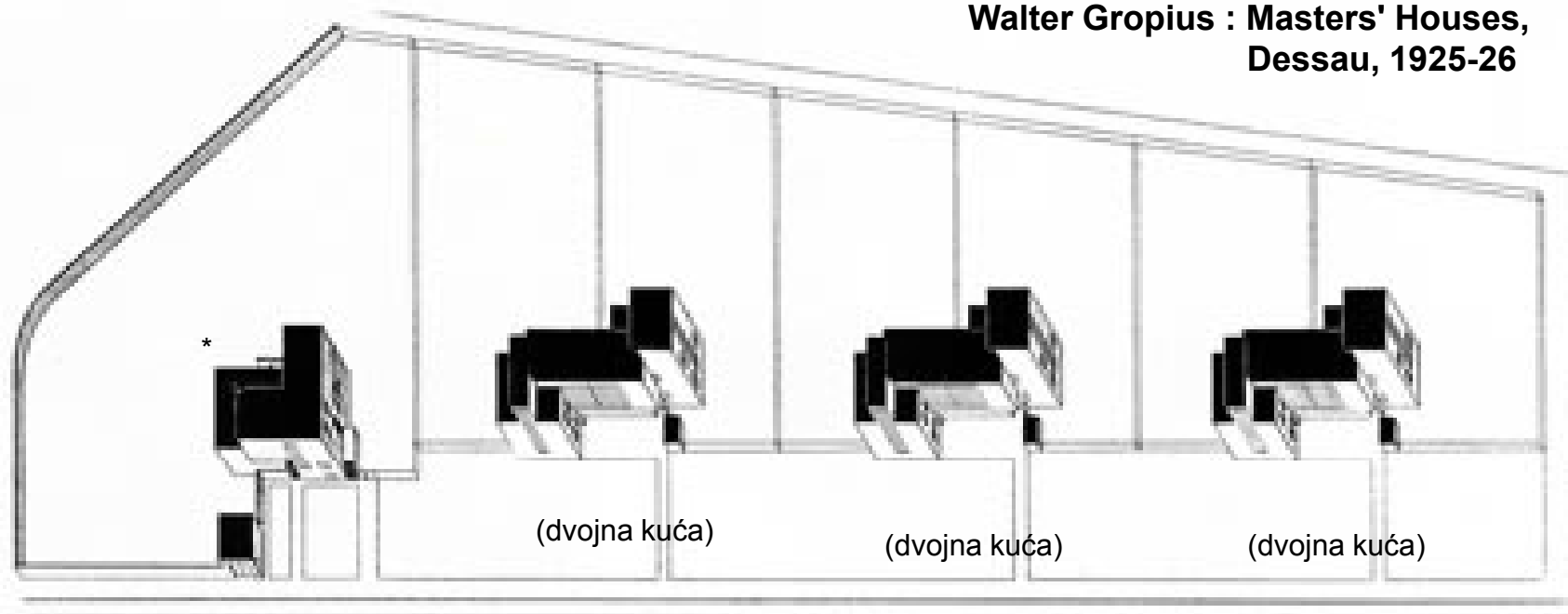

**BAUHAUS –simbol funkcionalizma je ustvari veliki promotor modernizma
BAUHAUS – stvara i podržava mit da je moderna arhitektura funkcionalna**



dvojne kuće za nastavnike, Bauhaus, Dessau 1926.
(devastirane i obnavljane od 1992.)



Bauhaus, 1919.-1933.



Wassily Kandinsky, 1866.-1944.



kuće za nastavnike,
Bauhaus, Dessau 1926.



- imenovanje prostorija SOBA sadržajnim nazivima je početak funkcionalizma (1)
- crtanje namještaja u pojedinim funkcionalnim prostorijama je razvijanje funkcionalizma (2)
- označivanje sjever-a i uvažavanje strana svijeta je daljnji razvoj funkcionalizma (3)

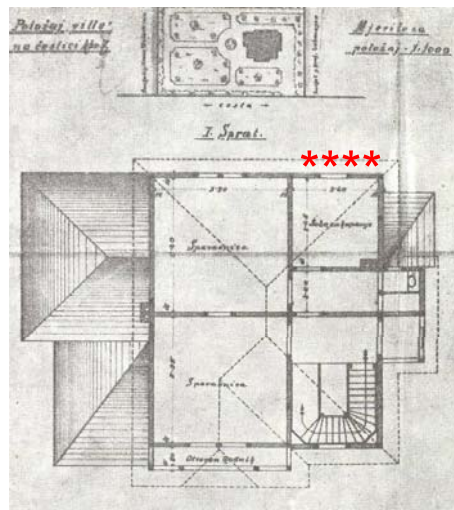
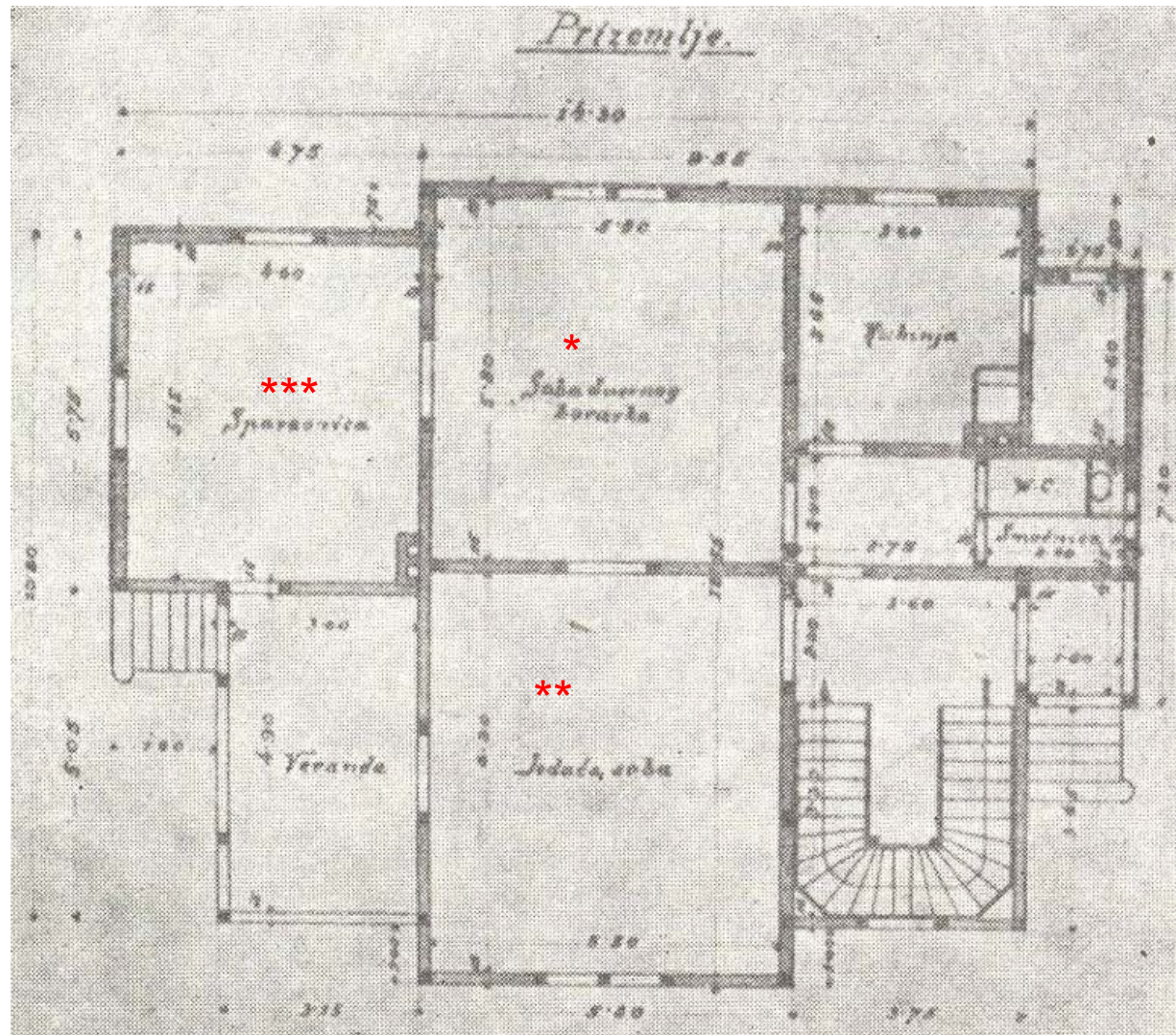
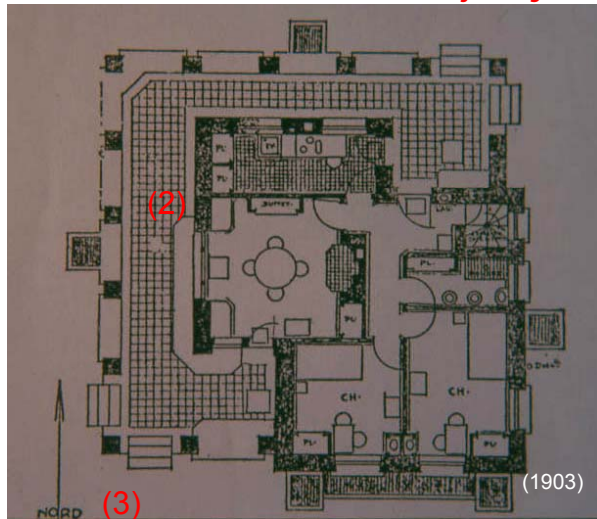

SOBA (1) – *soba dnevnog boravka** – *jedaća soba***, blagovaonica- spavaća soba, *spavaonica* ***
 – *soba za kupanje***** ,kupaonica -WC _ *kuhinja- smočnica*

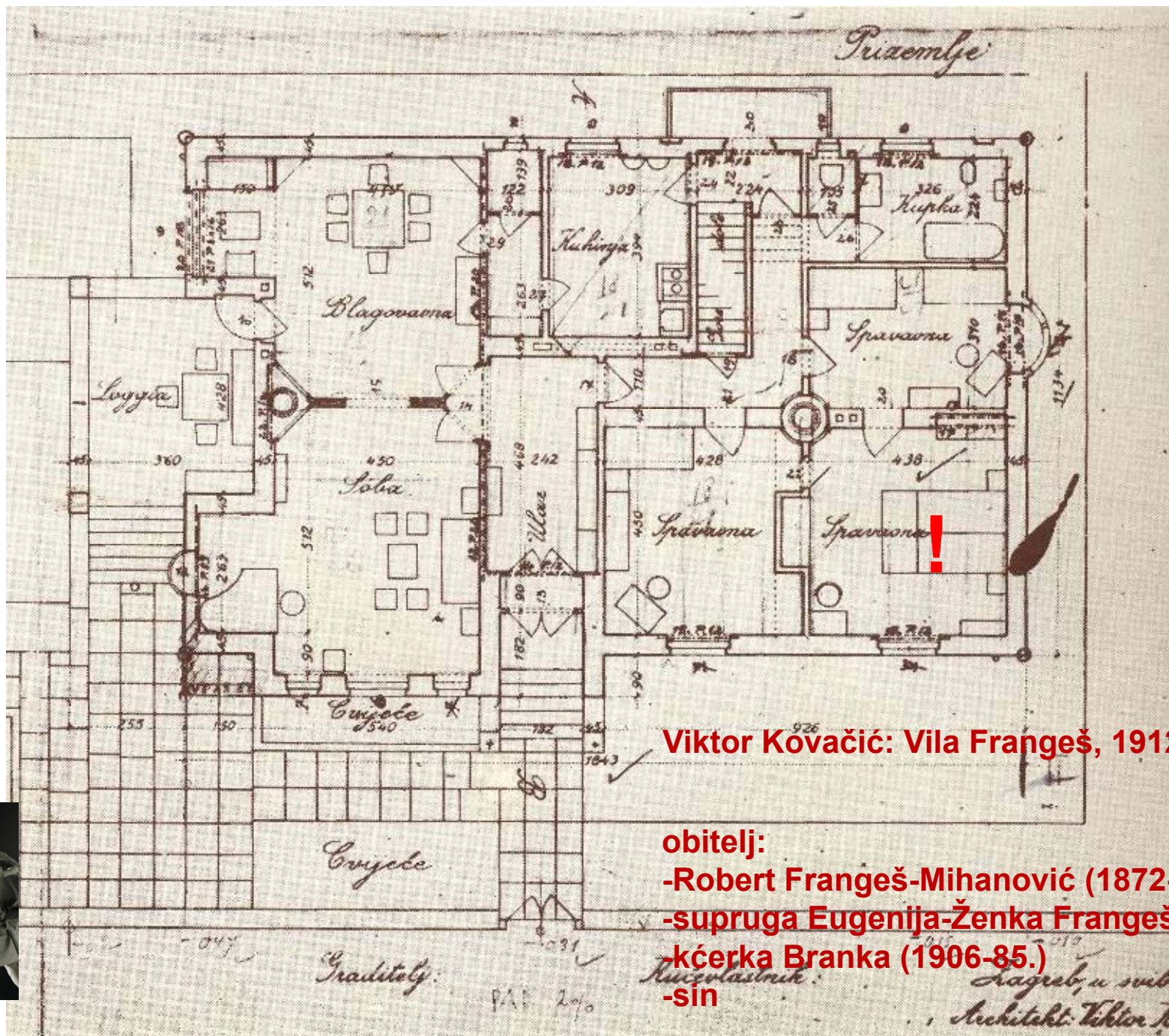

Viktor Kovačić: Vila Frangeš, 1912.

obitelj:

-Robert Frangeš-Mihanović (1872-1940)

-supruga Eugenija-Ženka Frangeš

-kćerka Branka (1906-85.)

-sin



*zagreb, u svibnju
Arhitekt: Viktor K.*

and constructed of heavy brickwork and concrete. Also, perhaps for the first time in American architecture, the Robie House boasts an integral garage.* Nicknamed the

1906. – 1908.



Ford assembly line –(1908)-1913

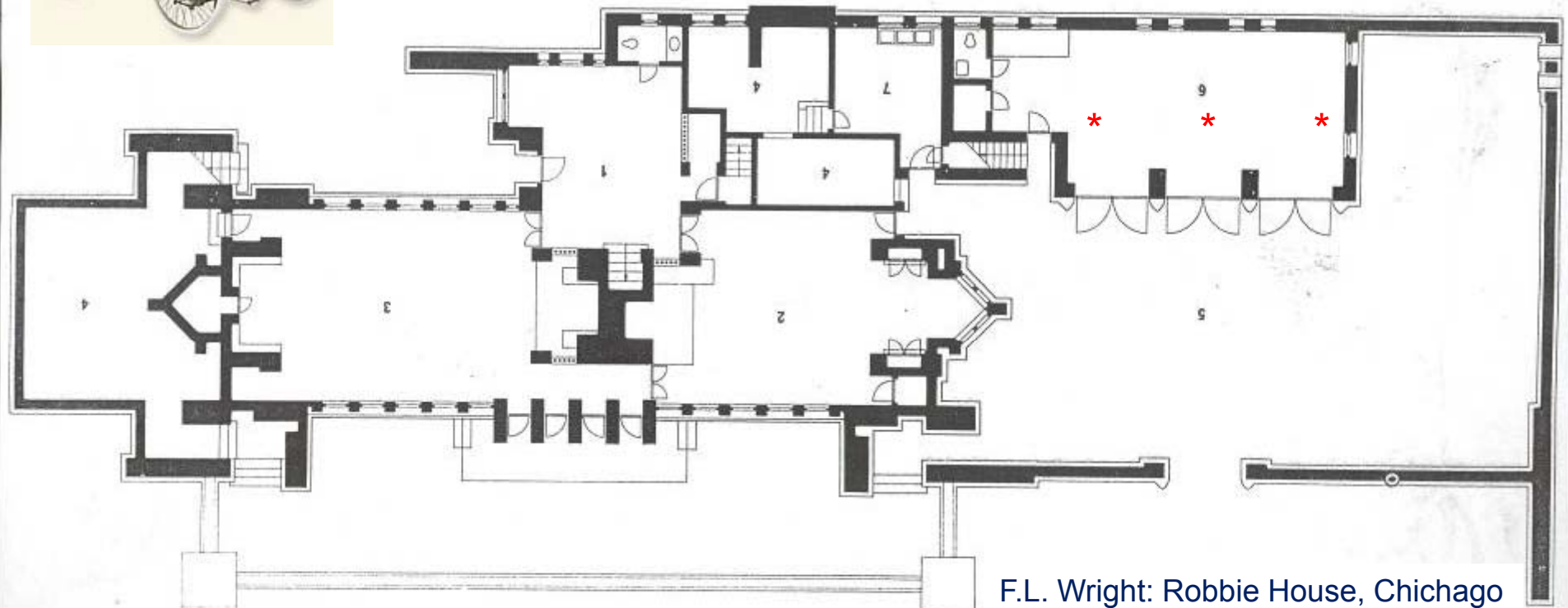

F.L. Wright: Robie House, Chicago

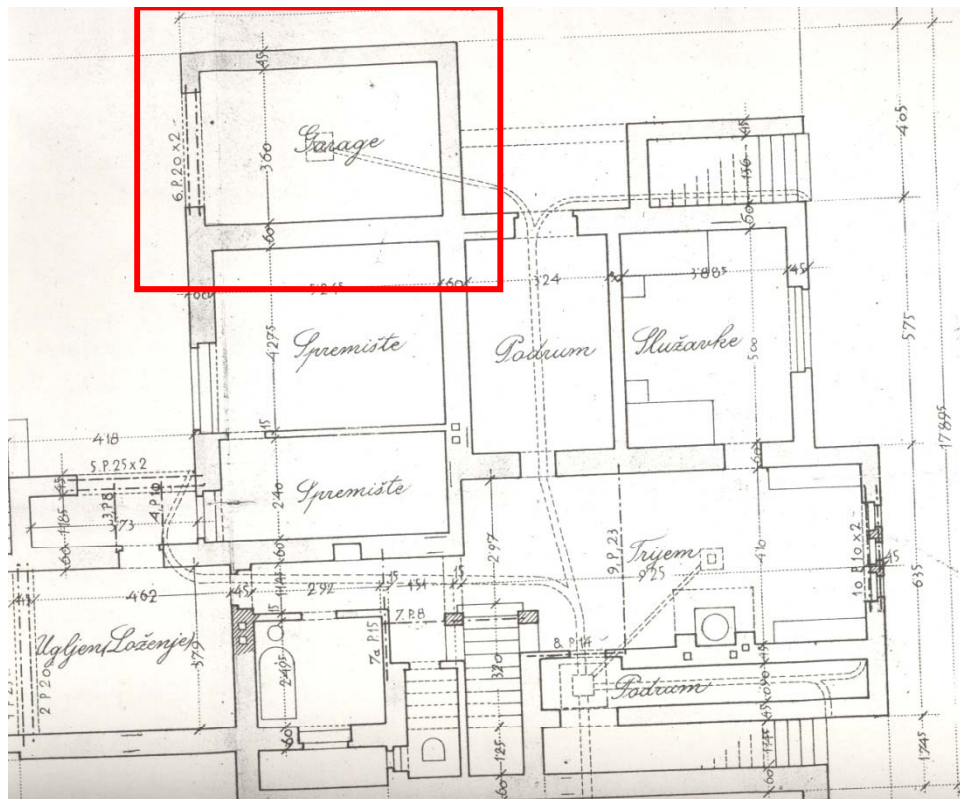

1901. – prvi automobil
na ulici u Zagrebu (Budicki)

Viktor Kovačić:
Vila Vrbančić, 1911-12.
/prva(?) zagrebačka garaža unutar obiteljske kuće

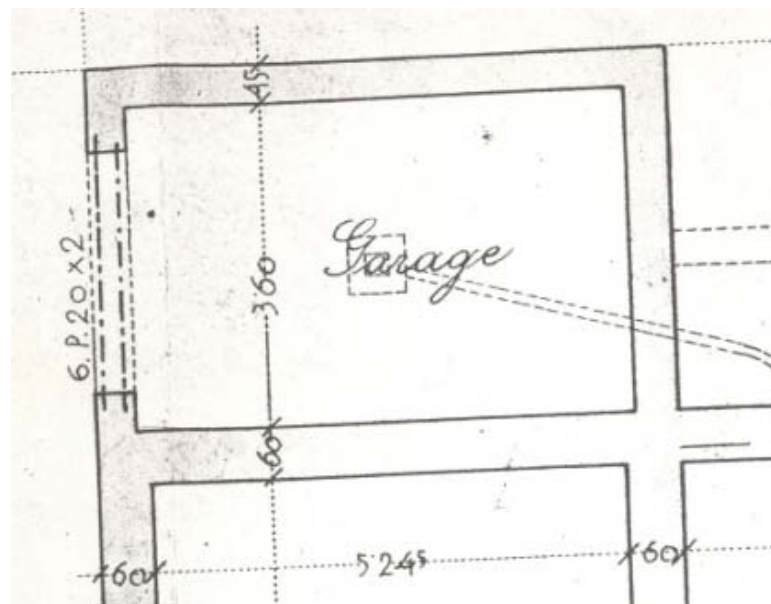

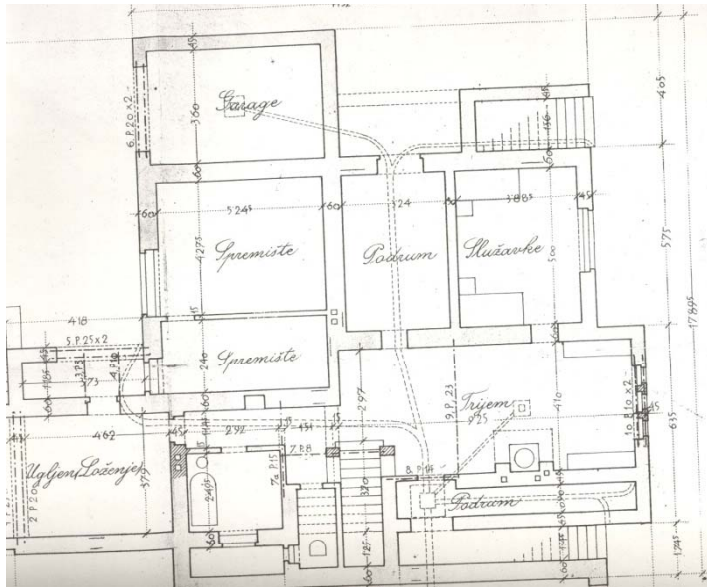

| | Deutschland | USA |
|----------------------|-------------|--------|
| Kartoffeln - krumpir | 158 kg | 46 kg |
| Vollmilch - mlijeko | 126 l. | 158 l. |
| Gemüse - povrće | 45 kg | 104 kg |
| Obst - voće | 69 kg | 88 kg |
| Fleisch - meso | 46 kg | 84 kg |

Über den Verbrauch an Heizöl sind folgende Zahlen bekannt:
 o potrošnji lož-ulja poznate su slijedeće brojke:

| Heizöl - lož-ulje | Deutschland | USA |
|-------------------|-------------|----------|
| | 50 kg | 2.500 kg |

(Podaci iz vremena prije II svjetskog rata)

služkinja, djevojka, kućna pomoćnica, *bonne*, *maid*, *servant*,



“čovjek ili ima slugu ili je sam sluga” – (Francuska, 19st.)

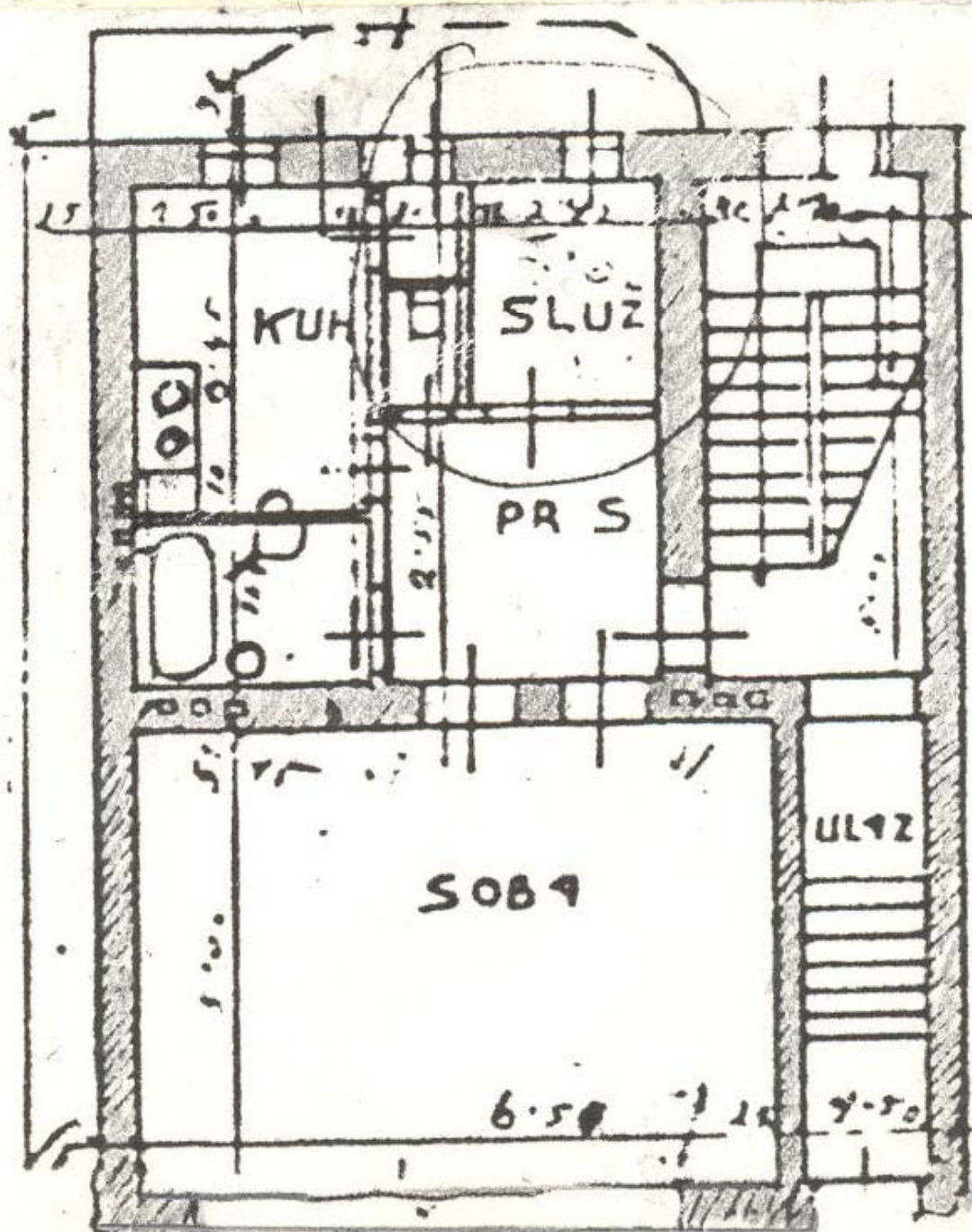

Zagreb, Naselje Kanal, 1930te

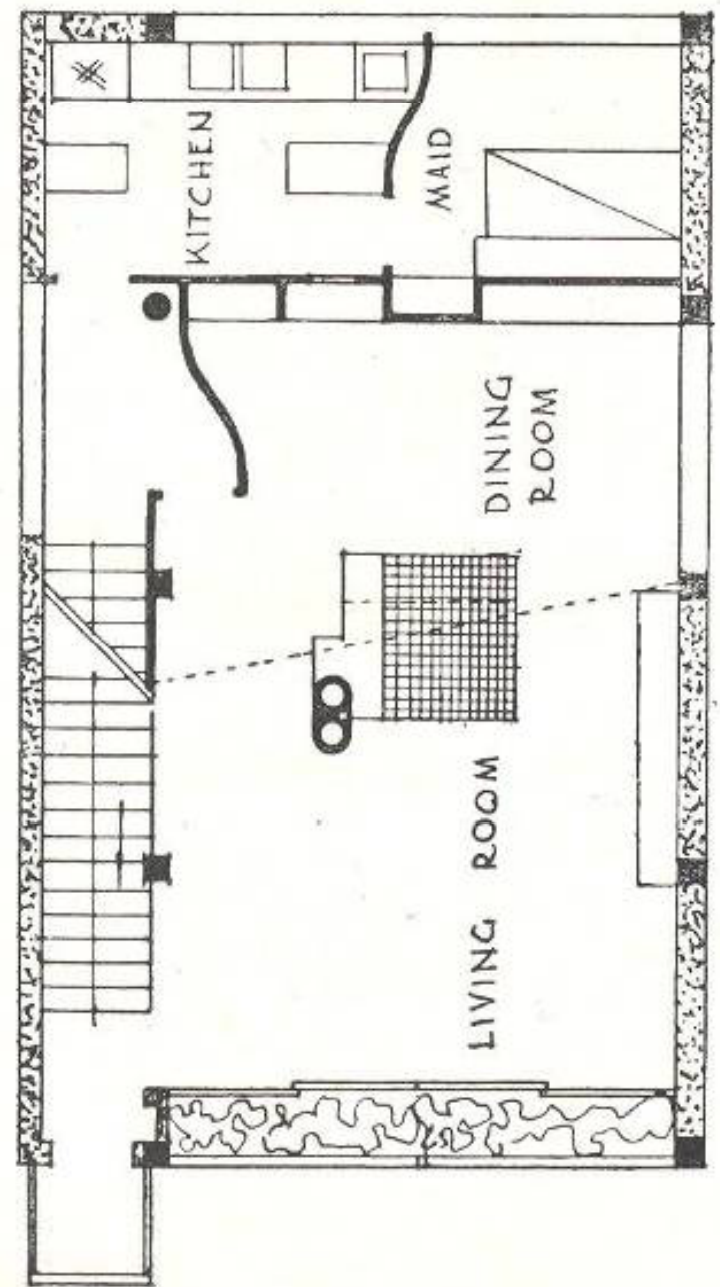

Le Corbusier: Weissenhofsiedlung, 1927.

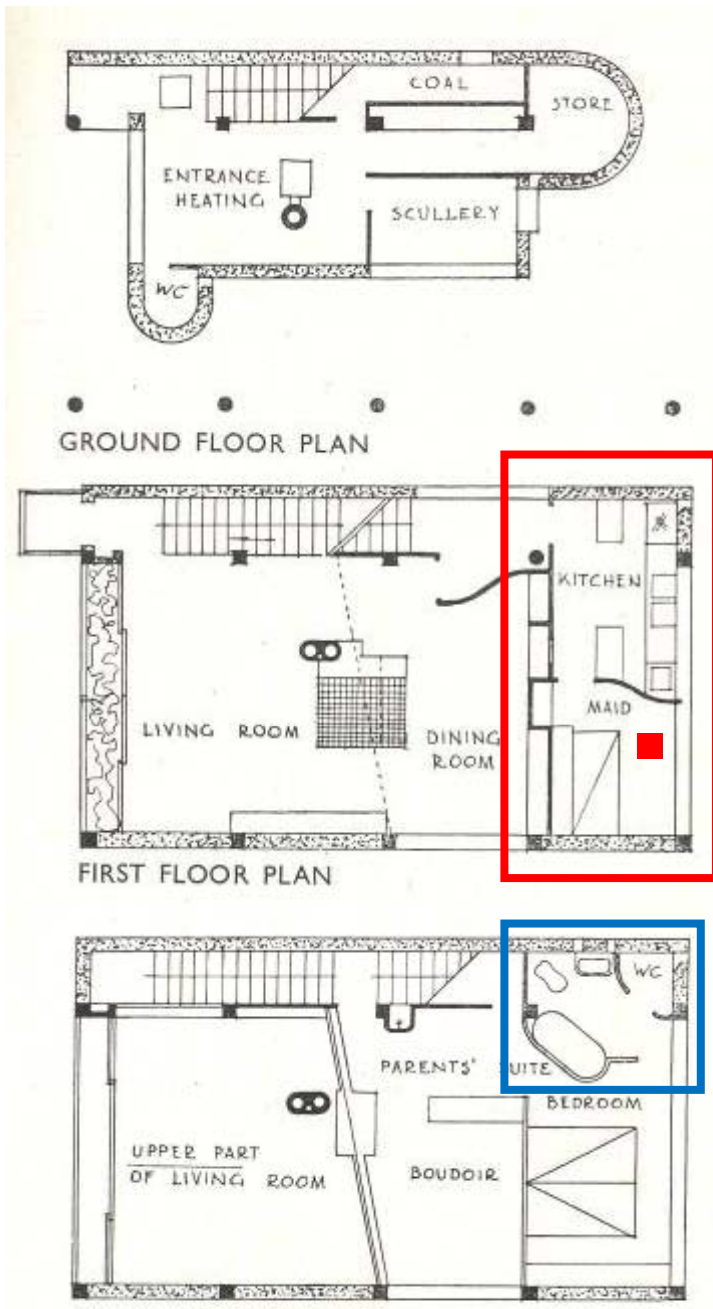

THE SINGLE HOUSE. Posts are spaced regularly, without regard to interior arrangements, so that planning is free, divisions on one floor being independent of divisions on another; posts rise directly from the ground, raising the living floor above ground dampness. These vertical posts and horizontal floors leave spaces in the façade through which light and air may penetrate freely.

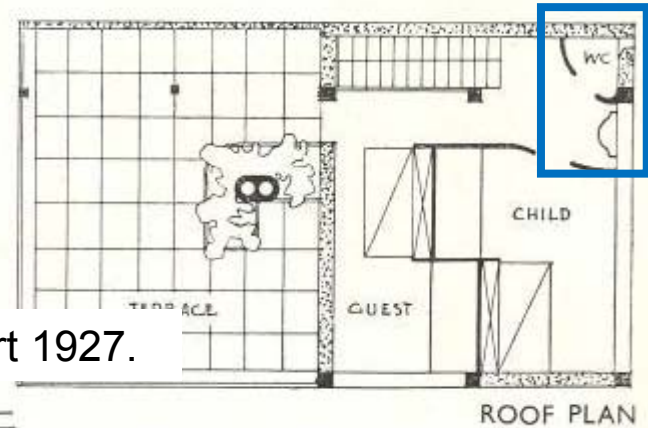

Le Corbusier: Single House, Weissenhofsiedlung, Stuttgart 1927.

3 K = Kinder, Küche, Kirche, (& Kleider) /car Wilhelm II, 1898.
(suprotno : Kaiser, Krieg, Kanonen)

"**Barefoot and pregnant**" is a phrase most commonly associated with the controversial idea that women should not work outside the home and should have many children during their reproductive years- Its usage may date as early as the 1910s.

F.L. Wright: "**vanjska profesionalna pomoć je sve što moderna domaćica treba**"

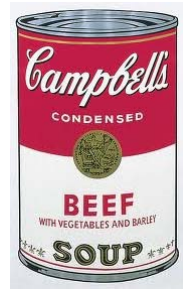

K. Galbtaith: "**početak besklasnog društva je odlazak posluge iz kuće**"

Pierre Koenig: Bailey House, L.A. 1959.



U transparentno (egalitarno) koncipiranom prostoru “kuhinje-blagovaonice–boravka” žena pokraj kuhinjske linije!

žena /supruga/ dama
u dnevnom boravku



Pierre Koenig: Bailey House,
L.A. 1959.

1596. Sir John Harrington =? (Mumford)

Water-closet (WC),

The term "water-closet" was an early term for a room with a toilet. Originally, the term "wash-down closet" was used.^[17] The "water-closet" was invented in England around 1870. It did not reach the United States until the 1880s. Around this time, only luxury hotels and wealthy people had indoor private bathrooms. By 1890, the fear of the theory of disease was beginning to arise about carelessly disposed human waste being contaminated and infectious.

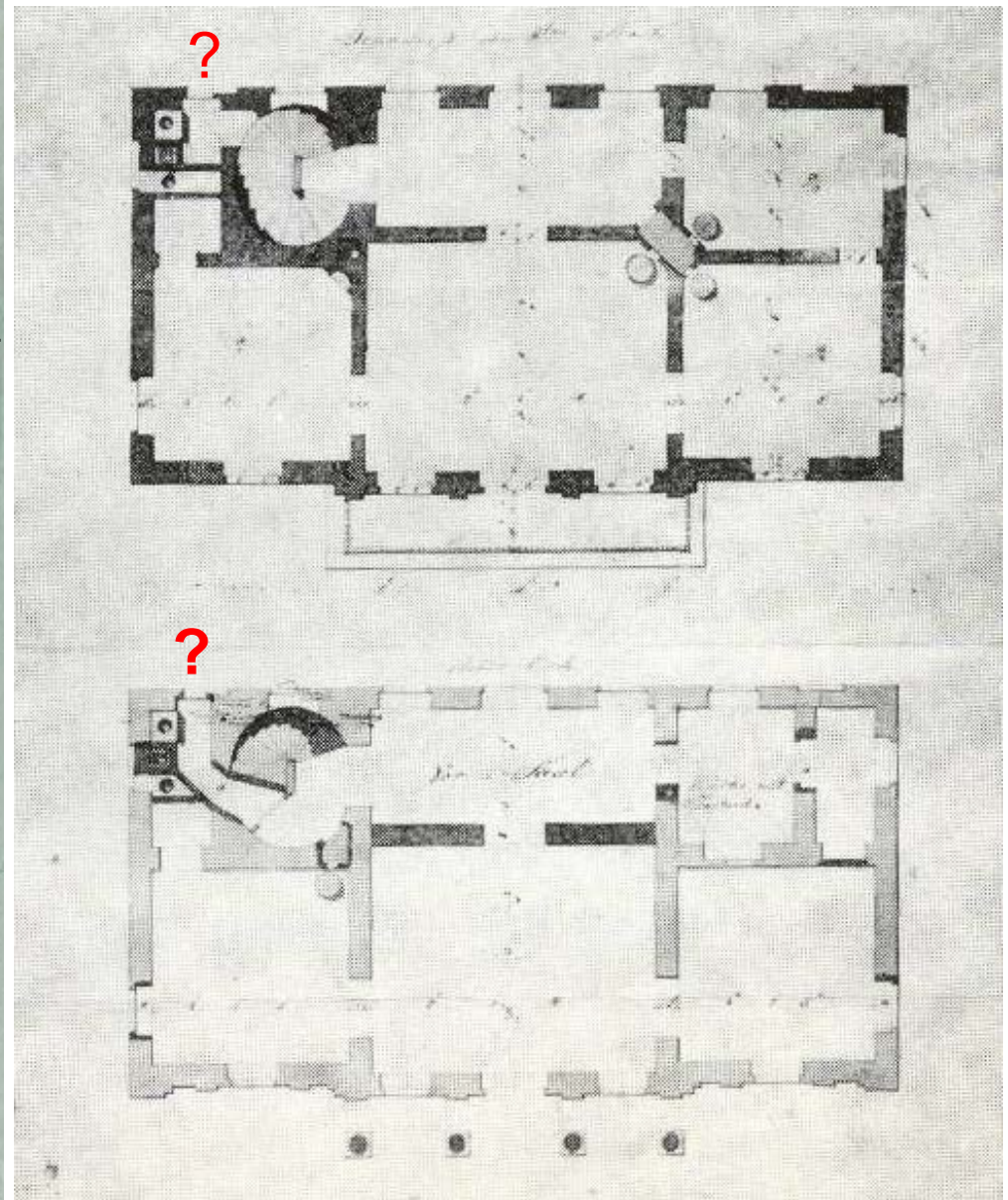
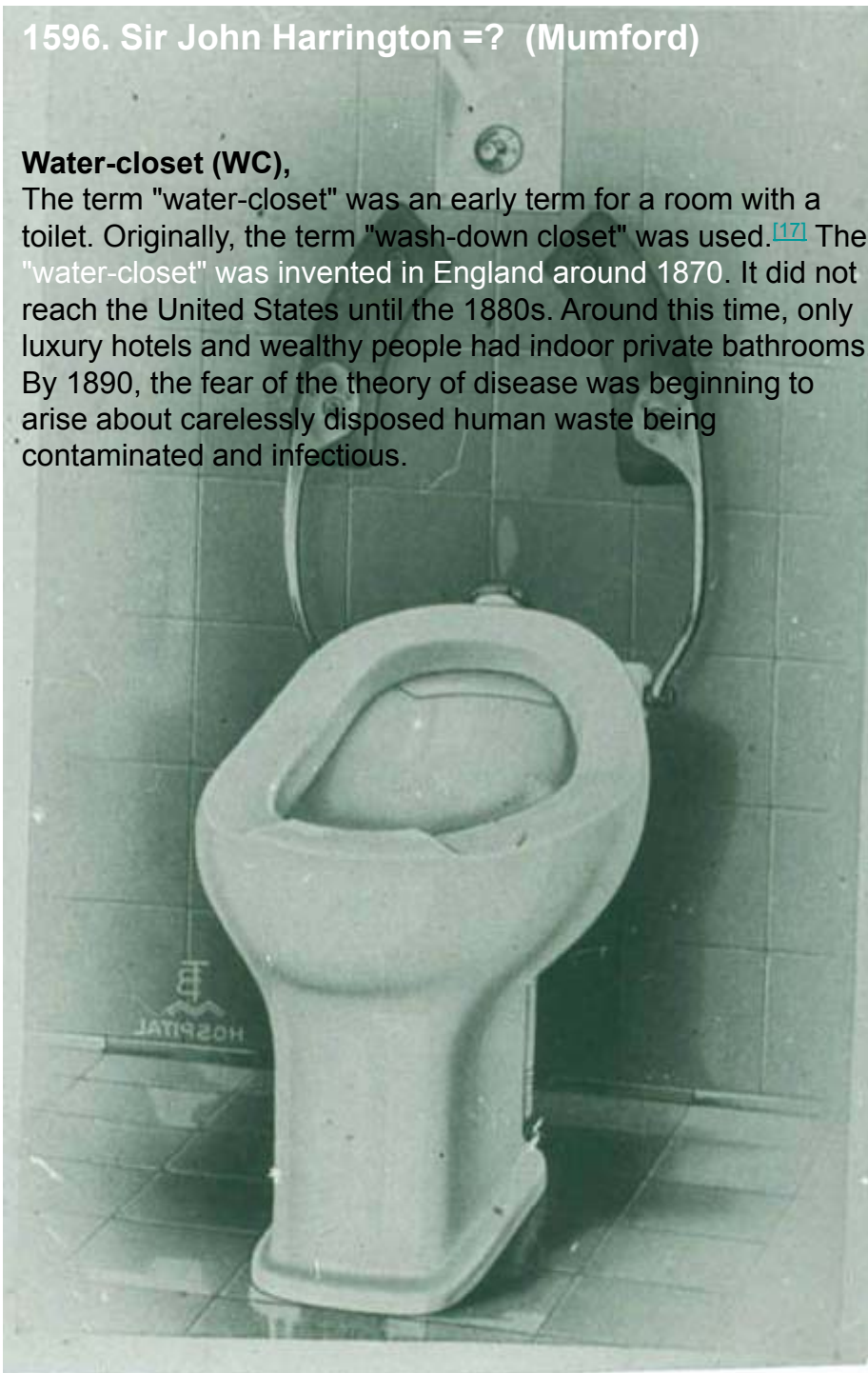

Bartol Felbinger: ljetnikovac, Nova Ves, 1823.



“U Parizu, ljudi si se kupali u javnim kupalištima ili su bili prljavi. Zbog morala, ženama nije bio dozvoljen pristup u javna kupališta. Zaprepastio se je kad je pročitao u jednoj knjizi da je Francuskinja umirala, a da se nikad nije okupala. Svi osim bogataša kupali su se samo jednom; Kupanje je bilo obavezno prije stupanja u vojsku. Ruke i noge su savjesno njegovali, ali nitko nije prao kosu. Samo su je bezdušno iščešljavali gustim nazubljenim češljem kako bi otklonili uši...” (I. Stone, 29)-vrijeme 18./19.stoljeće

Adolf Loos: "kuća se počinje projektirati od kupaonice"

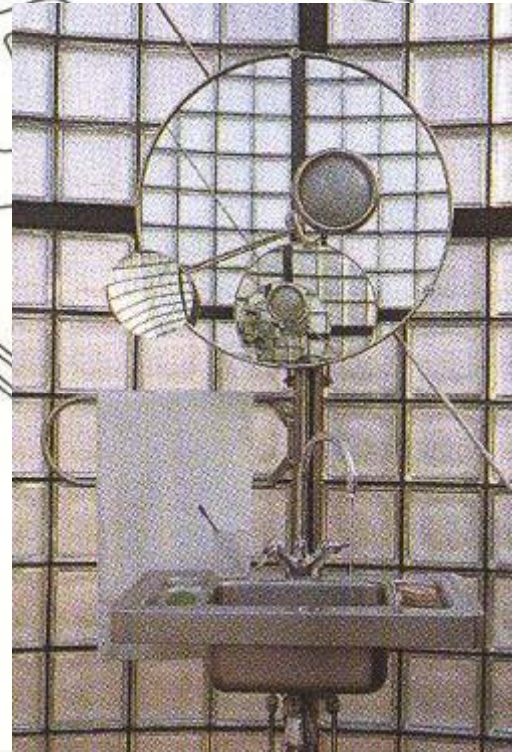

Prva moderna kupaonica - Cincinatti, 1842.

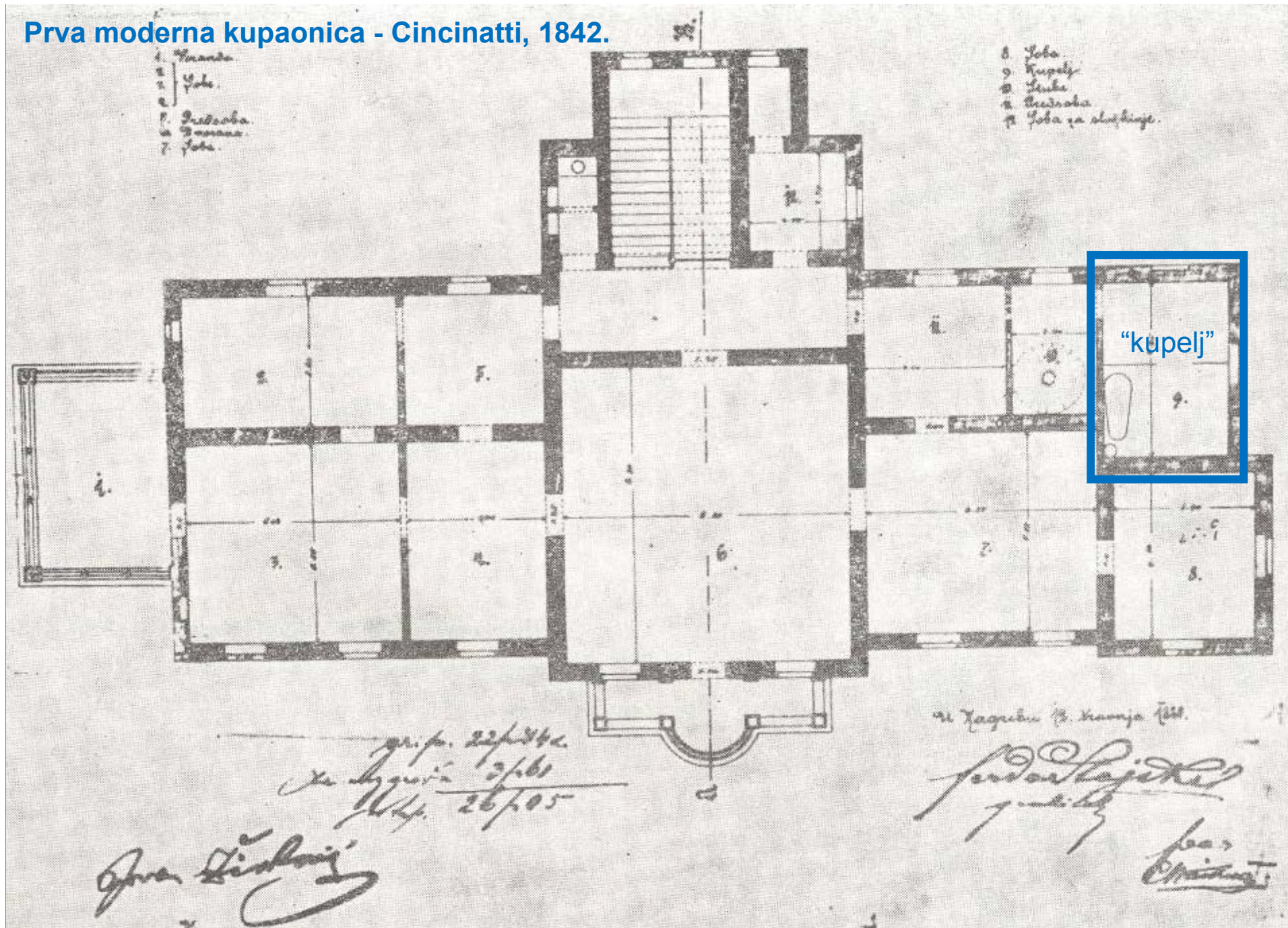

Kuno Waidmann: ljetnikovac Jovana Živkovića, Zagreb, Jurjevska 27, 1880.

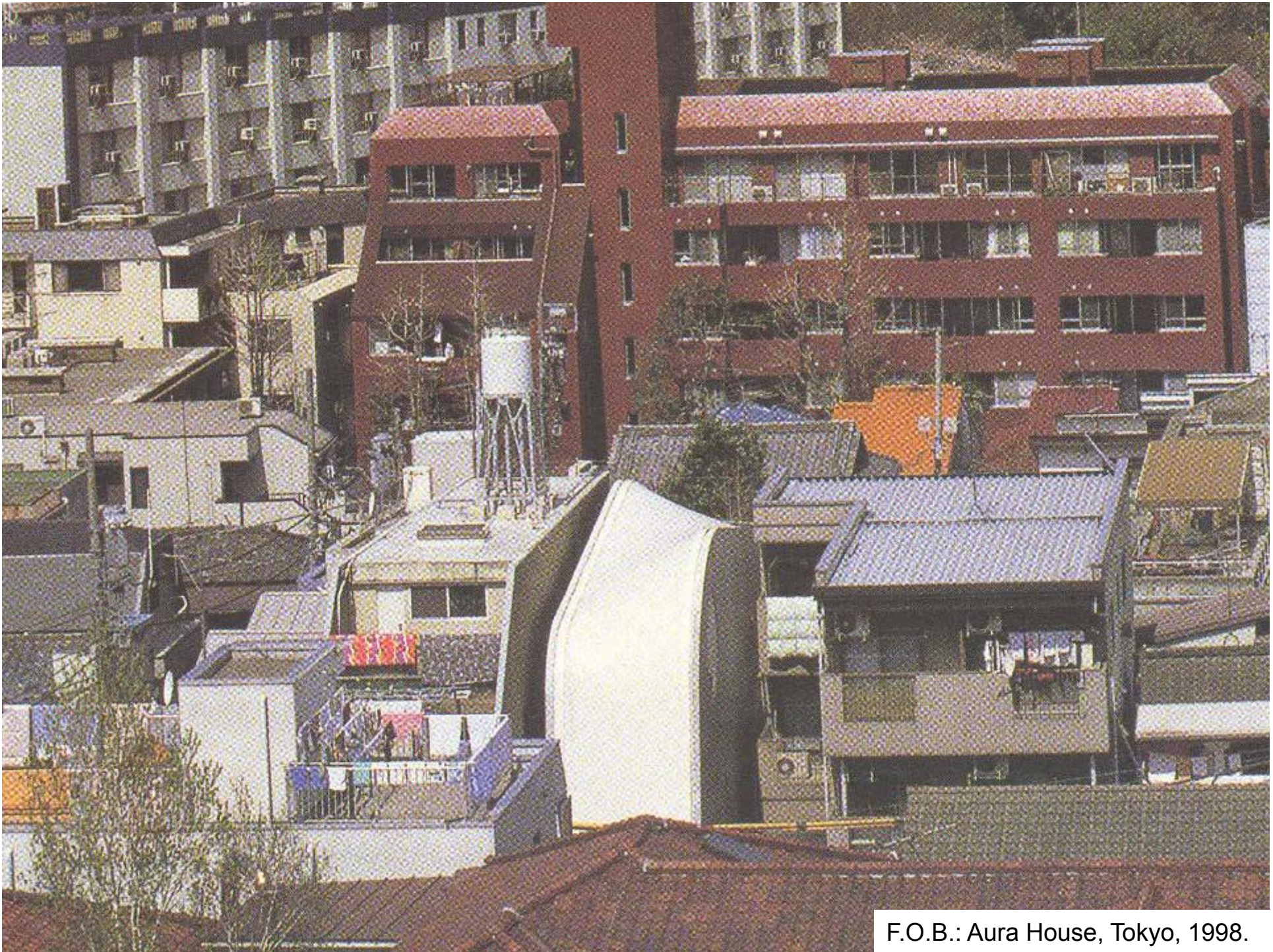

F.O.B.: Aura House, Tokyo, 1998.

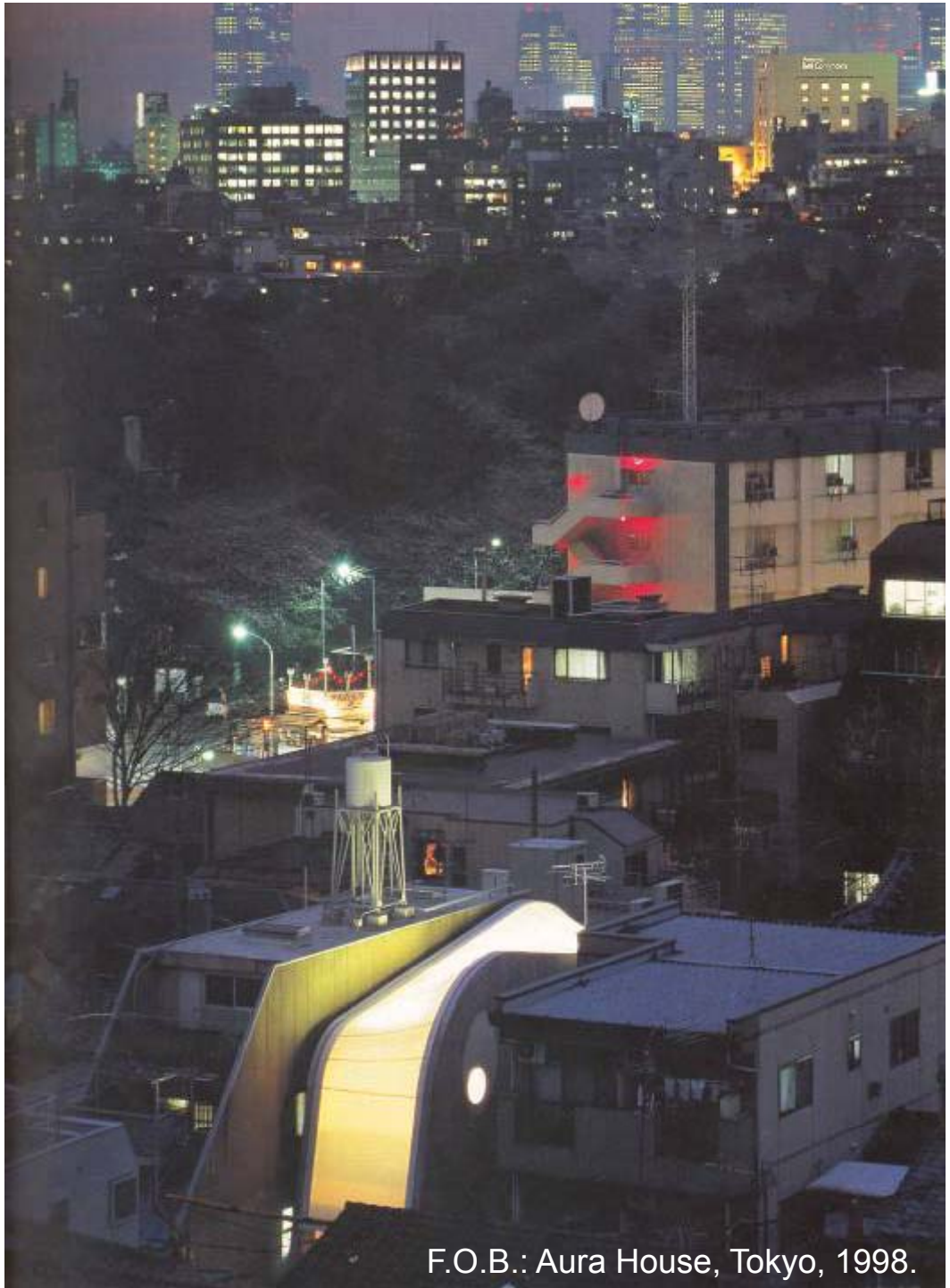
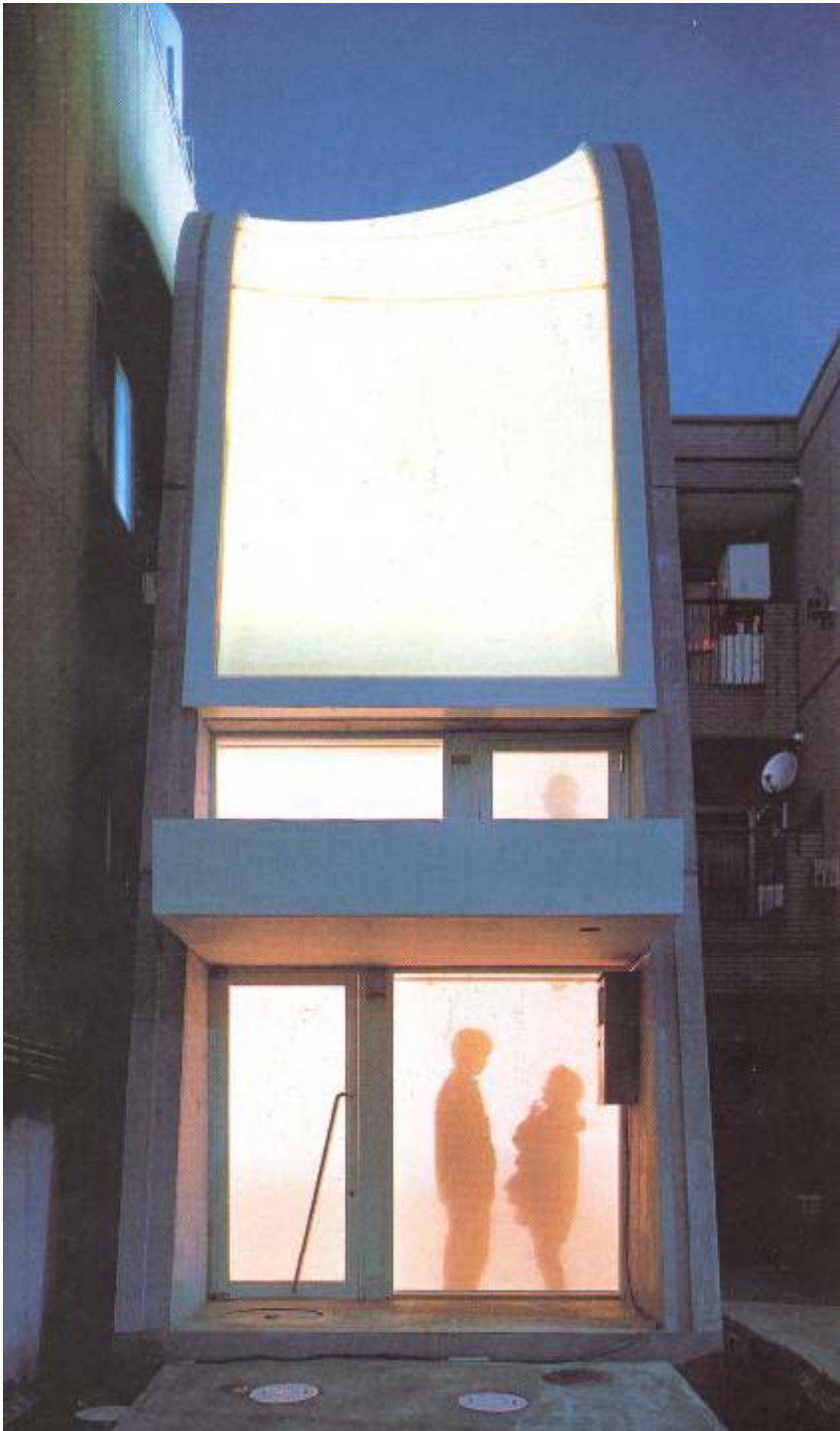

F.O.B.: Aura House, Tokyo, 1998.

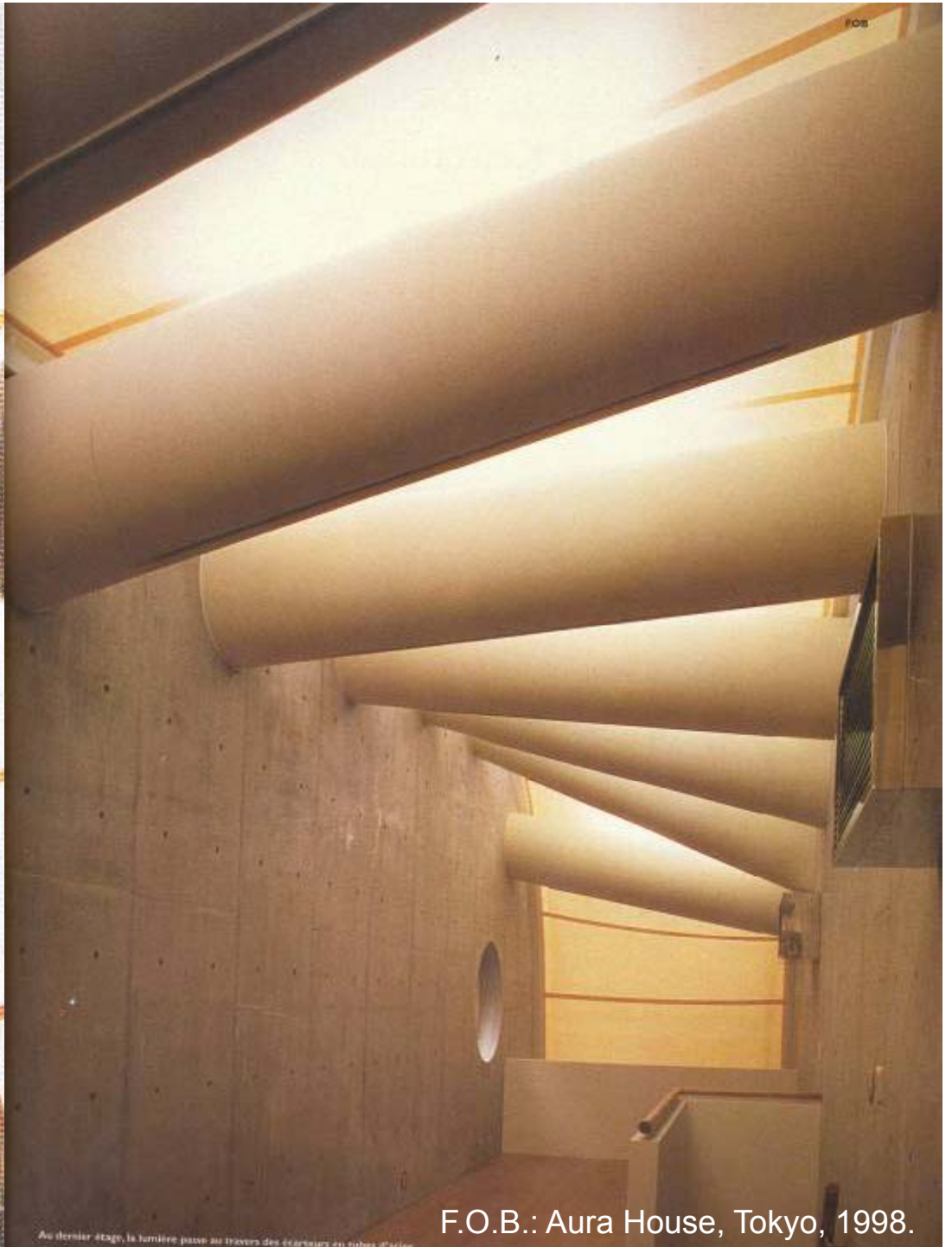
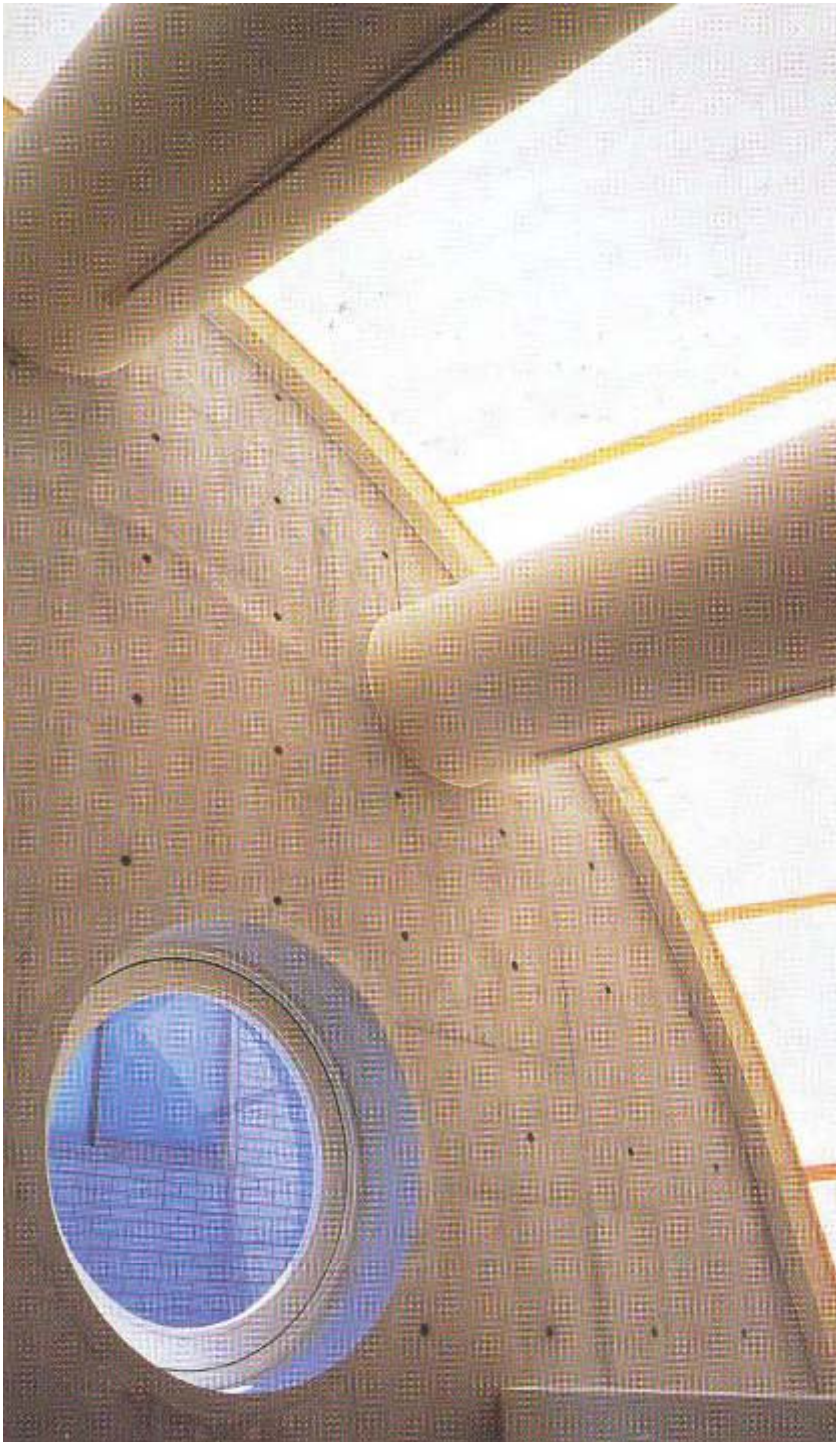

F.O.B.: Aura House, Tokyo, 1998.

Au dernier étage, la lumière passe au travers des écarteurs en tubes d'acier.

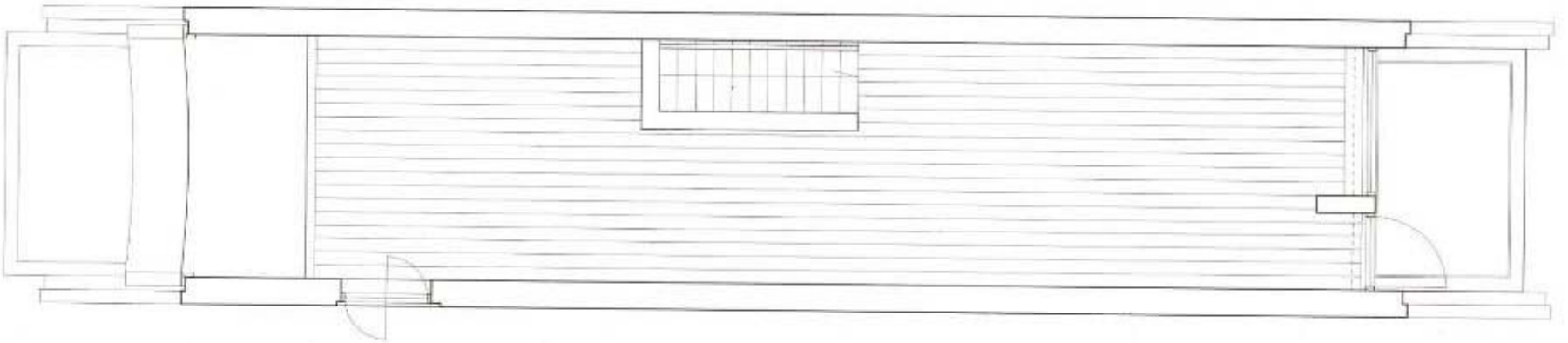
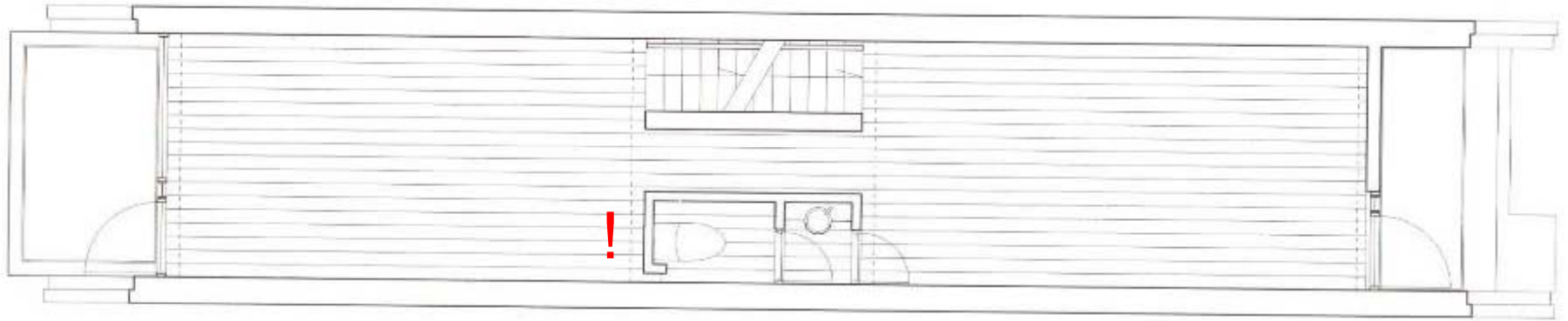
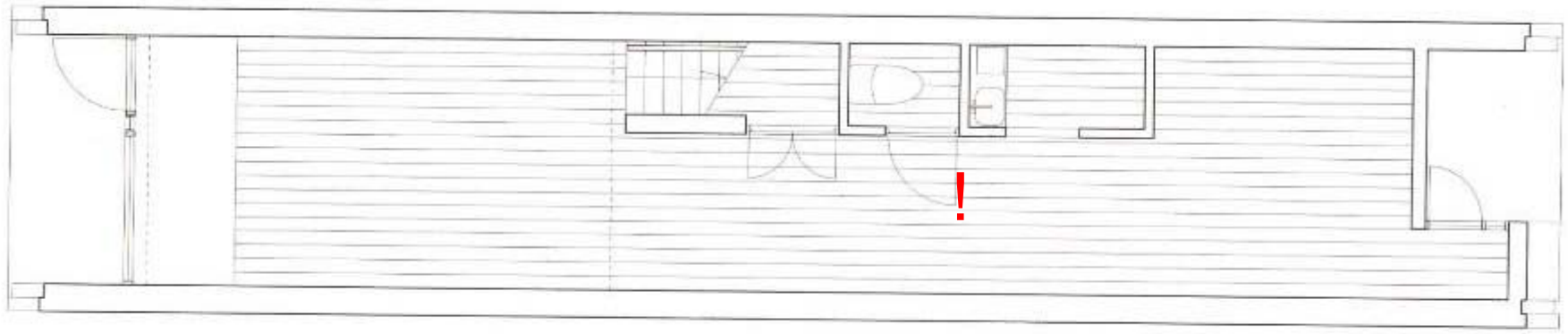

F.O.B.: Aura House, Tokyo, 1998.



CEILING

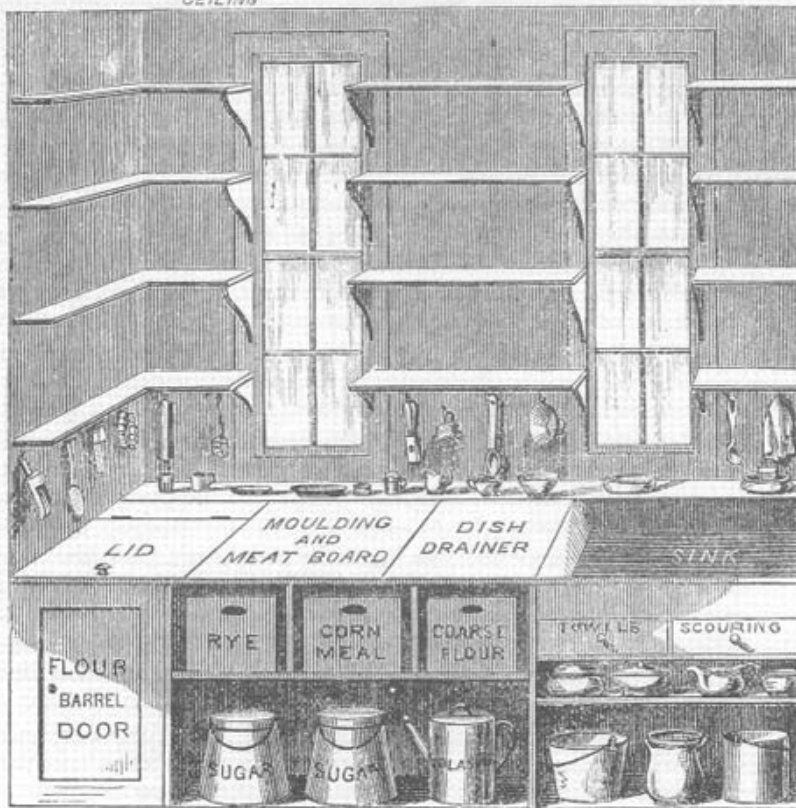

[Catharine Beecher](#) (USA) mid-19th century



Frankfurterkueche (1.9mx3.4m) 1926.

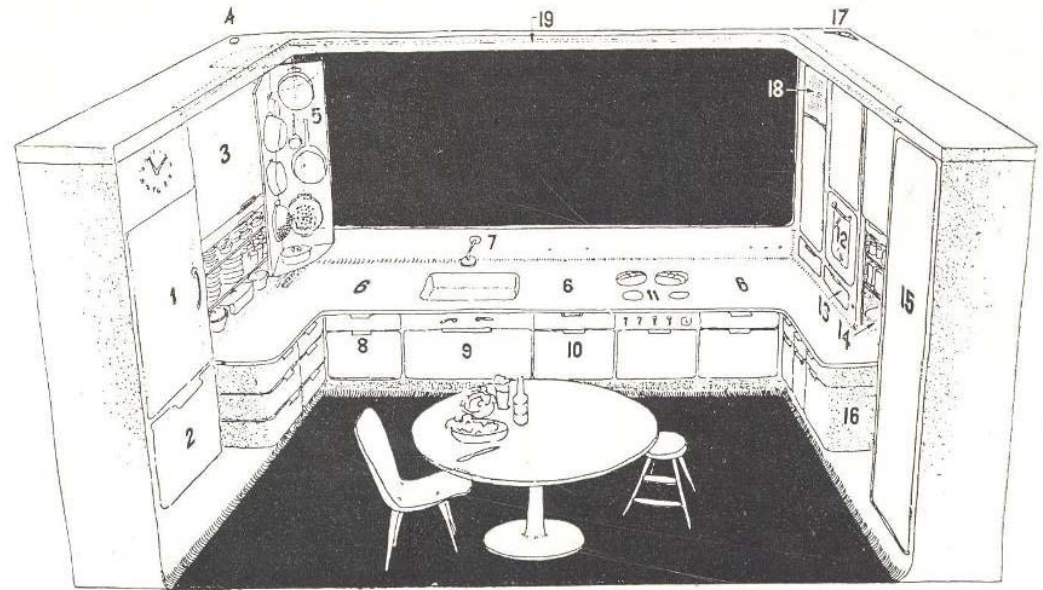

FACTORY - FABRICATED KITCHEN.
 Architect: William Wilson Wurster, San Francisco. 1 shallow refrigerator; 2 deep bottle drawer; 3 vertically sliding doors; 4 plumbing vent; 5 pot and pan storage (swings out for easy reach and uses otherwise inaccessible corner); 6 work table—heat resisting, resilient, cut resistant; 7 non-splash

faucet, controls at front of sink; 8 storage; 9 dish washer and dryer, drawer mounted; 10 garbage drawer connected to disposal unit; 11 pressure cookers; 12 high oven; 13 condiment drawers; 14 toaster, griddle, coffee pot, mixer, etc.; 15 brooms; 16 drawers; 17 heat vent; 18 fan; 19 tube lighting (plus centre lighting).

COMBINED KITCHEN AND BATHROOM UNIT designed as mechanical hub of the house. Extremely compact, measuring about 14 ft. x 5 ft. Architects: Ralph Rapson and David Runnells, Detroit.

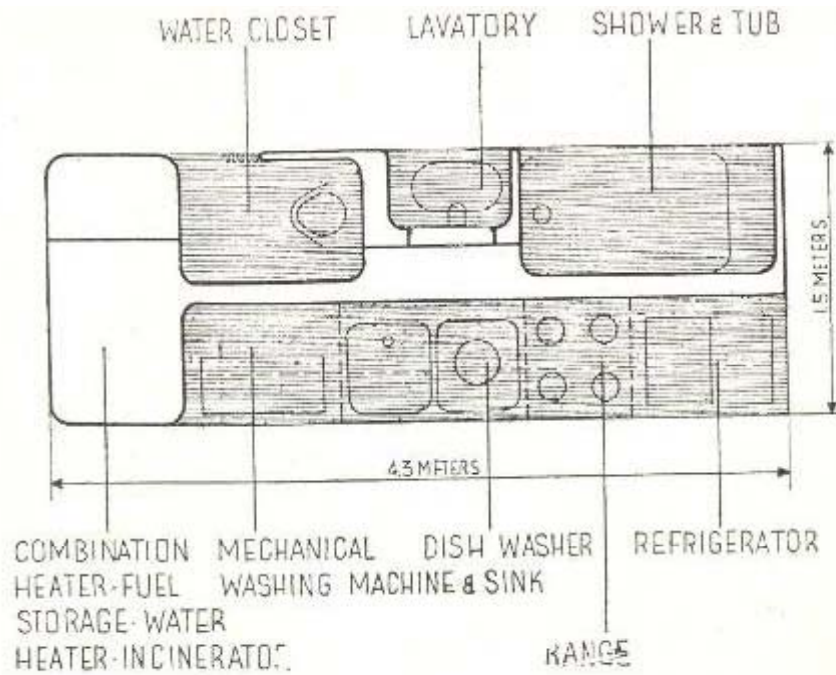

PLAN

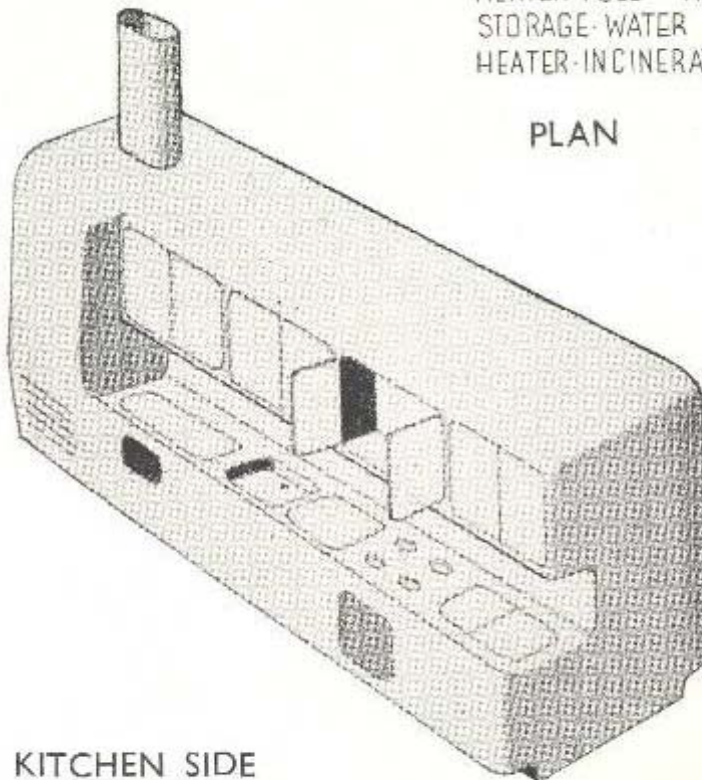

KITCHEN SIDE

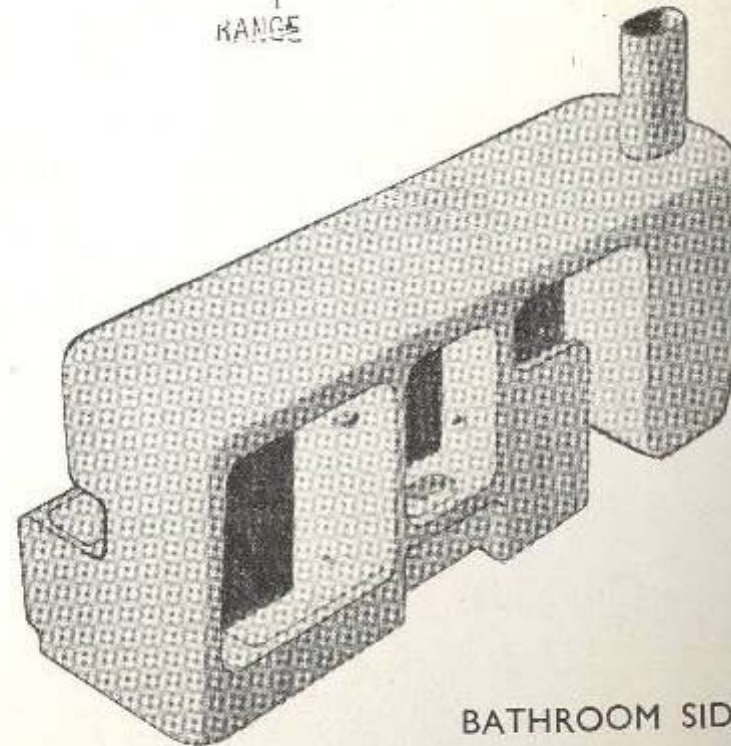

BATHROOM SIDE

Halo, halo, ovdje Radio Zagreb - glas [Božene Begović](#), [15. svibnja 1926.](#), početak emitiranja radio programa u Hrvatskoj



American family watching TV, 1958



[15. svibnja 1956.](#), na 30. obljetnicu emitiranja programa Radija Zagreb u Tomislavovom domu na [Sljemenu](#) proradio je prvi televizijski odašiljač u tadašnjoj [Jugoslaviji](#), ali i u ovom dijelu [Europe](#).

Izravnim prijenosom svečanog otvorenja [Zagrebačkog velesajma](#) na južnoj obali [Save 7. rujna 1956.](#) počelo je emitiranje Televizije Zagreb

Hariri & Hariri : *The Digital House, Project*, 1998



POJAČANA OPSKRBA ENERGIJOM, VISOKOM TEHNOLOGIJOM , OPREMOM (grijanje, vodovod,elek.)

POVEĆANA MOBILNOST (automobil! pojava garaže)

MASOVNA KULTURA I POTROŠAČKO DRUŠTVO (velika količina raznovrsnih proizvoda u kući)

VIŠE SLOBODNOG VREMENA - TV ekrana u kući (radio, hi-fi, kompjutor)

POLOŽAJ ŽENE U KUĆI (masovni odlazak na tržište rada, nestanak posluge iz kuće)

SANITARNO HIGIJENSKA REVOLUCIJA (wc, kupaonice)

PREHRAMBENA REVOLUCIJA (visokotehnologizirana kuhinja)

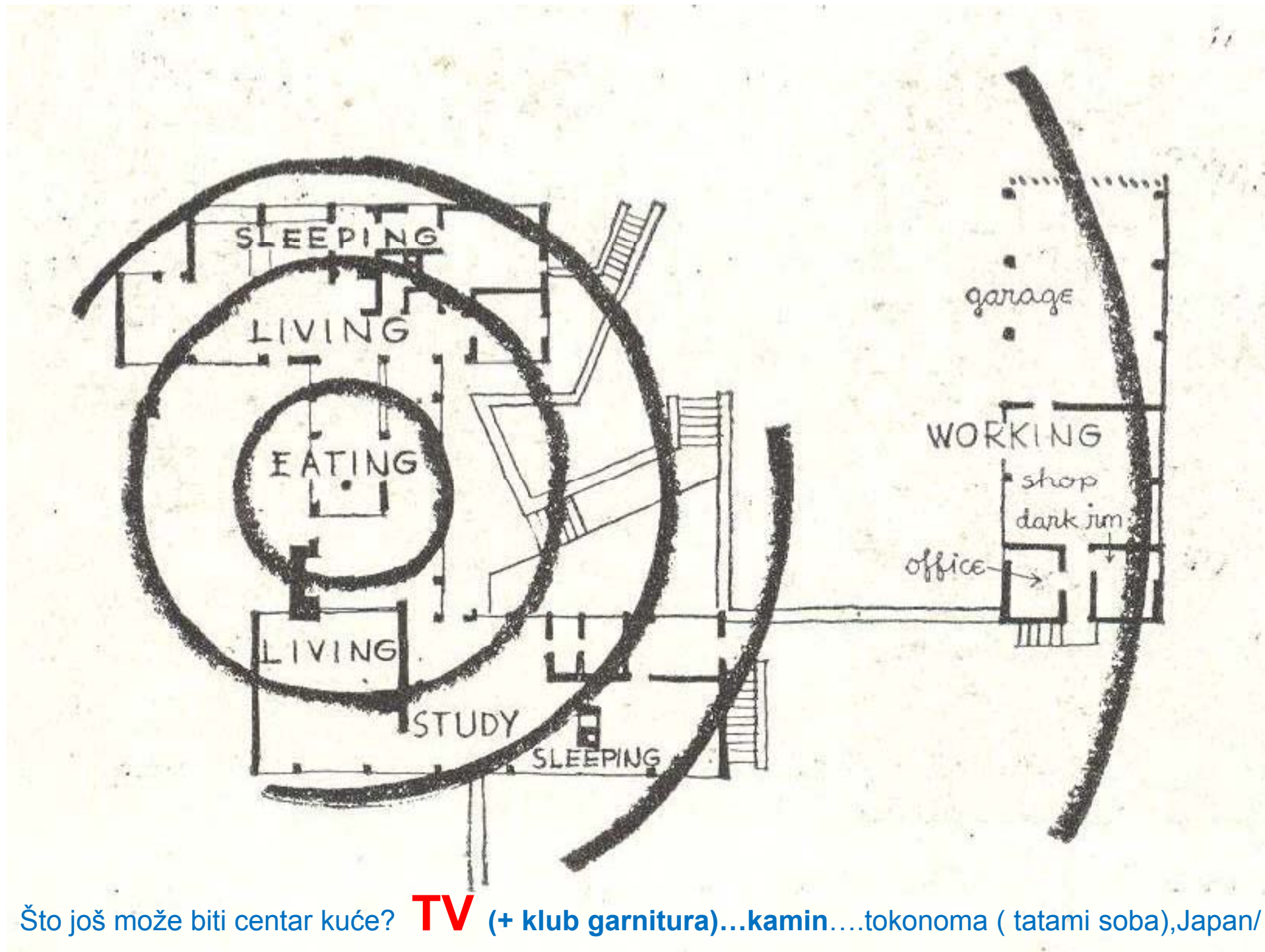

Što još može biti centar kuće? **TV** (+ klub garnitura)...kamin....tokonoma (tatami soba), Japan/

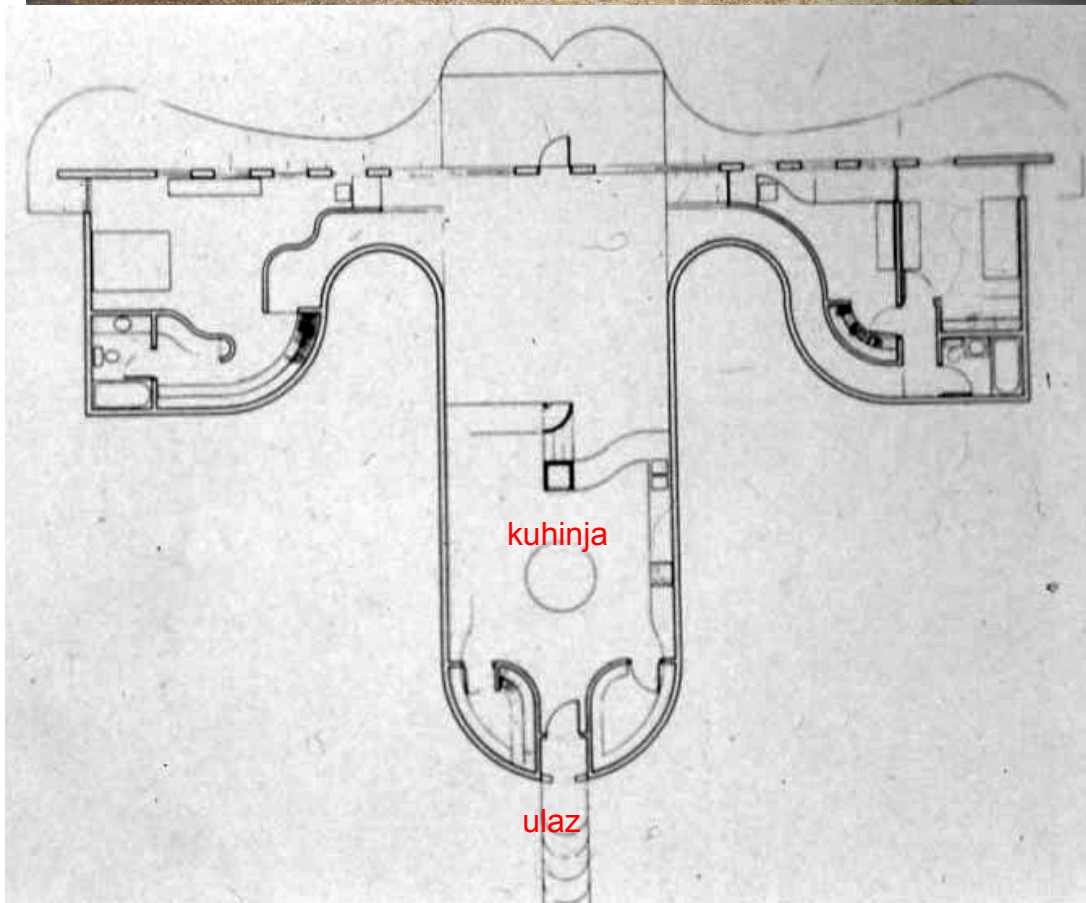
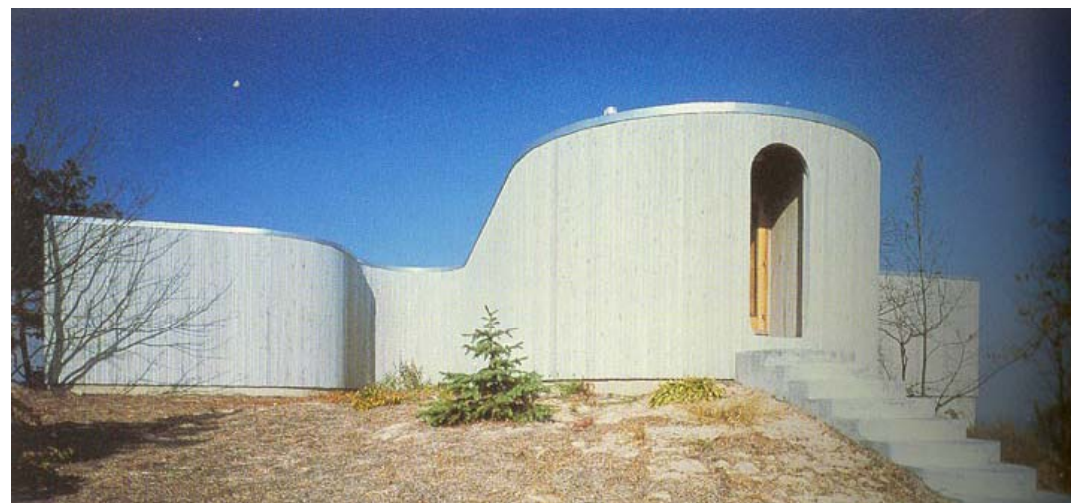

Primjer neobičnog (lošeg?) ulaza u kuću kroz prostor kuhanje-blagovanje

Stanly Tigerman: Daisy House, 1977.

drugi primjer diskutabilnog ulaza u kuću pokraj kuhinje:

ULAZ bez vjetro(termo)brana
Ulazni prostor
bez garderobnog ormara
bez ormara za cipele,
(bez sanitarnog čvora u blizini)

ulaz
(-10/+30)

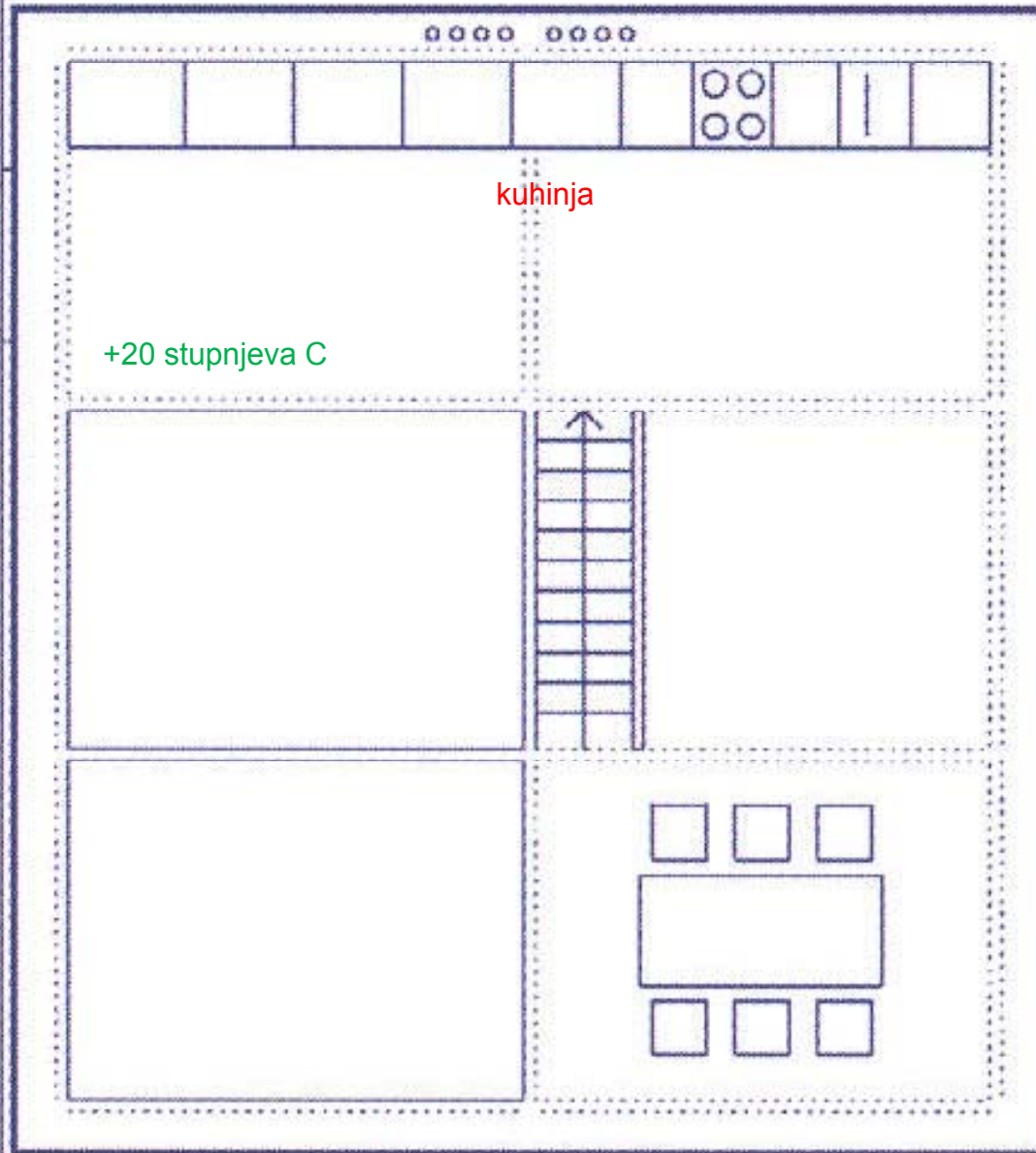

Werner Sobek: R128, Stuttgart



nema slika
nema zavjesa

(?TV)

Fumihiko Maki: Vlastita kuća, Japan, 1990te.



Vrlo je važno u postupku projektiranja obiteljske kuće - definirati odnos KH-BL-DB !

KH + BL + DB

KH BL + DB

KH + BL DB

KH BL DB

Klub garnitura za 12 osoba!

TV?



LeCorbusier

LeCorbusier



Andy Warhol: Mao

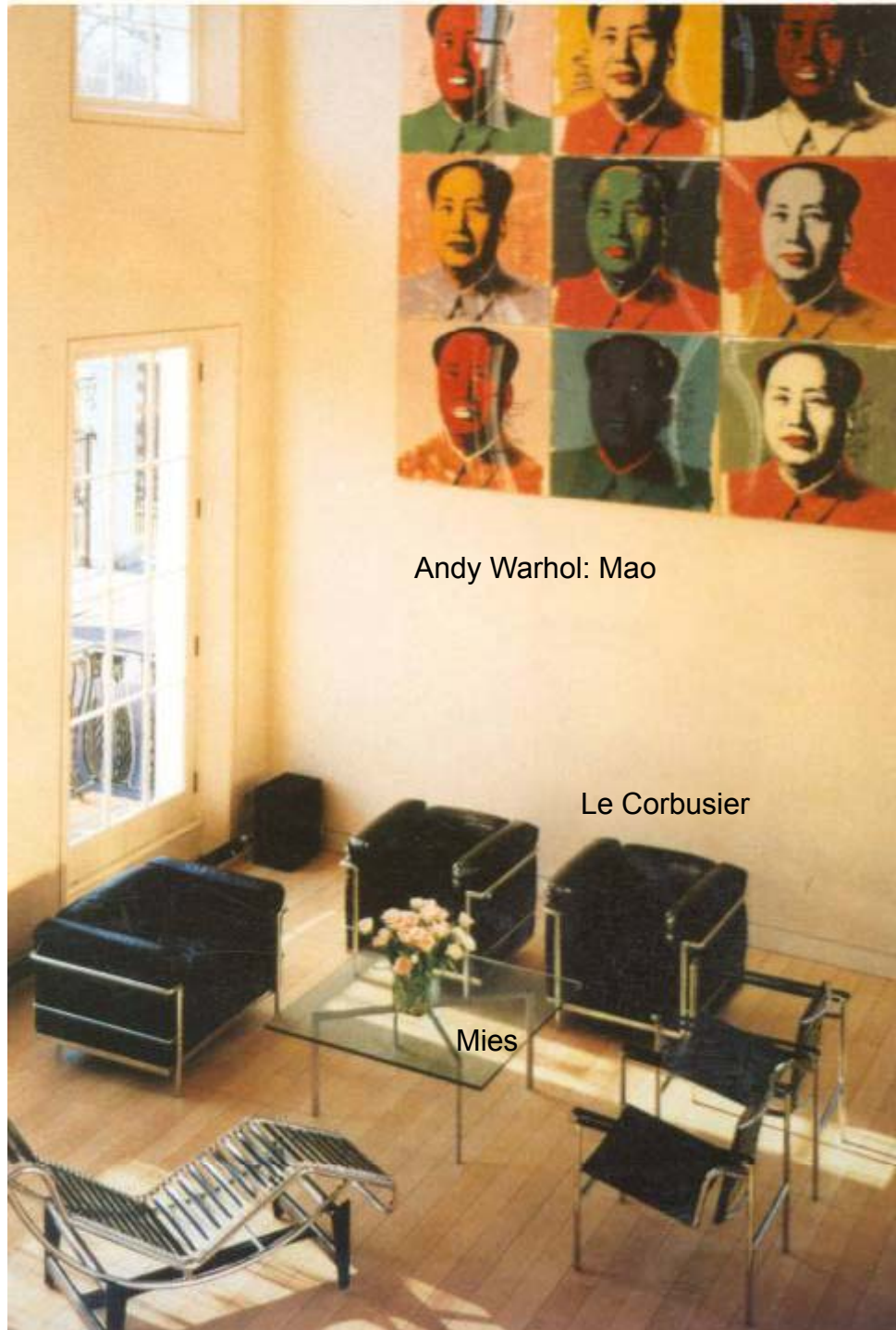

Le Corbusier

Mies

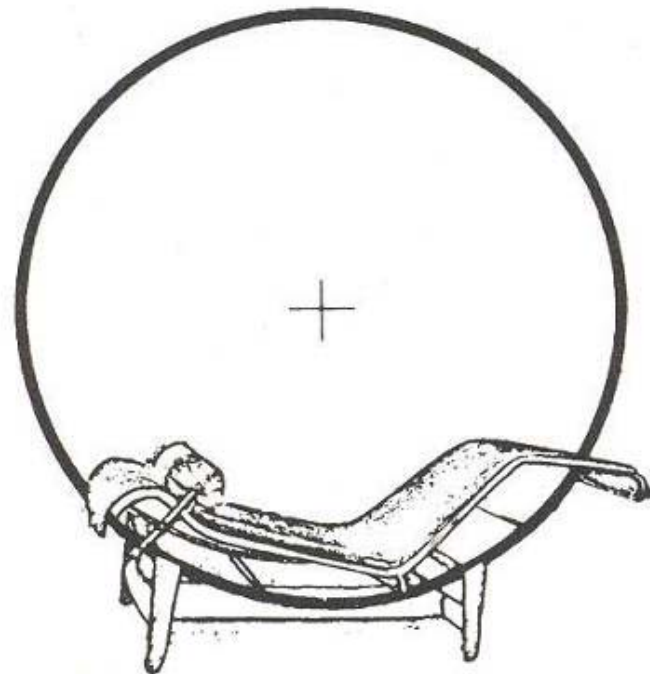

Richard Rogers: Own home, London



Chaise Longue "Basculant" 1928.



Koja je točno namjena u korištenju ove ležaljke?
Kratki odmor, drijemanje ? čitanje knjige, časopisa, novina? gledanje televizije?
Nema rukonaslona! Koliko se dugo može koristiti? 15', pola sata , sat ili duže?

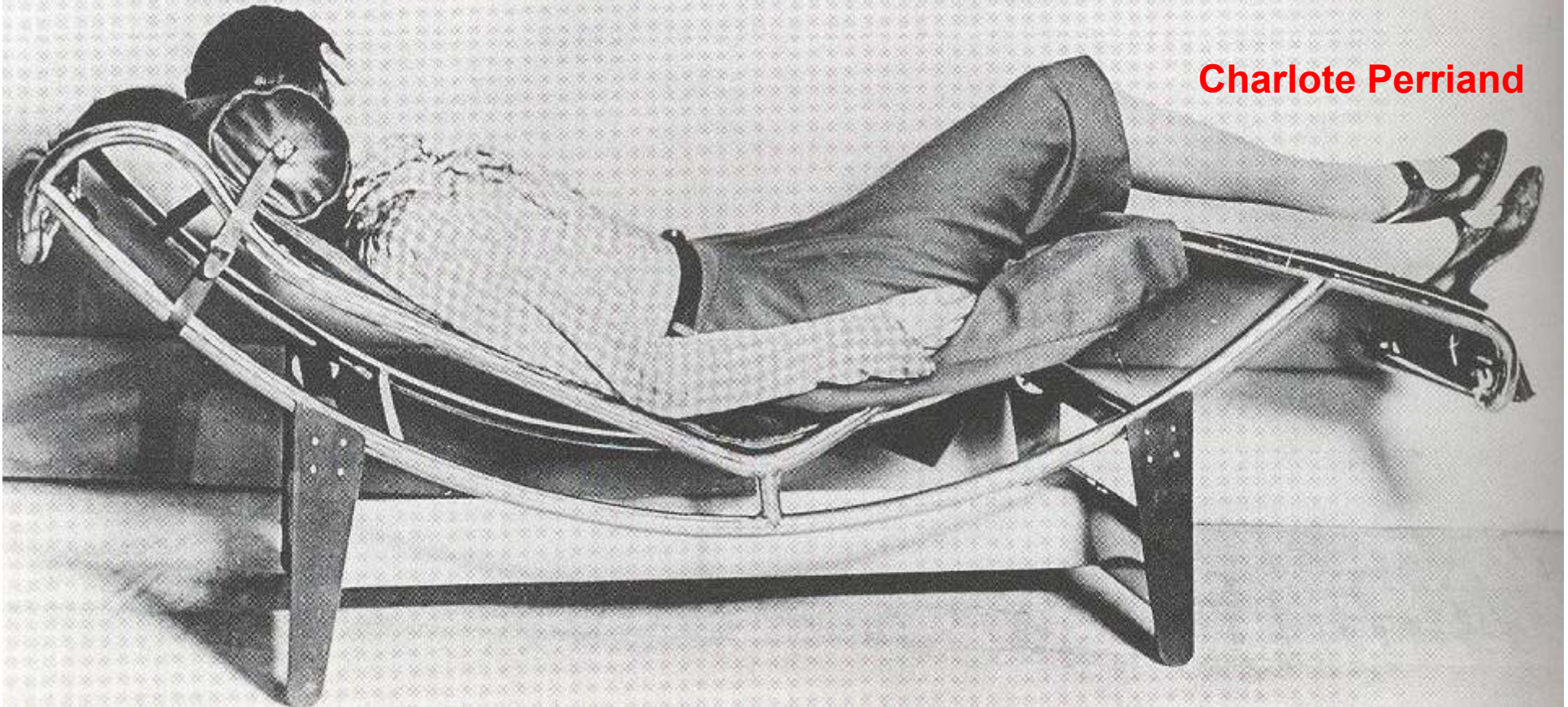

Charlotte Perriand

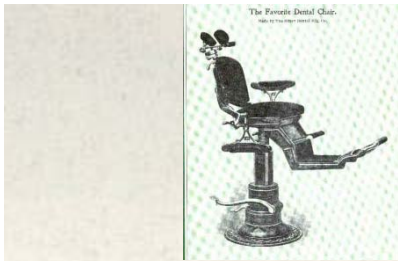

“reference”?



LC4, 1965 (1928), Le Corbusier.*

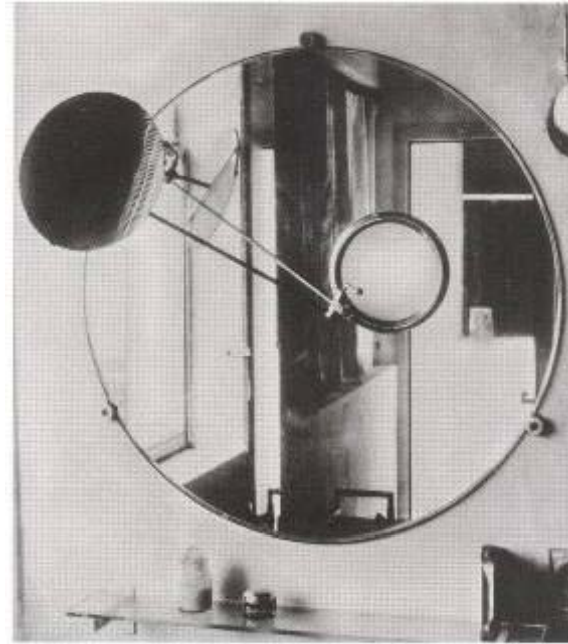

Eileen Gray



Mies Van Der Rohe, "Barcelona" 1929.



G.T. Rietveld, Armchair "Red/Blue", 1918.



Marcel Breuer, "Wassily", 1925/26



var Aalto, "Armchair" 1930/33.



455-458
Charles Eames



Eames "Bigger" Lounge

We'll...Vitra's second Eames release this year. They have worked with the Eames Office to update the chair and make a larger version for taller people. I thought they might just scale up the chair all over to keep the proportion the same, but it looks like they increased the depth of the seat and backrests are taller. People are taller now than in the 1950's and as a former sales person, there were many times a person would sit in that chair and not quite fit.

Charles Eames, Lounge chair, 1956.



Paul Rudolph tubular chrome and acrylic rolling armchair

| | | |
|-----|-------------|-----------------|
| Cat | 202.000.000 | (USA) 93.6 M |
| Dog | 171.000.000 | (USA) 77.5 M |



Around 63% of all U.S. households (71.1 million) have pets, and more than half of these households have more than one animal.^[2] The two most popular pets in most Western countries have been cats and dogs. In the United States, a 2007-2008 survey showed that dog-owning households outnumbered those owning cats, but that the total number of pet cats was higher than that of dogs.

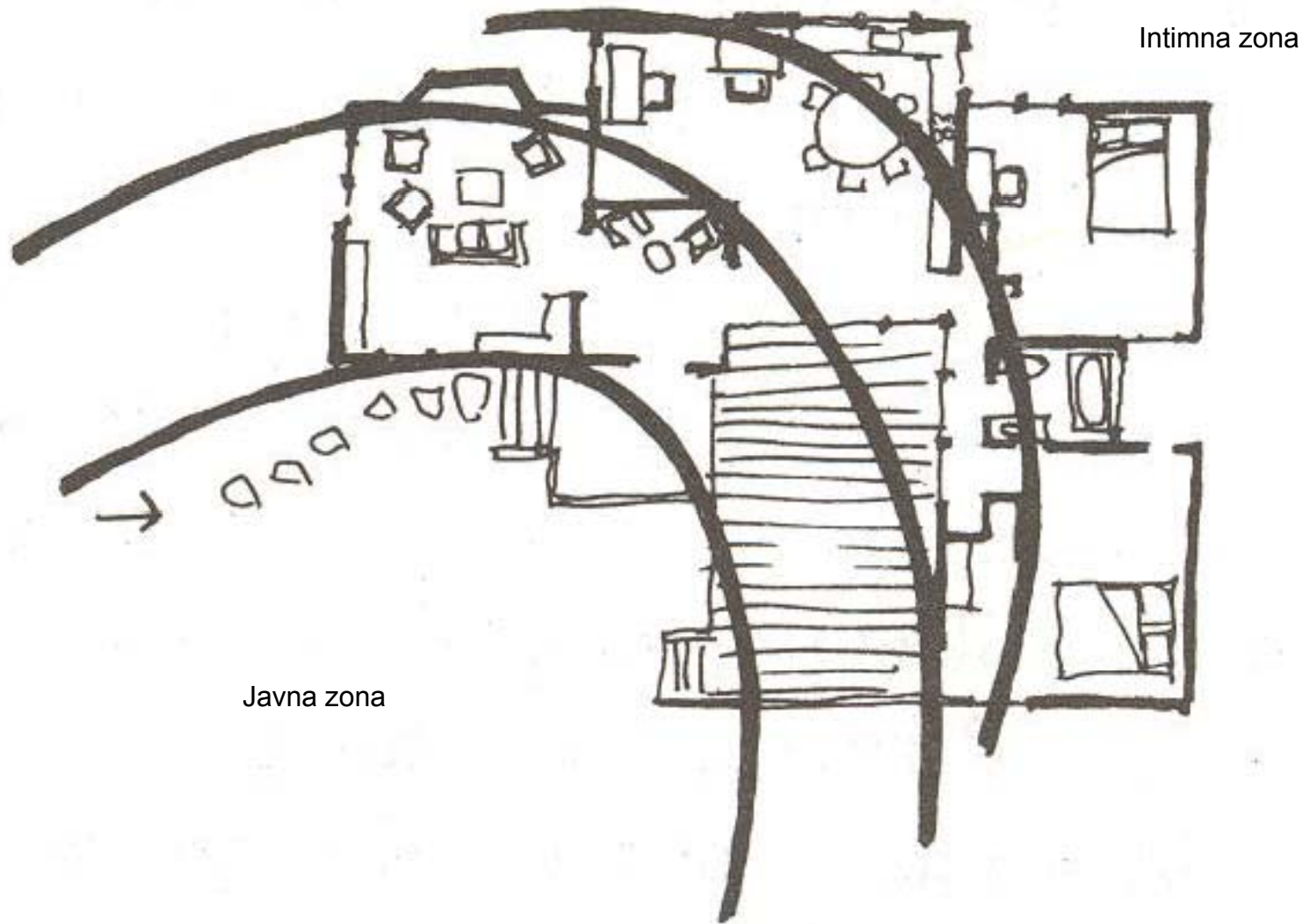

Intimacy gradient in a house.

INTIMNOST KUĆE

- = potreba da članovi imaju svoje osobne prostore (“ego-prostori”)
- = zvučna i vizualna izolacija roditelja i svakog ostalog člana obitelji



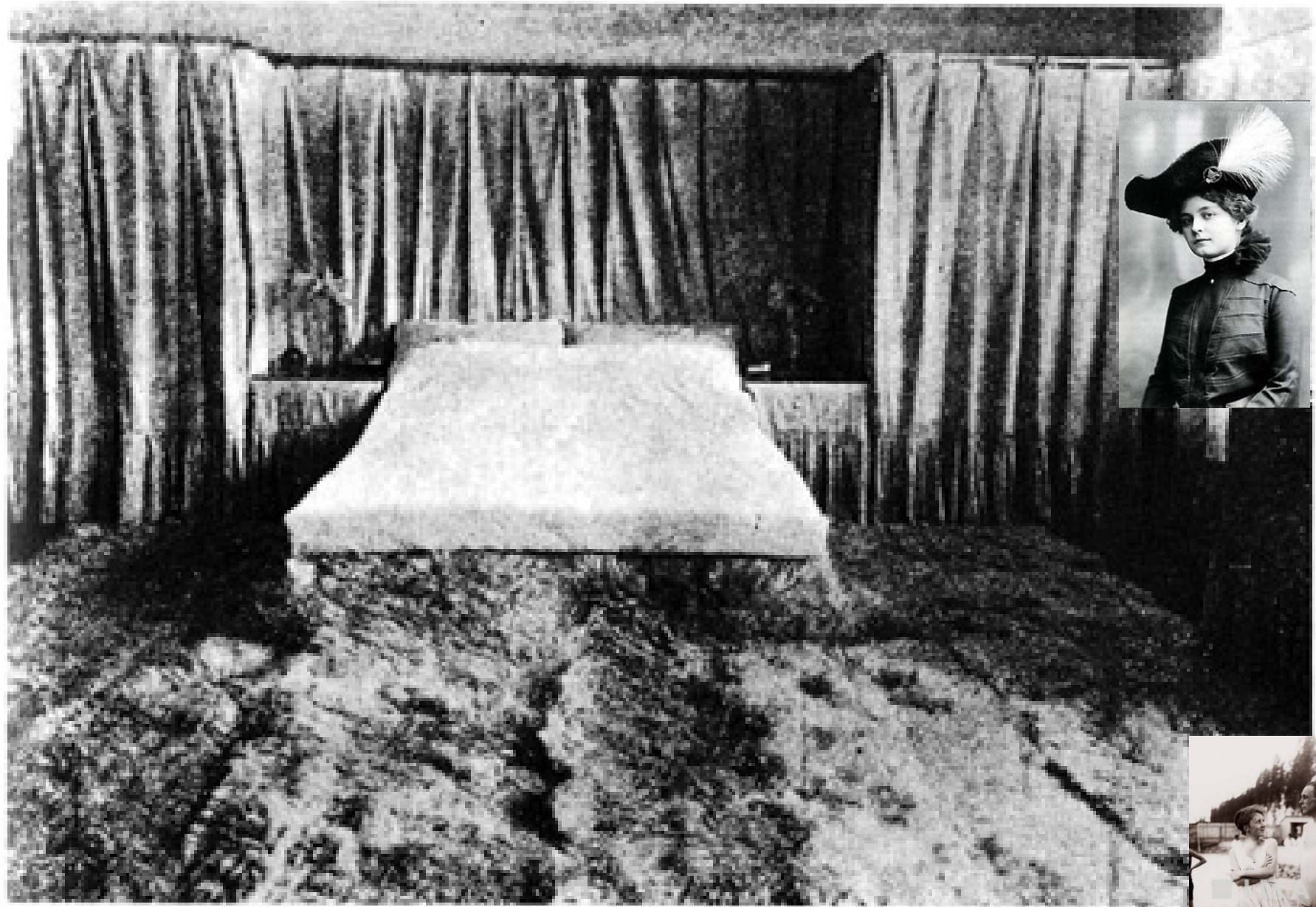

17 LOOS APARTMENT.
Bedroom of Loos's wife, Lina. Photo: 1903.

Lina 1902-1905
Elsie 1919-1926
Claire 1929-1932

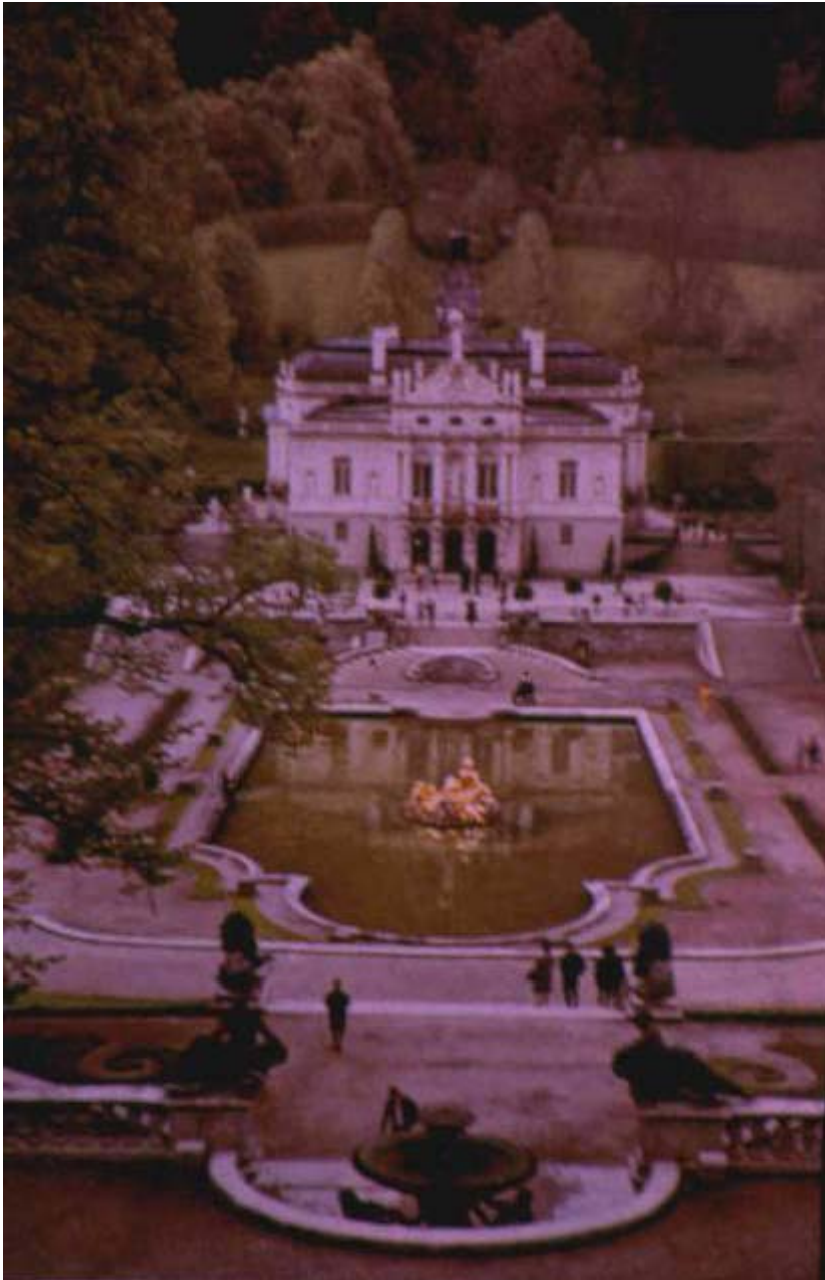

kraljevski raskošna, upitno funkcionalna spavaonica

Dvorac Linderhof (Ludwig II Bavarski), 1870.



Lilly Reich

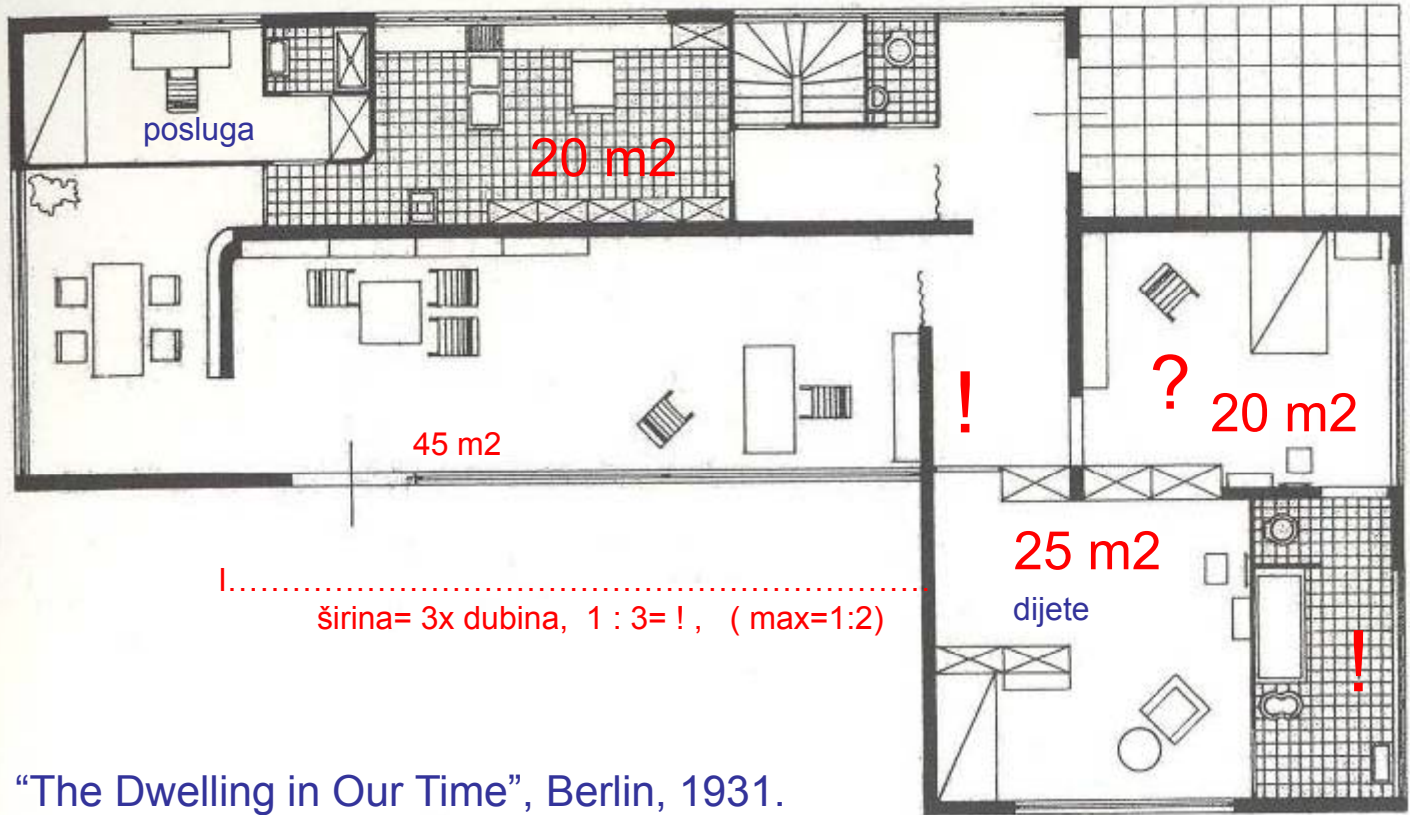

“The Dwelling in Our Time”, Berlin, 1931.



Lilly Reich

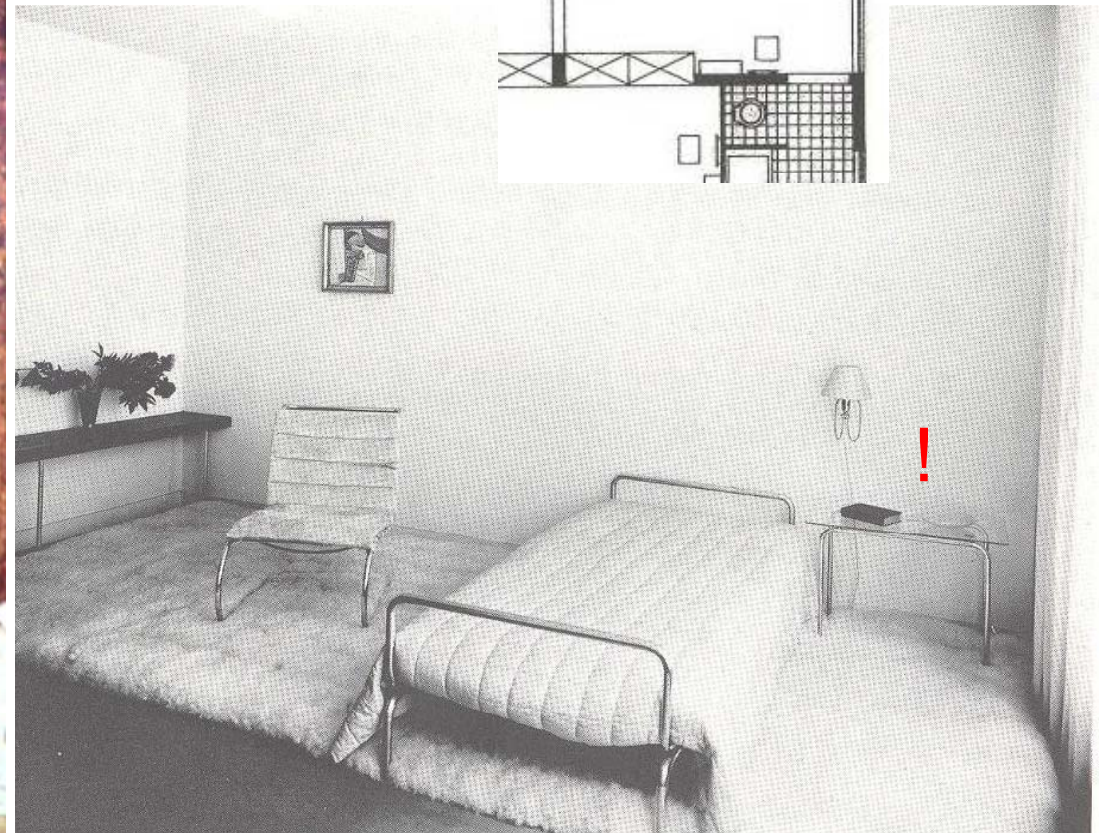
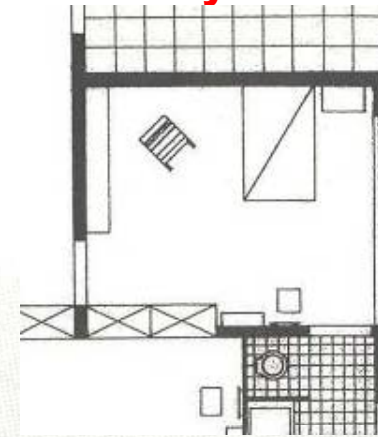

skromna u opremi , više od potrebne kubature zraka,
“funkcionalno “ (moderno) projektirana spavaonica
(iako nije jasno kome je namijenjena – vidi tlocrt-?)

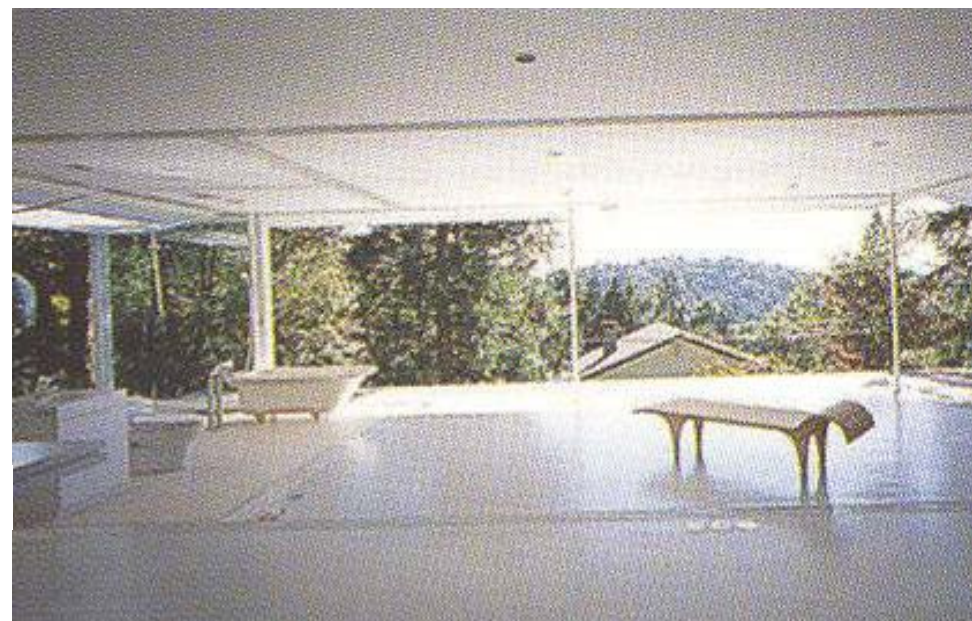
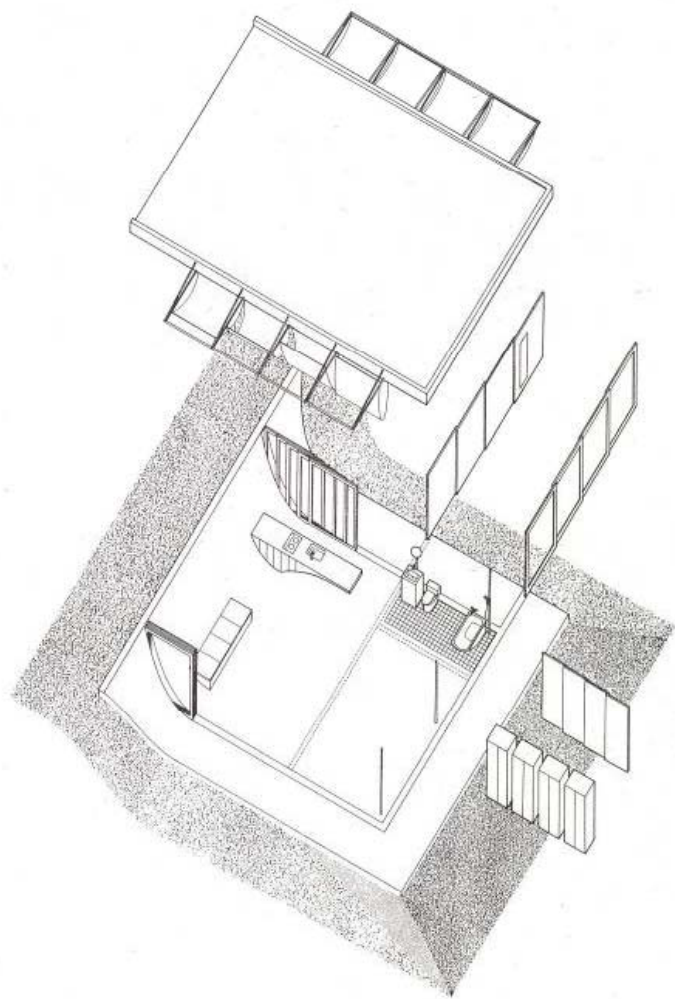

Shigeru Ban: Curtain Wall-less House, Japan, 1997.

GUEST HOUSE potpuno je zatvorena!

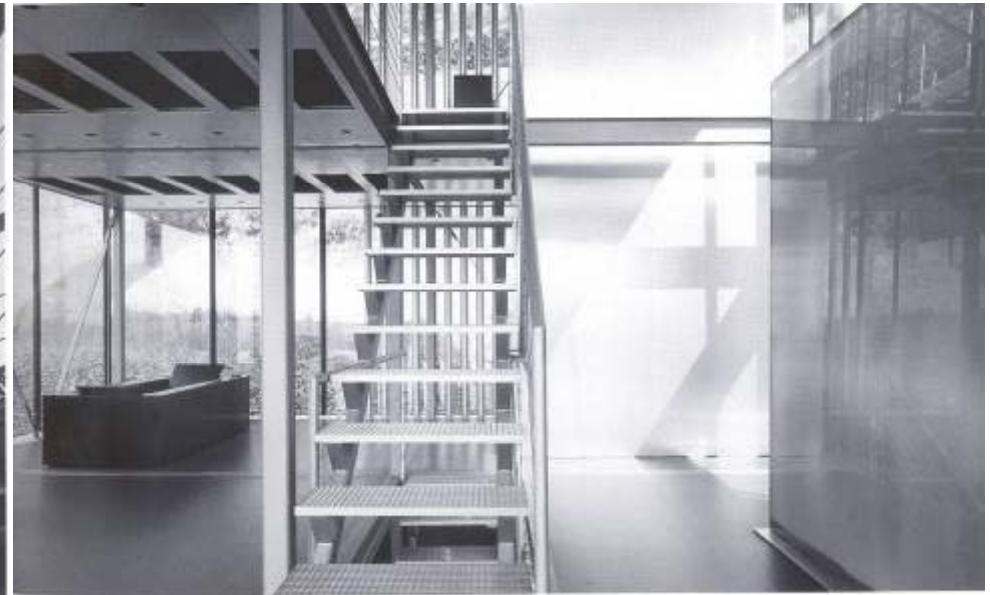

total-raum
prikladan samo za samca ili par (couple)

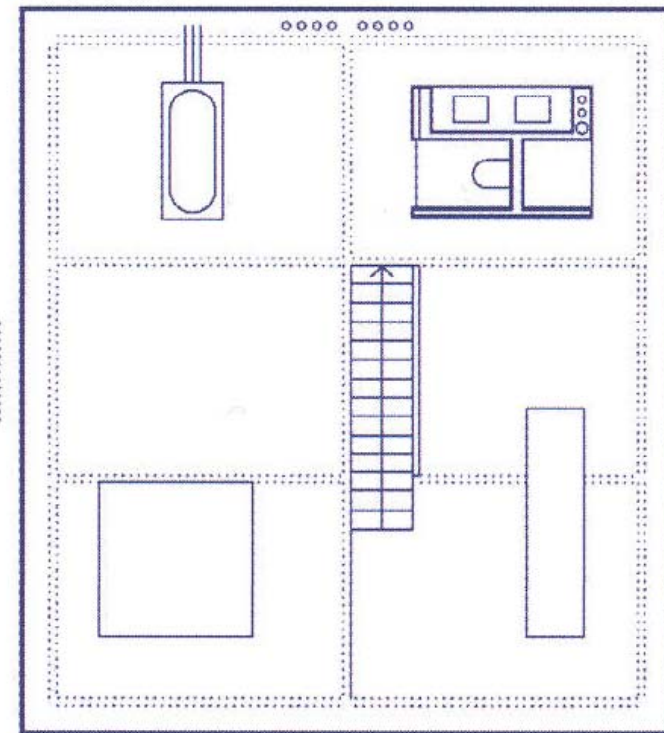

Werner Sobek: R128

PRIVATNOST KUĆE

= odnos prostora kuće i vanjskog okruženja

= stupanj zaštite i psihofizičke sigurnosti obitelji obzirom na izvanjske okolnosti

STAKLENKA -GLASS HOUSE



Sobek: R128, 2002.

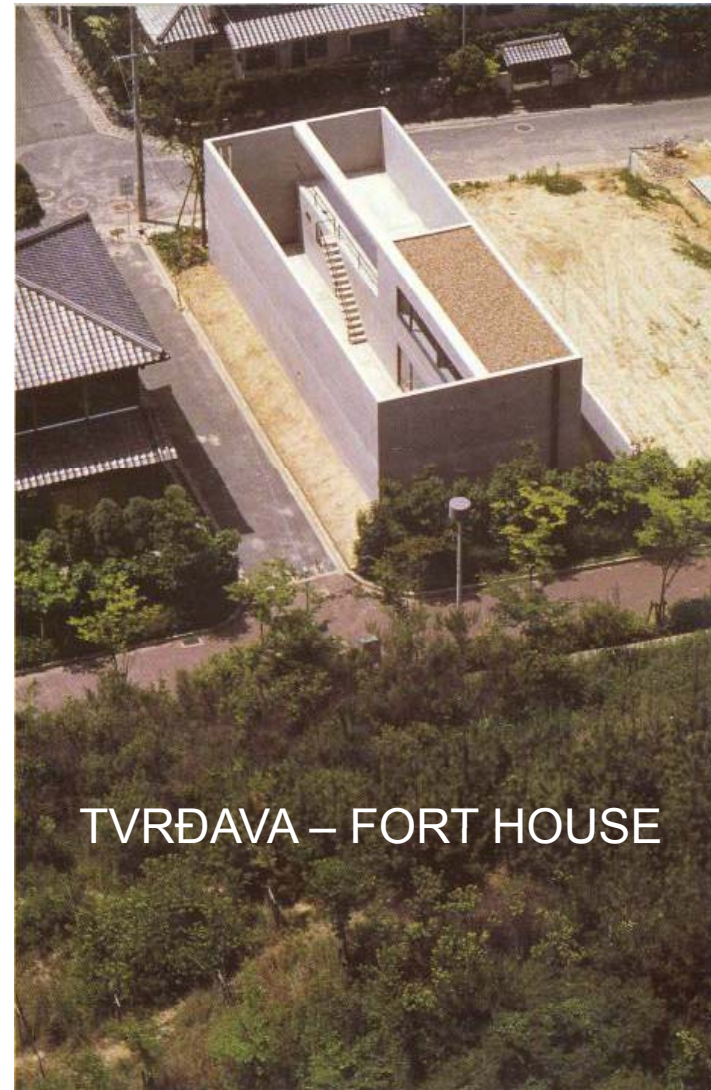

TVRĐAVA – FORT HOUSE

Ando:Nakayama, 1985.

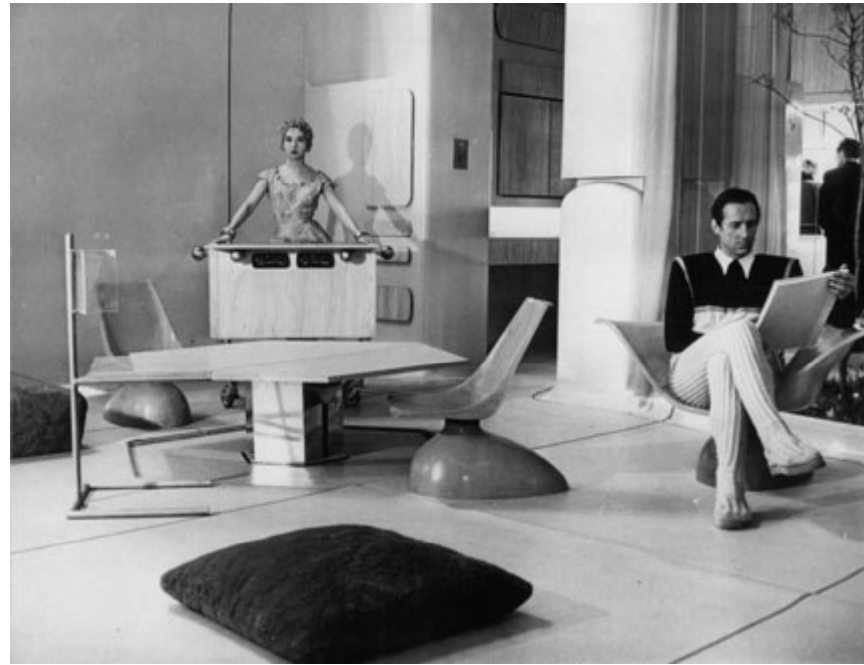

A&P Smithson, **Future House**, 1958.

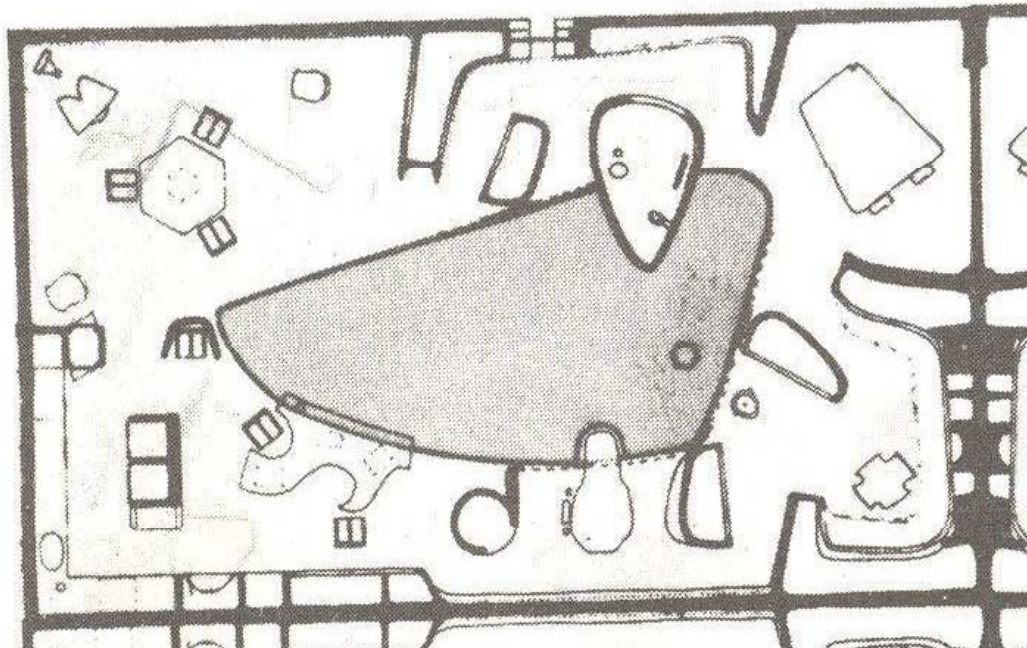

Mario Botta: kuće TVRĐAVE , Ticino, Švicarska



Breganzona, Ticino, (1984-1988)



fortifikacija, utvrda, TVRĐAVA

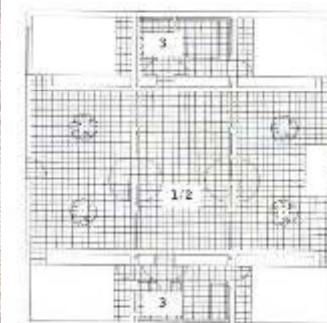

Campo Baeza: Casa Gaspar, Cadiz, Spain, 1990.

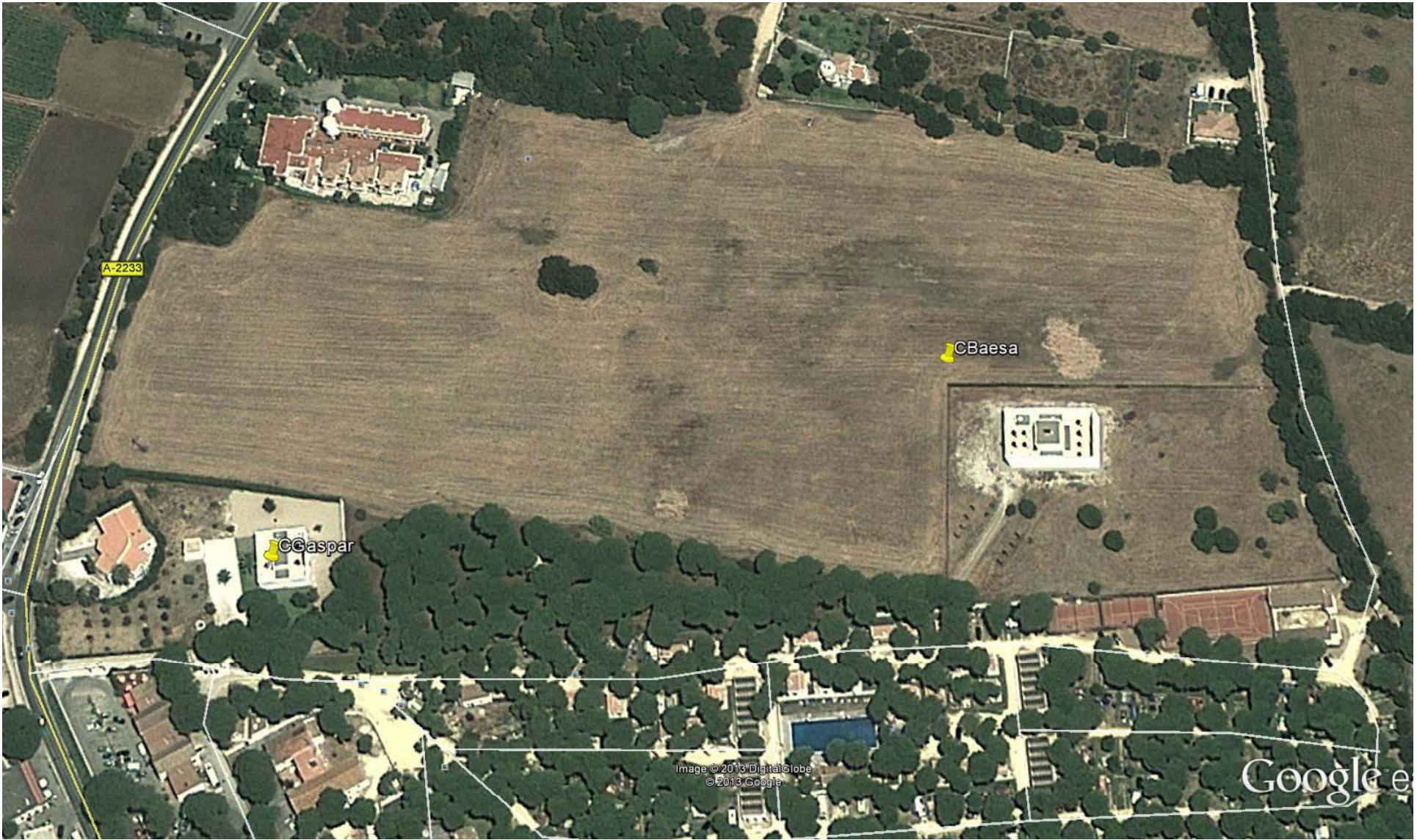

Campo Baeza



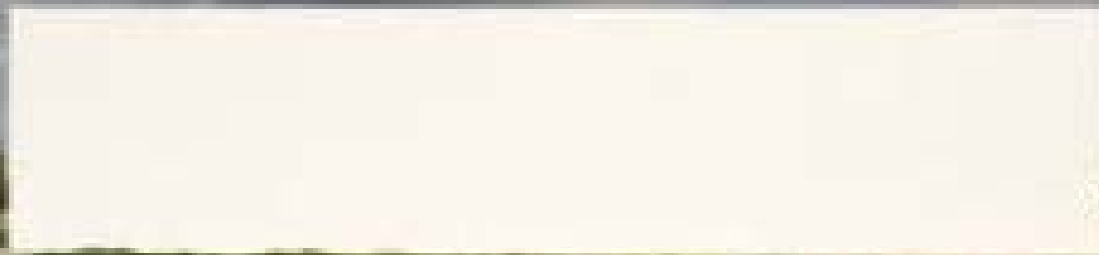
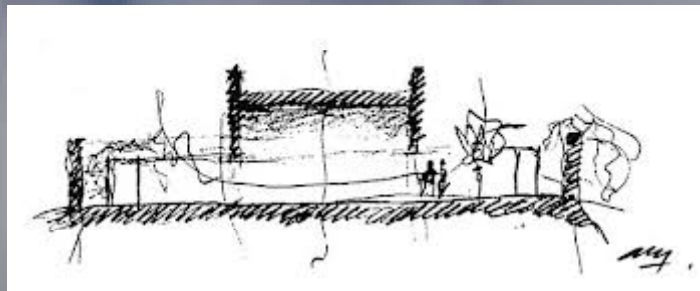

Alberto Campo Baesa : Casa Casa Guerrero, Cadiz , 2005.

Manuel and Francisco Aires Mateus
Casa Alentejano, 2005.



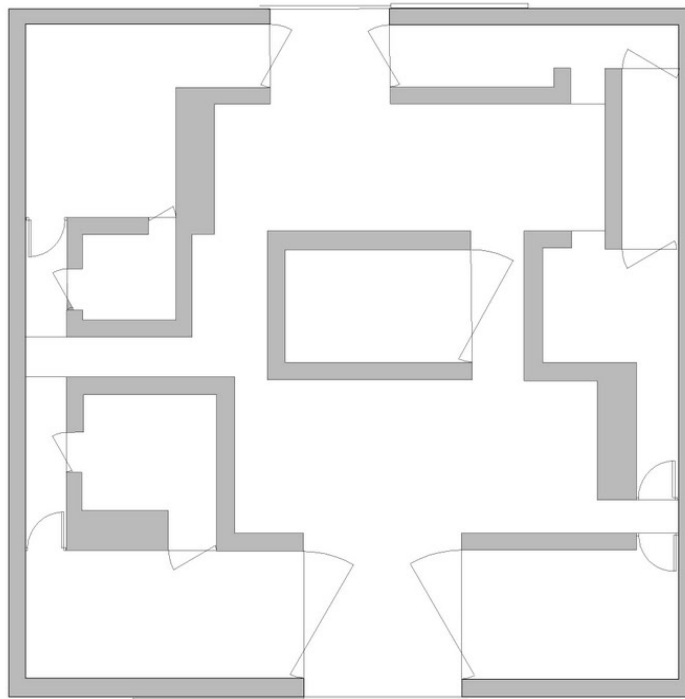

Manuel and Francisco Aires Mateus
Casa Alentejano



Apollo Architects : MUR House, Yokohama Japan, 2011.(Project Area: 80.39 sqm)



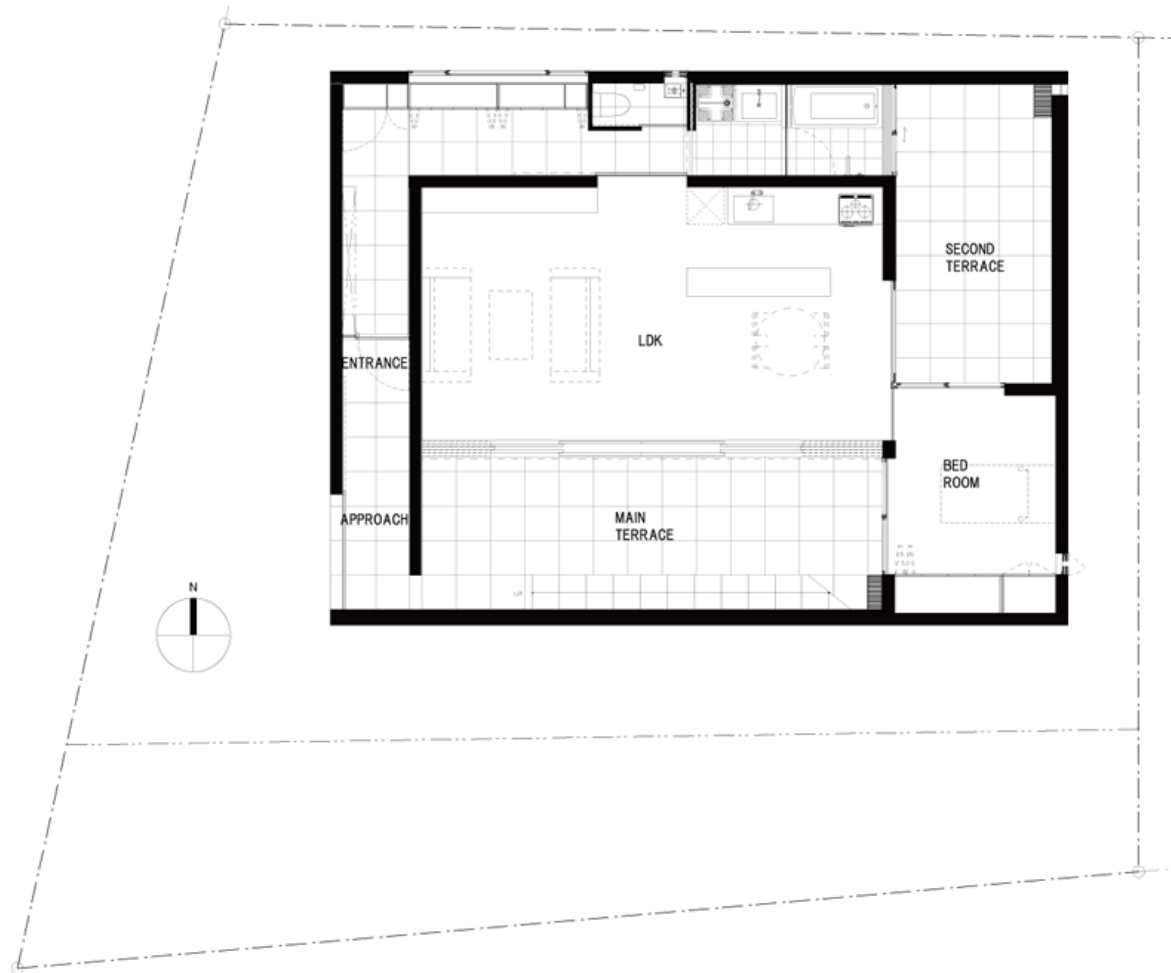

Apollo Architects : MUR House, Yokohama Japan, 2011.(Project Area: 80.39 sqm)

House-T / Tsukano Architect Office

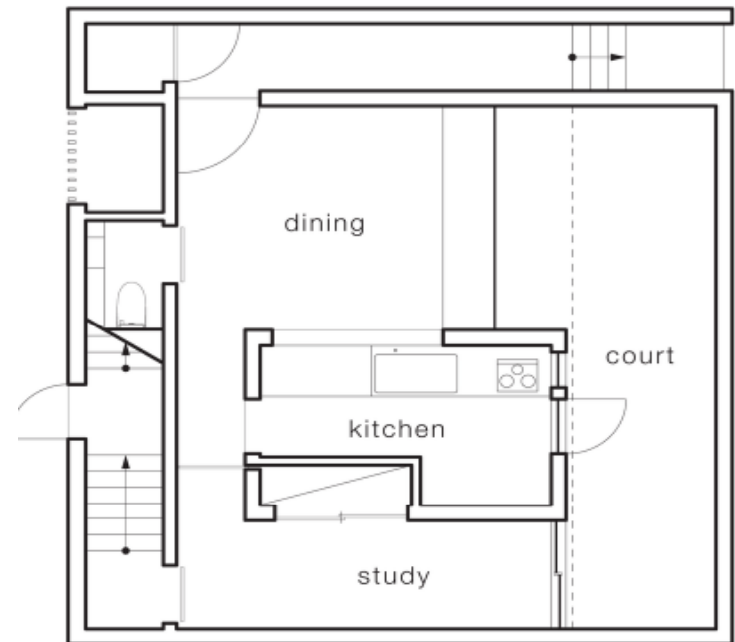
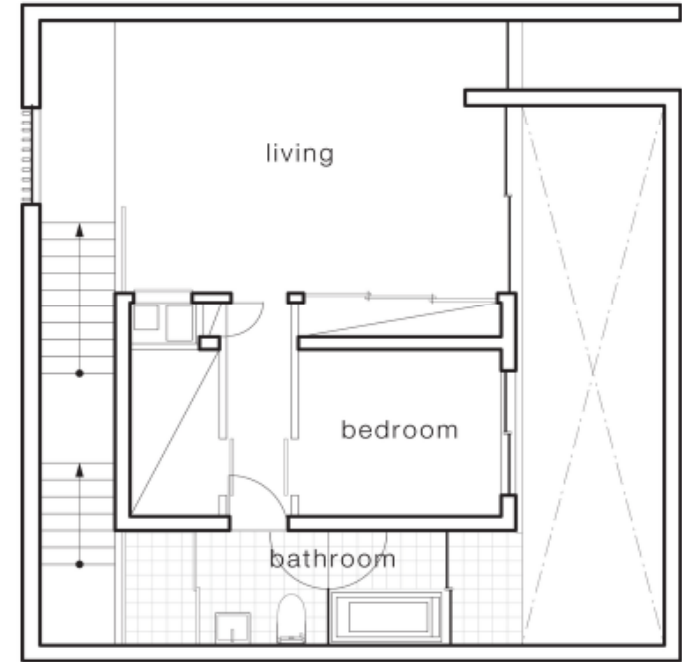

UTVRDA



Tadao Ando, Horiuchi House, 1978.

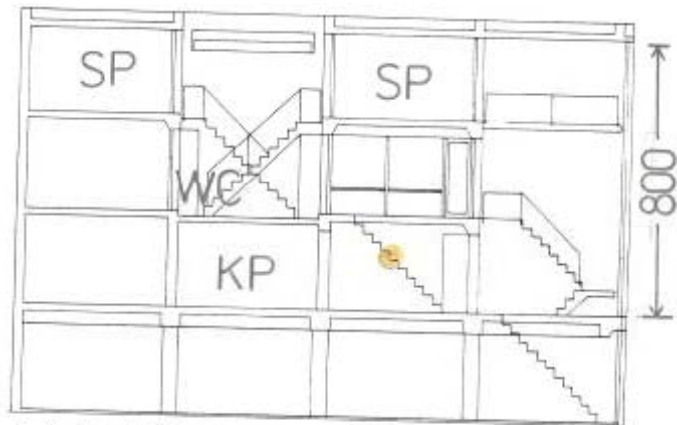

Sezione longitudinale *Longitudinal section*

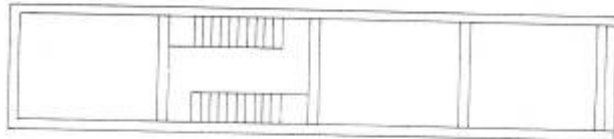

Pianta piano tetto *Roof level plan*

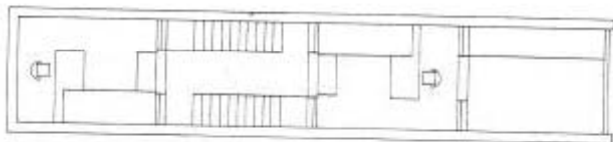

Pianta piano terzo *Third floor plan*

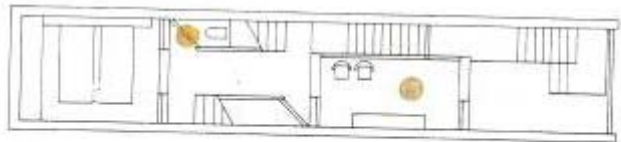

Pianta piano secondo *Second floor plan*

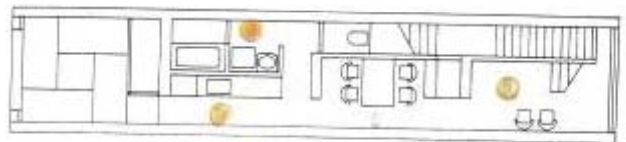

Pianta piano primo *First floor plan*

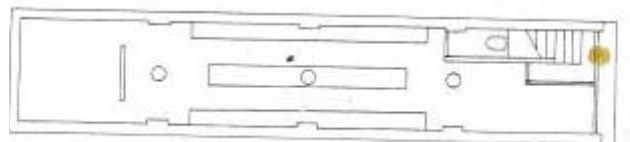

Pianta piano terreno *Ground floor plan*

800
200
290

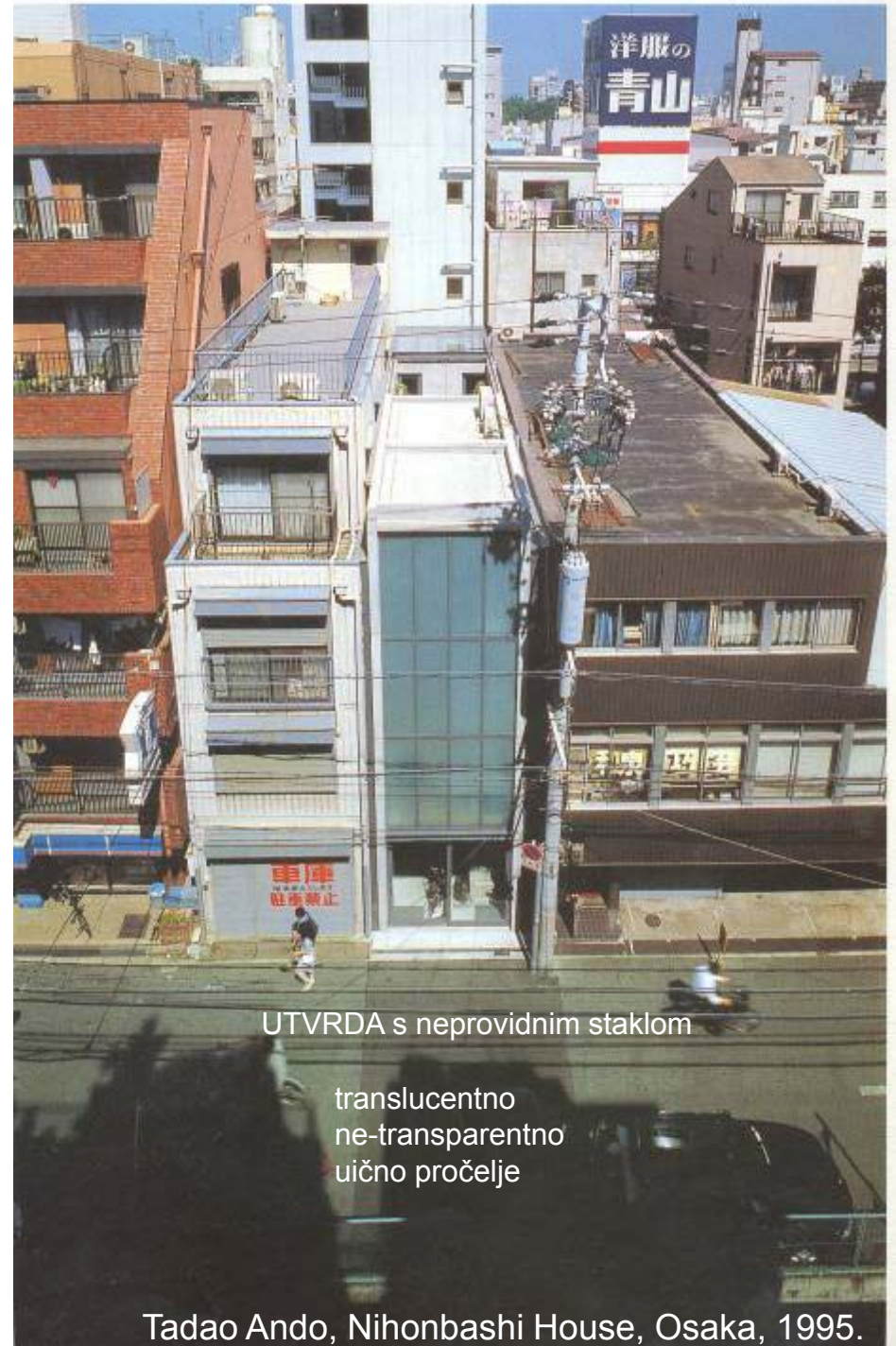

UTVRDA s neprovidnim staklom

translucentno
ne-transparentno
učno pročelje

Tadao Ando, Nihonbashi House, Osaka, 1995.



Tadao Ando, Nihonbashi House, Osaka, 1995.



Shinichi Ogawaa: House in Okinawa, Japan, 2009.

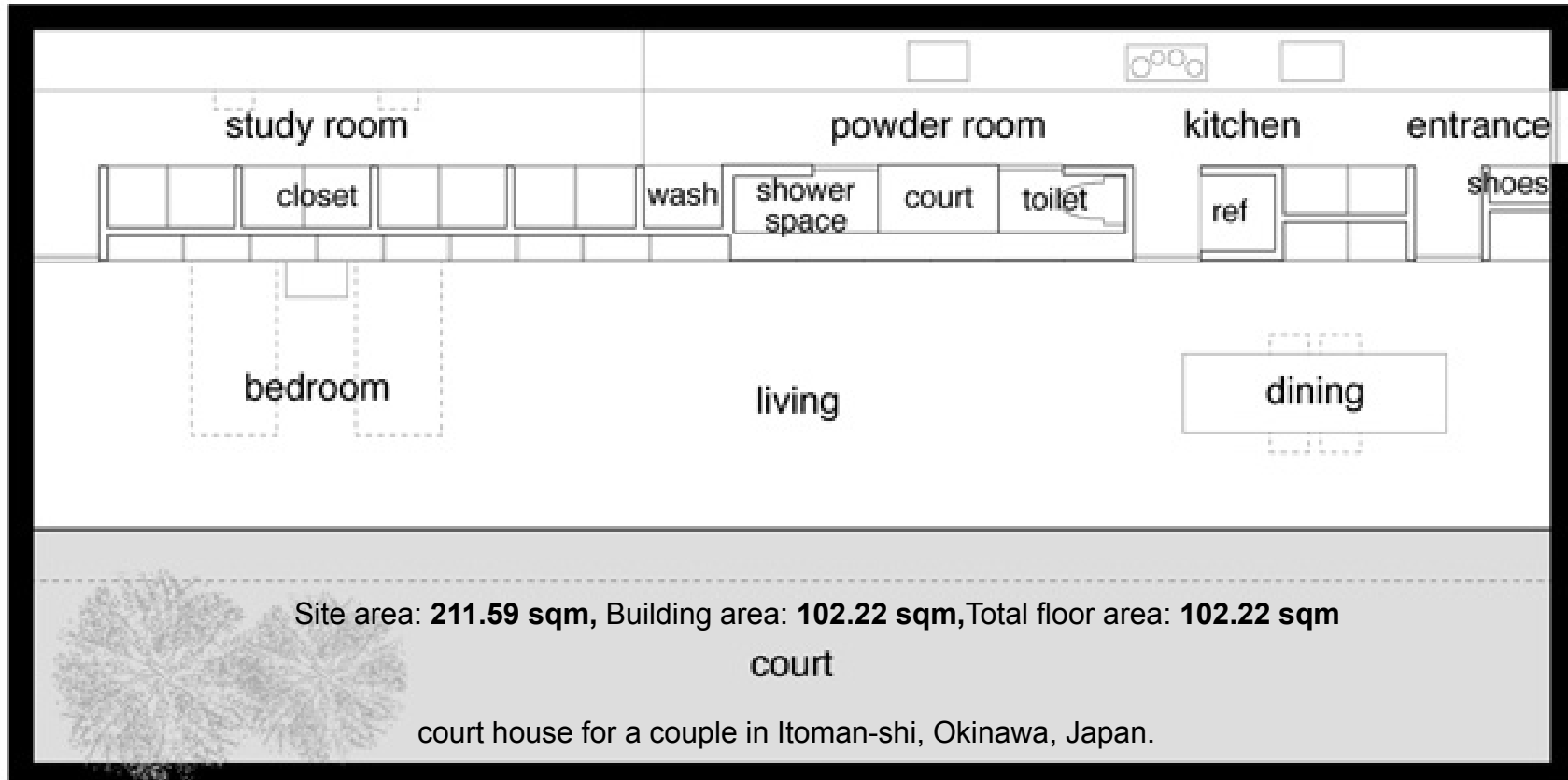

6 x 6 6 m glass cube

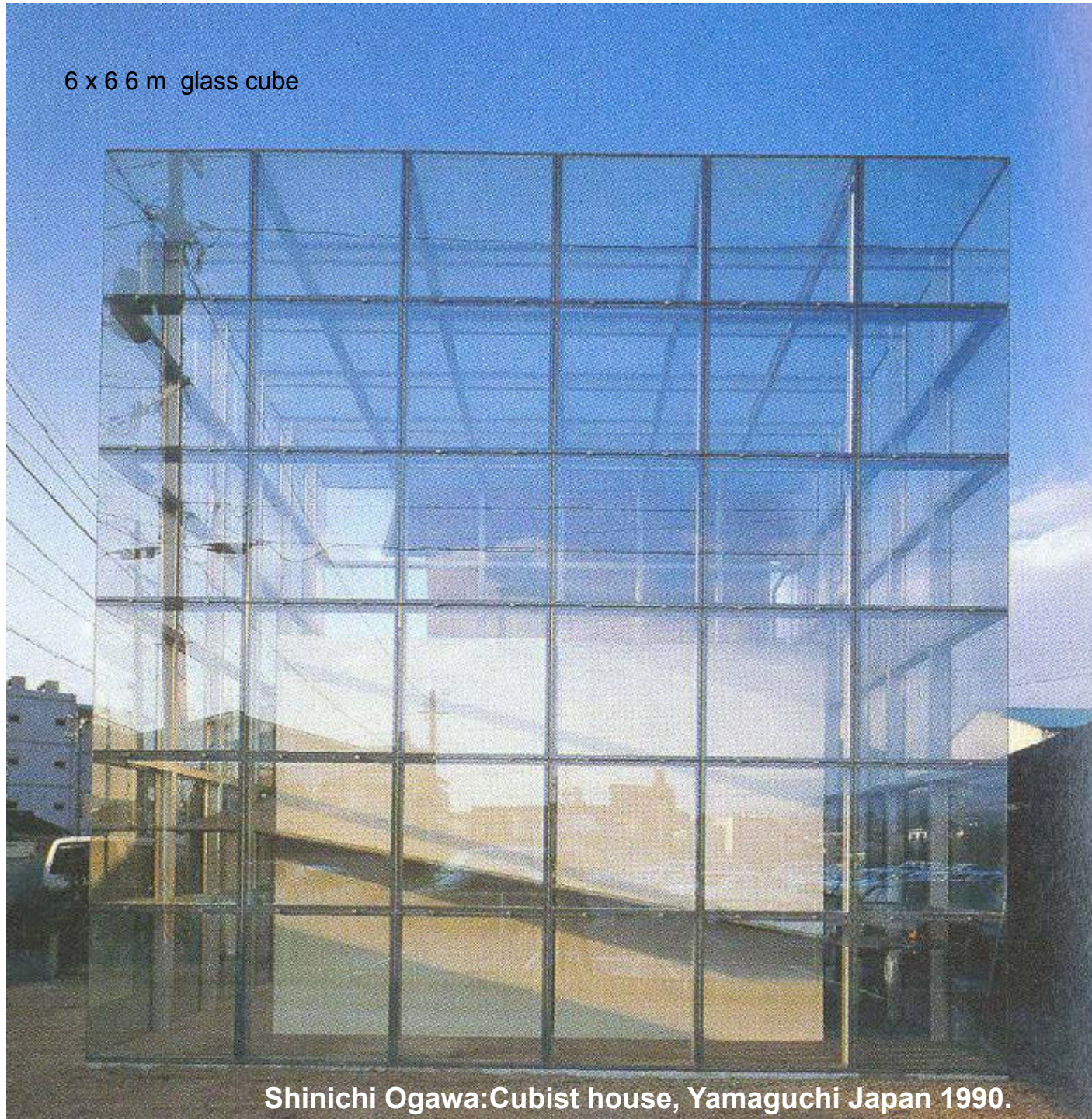

Shinichi Ogawa: Cubist house, Yamaguchi Japan 1990.

- Building area : 35.96 m²
- Total floor area : 71.92 m²



This building consists of a home and two studios for an artist working in three dimensions. The exterior is 6m × 6m × 6m glasscube. Four cubes secure a particular presence as large furniture and function object ; light slits receive light (by day) and emit it(by night) , creating exchanges with the natural environment .The slope is transparent, and the floor enclosing the four cubes turns as it moves to the upper levels.The Cubist House is experiment in designning space that supports creation in that domain intermediate to architecture and housing, furniture and industrial design.

Site area : 102.07 m²,Building area : 35.96 m²,Total floor area : 71.92 m²
completion date : 2008.04

Shinichi Ogawa:Cubist house, Yamaguchi Japan 1990.



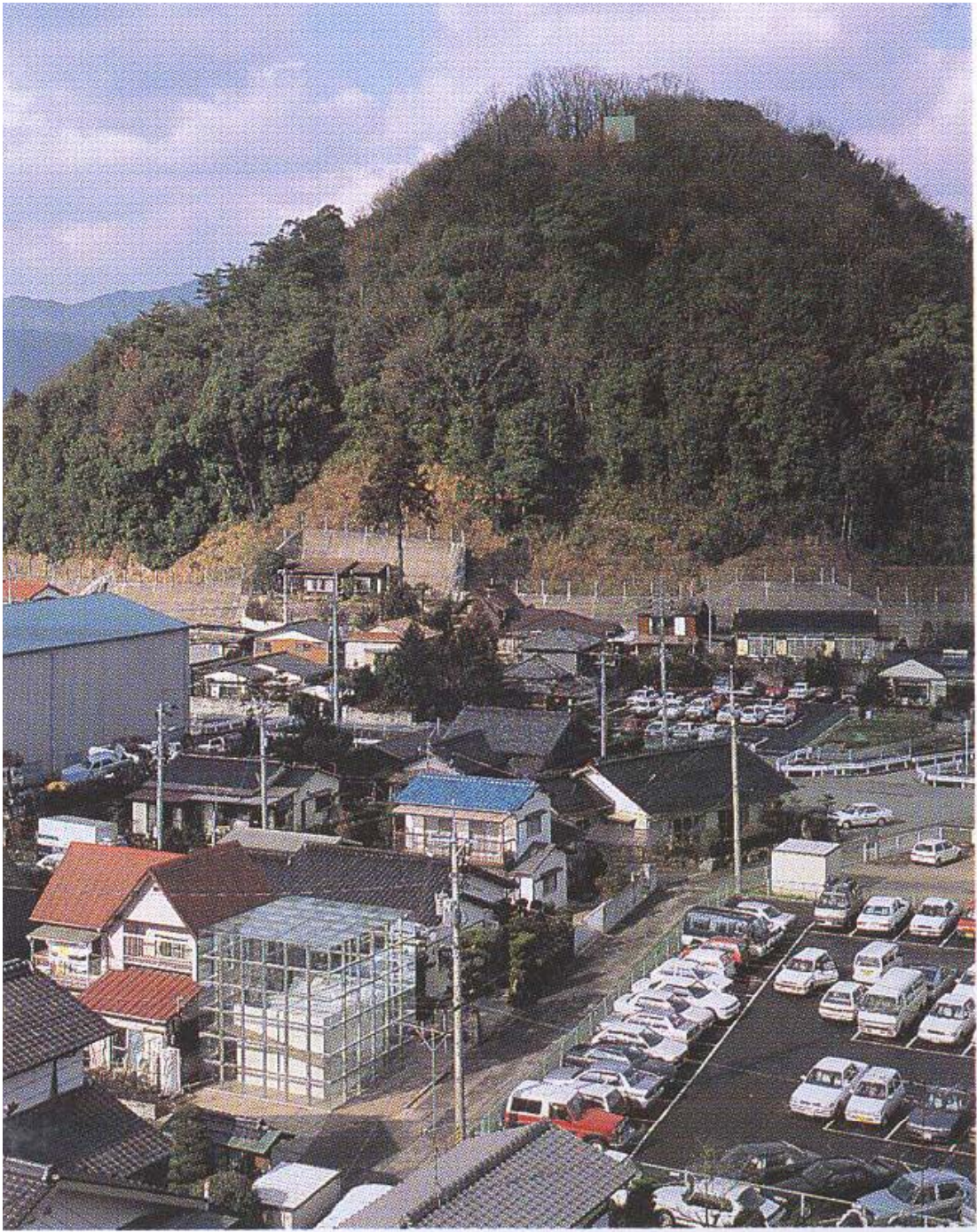

Shinichi Ogawa: Cubist house, Yamaguchi Japan 1990.

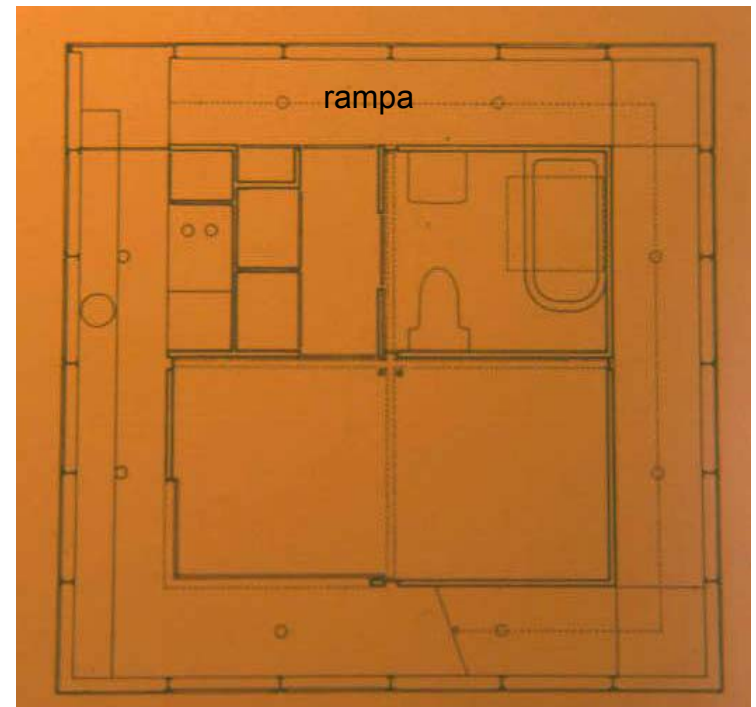
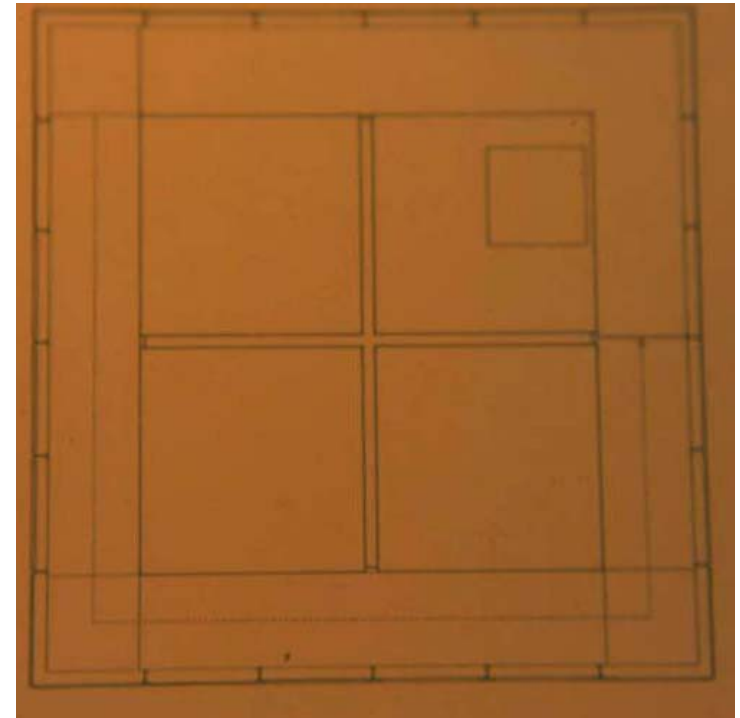



Can you imagine glass house with no privacy? /and no intimacy !

Glass House with glass furniture
2010 |

Talk about taking the glass house to a whole new level! No, this is not a new **Apple Centre** in a far flung region of Norway. This is instead an [amazing house](#) by Italian design team [Santambrogio milano](#), which comes with a set of furniture made entirely from glass. Now, what is it they say about people in glass ?

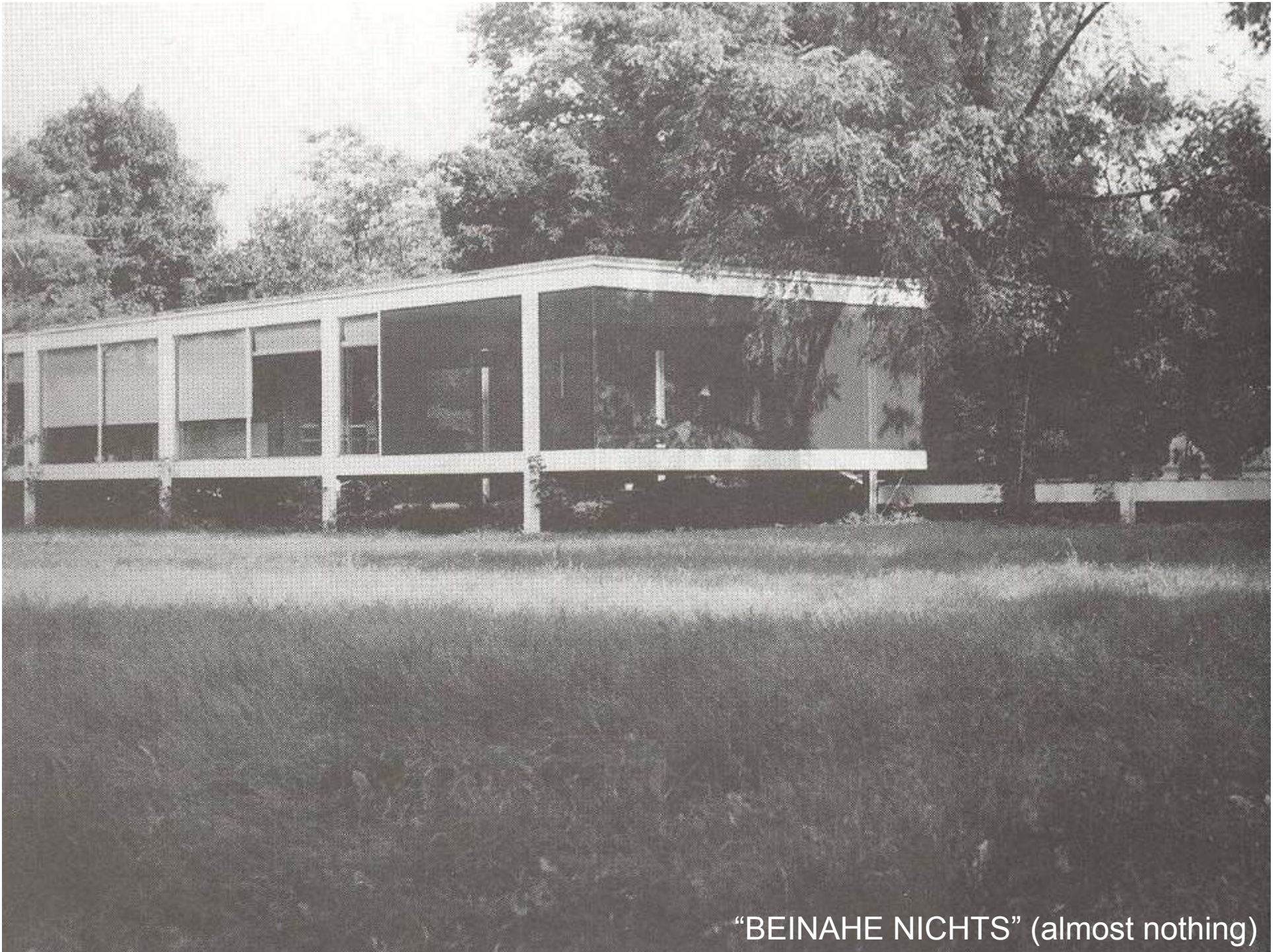

“BEINAHE NICHTS” (almost nothing)

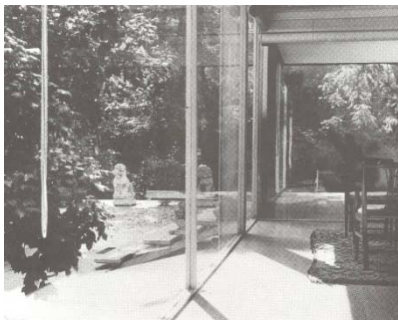
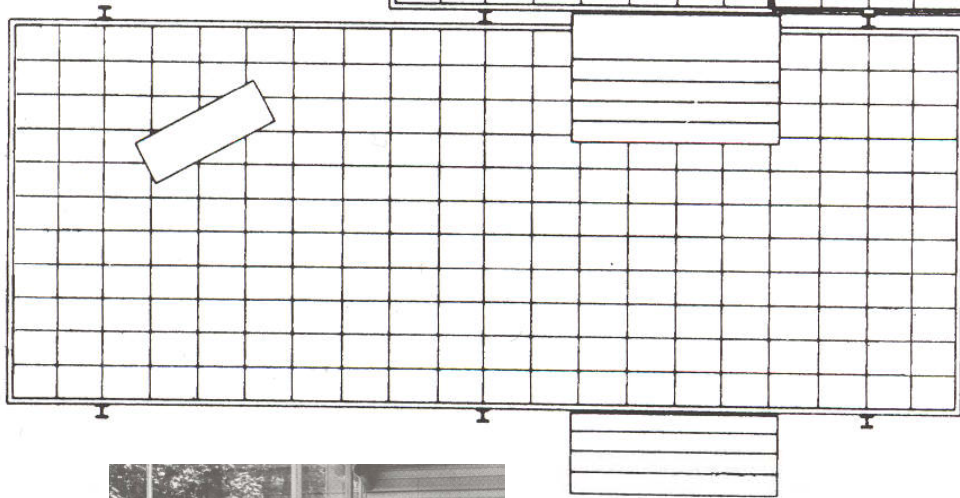
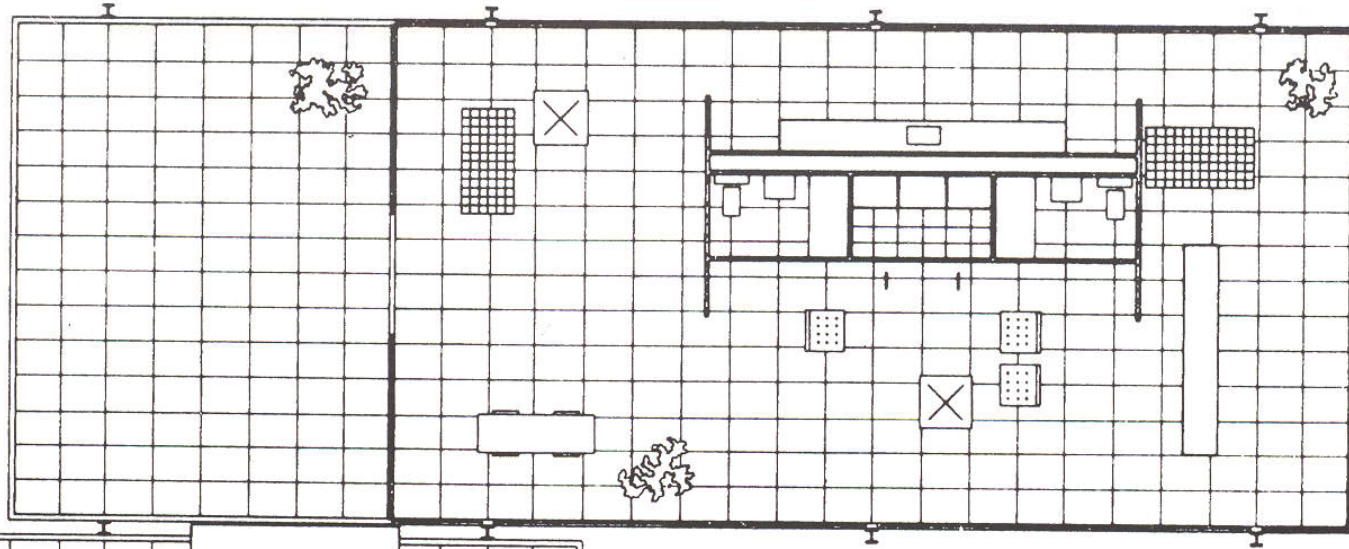

Ludwig Mies Van Der Rohe, Farnsworth House, 1946-51.

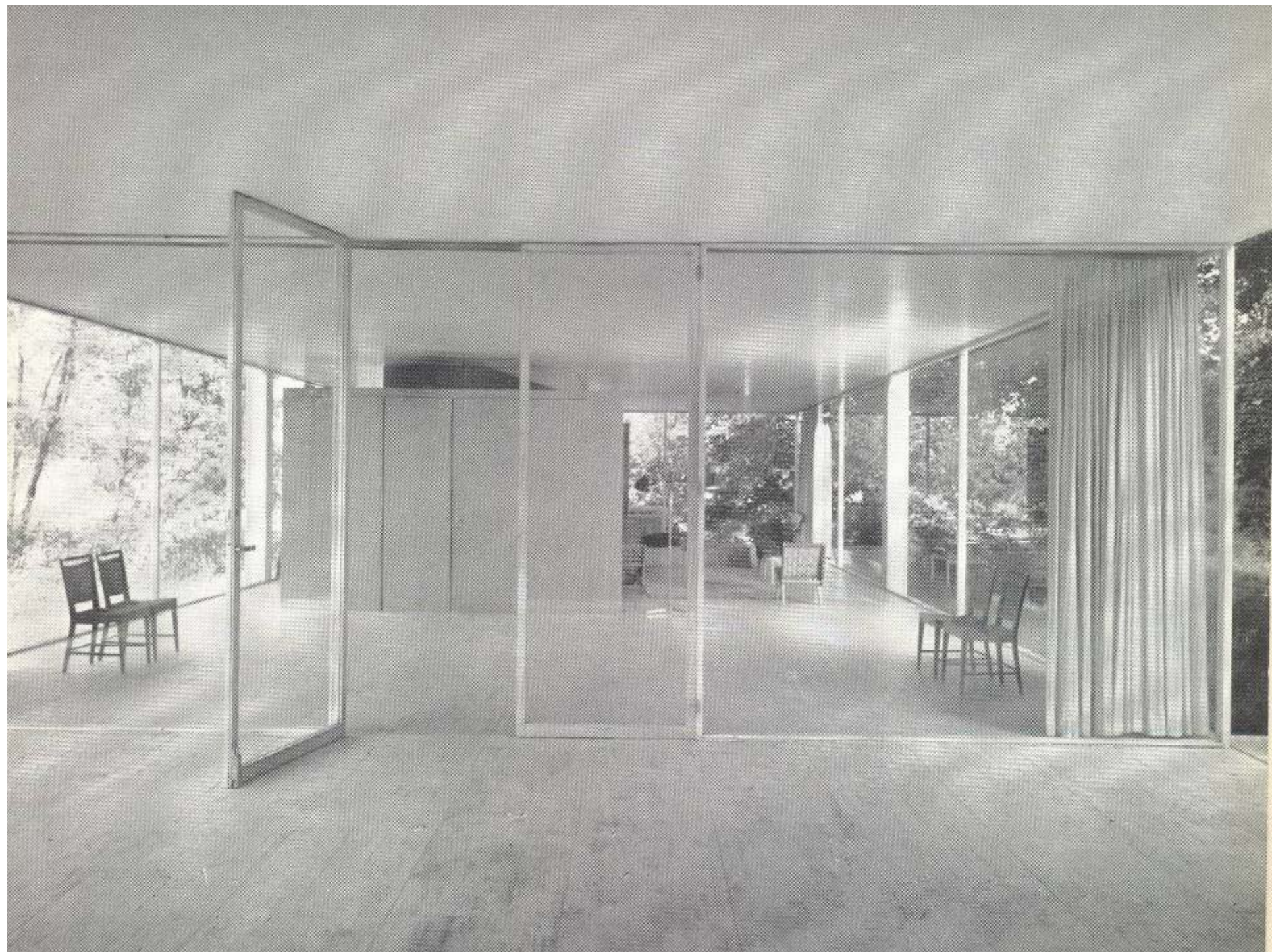

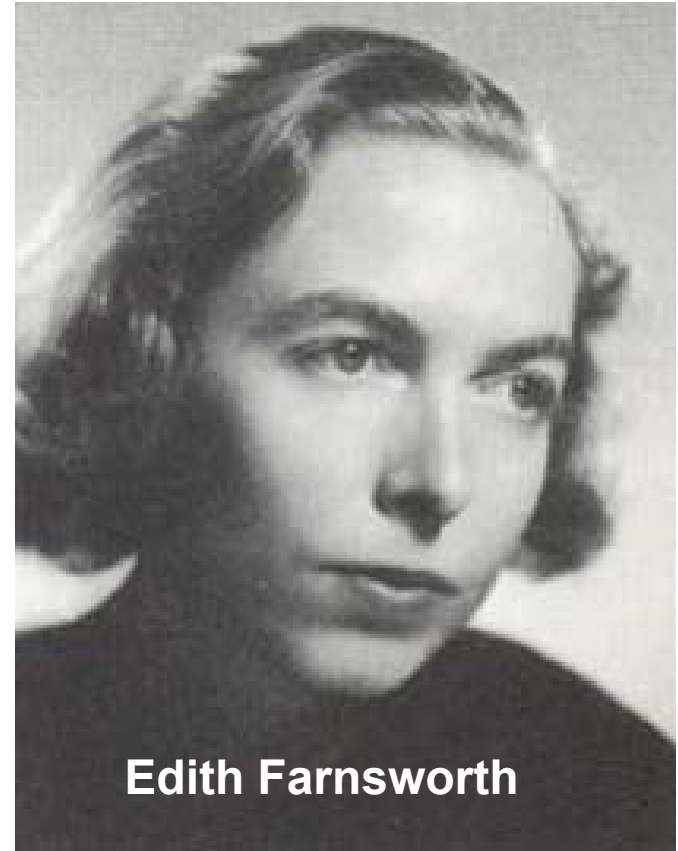

Edith Farnsworth

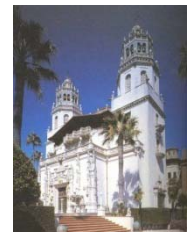
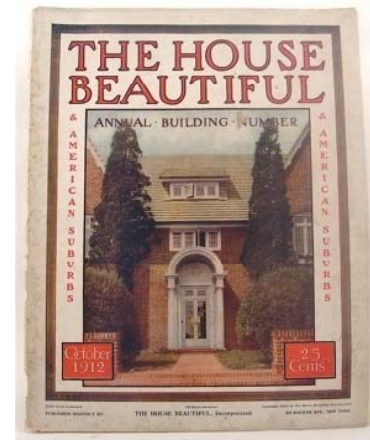



July 1996.

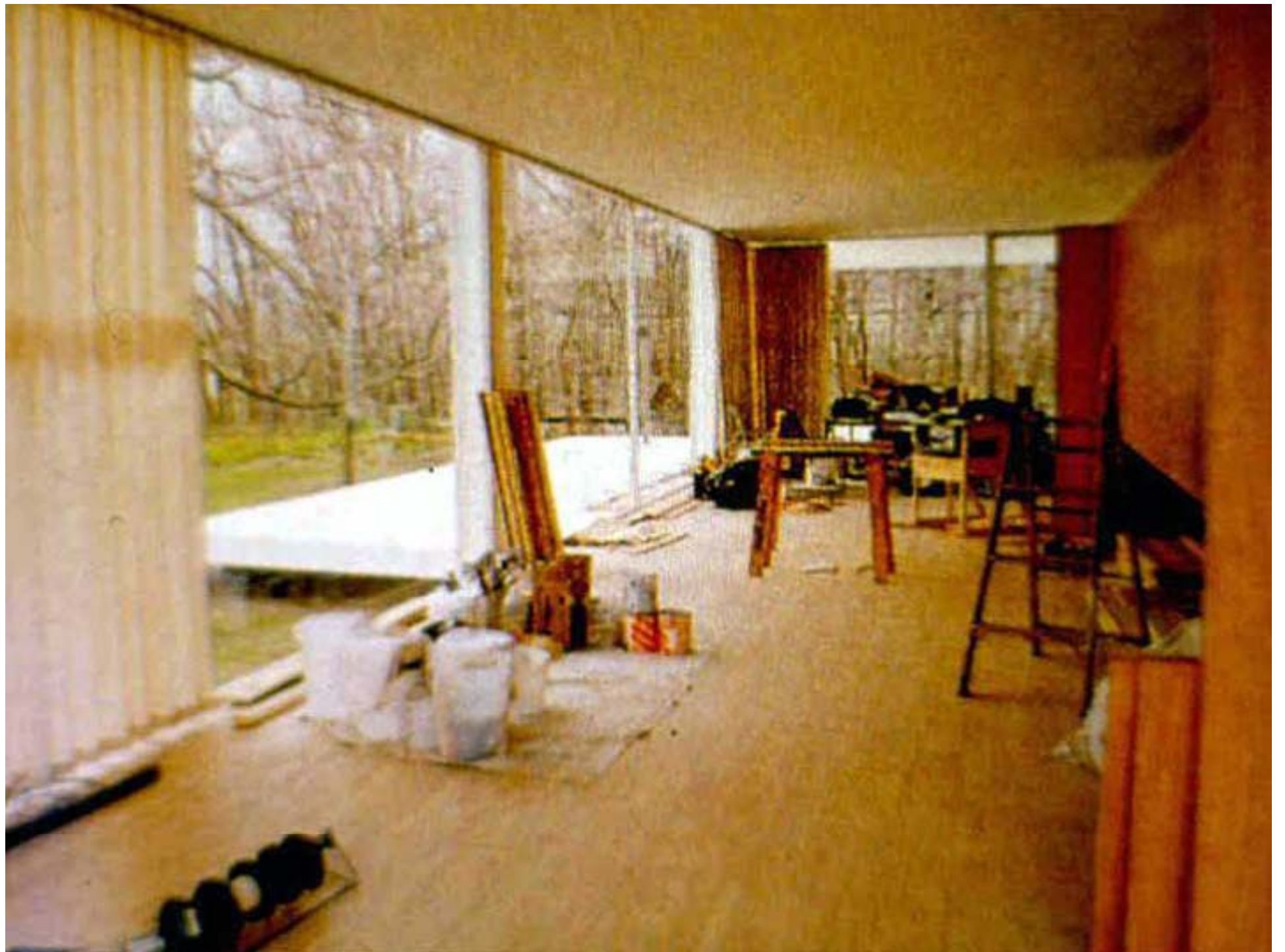

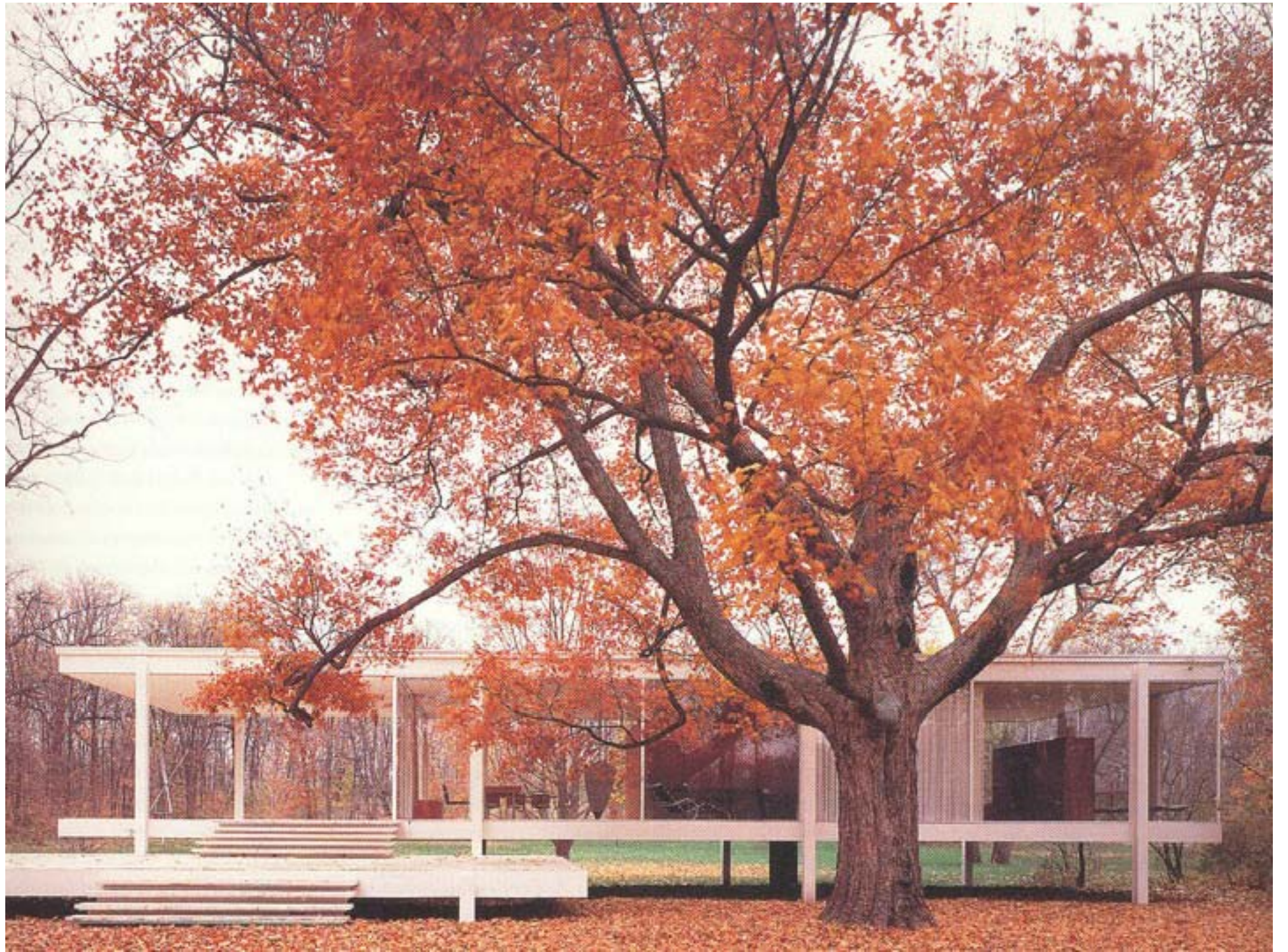



STAKLENKA #2 (ili #1)

V

55

0,618

m

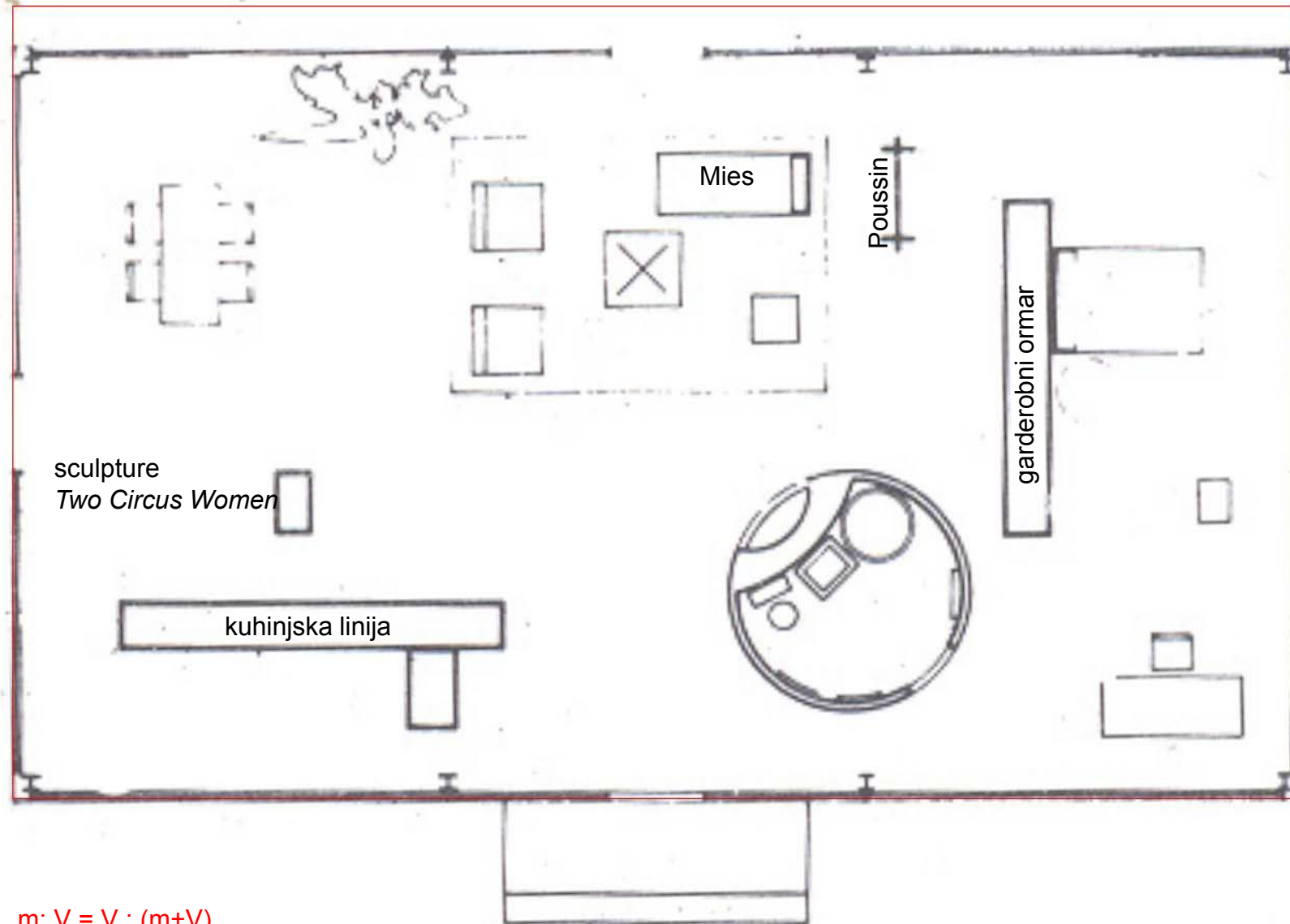

m: V = V : (m+V)

Phillip Johnson, Glass House 1949.

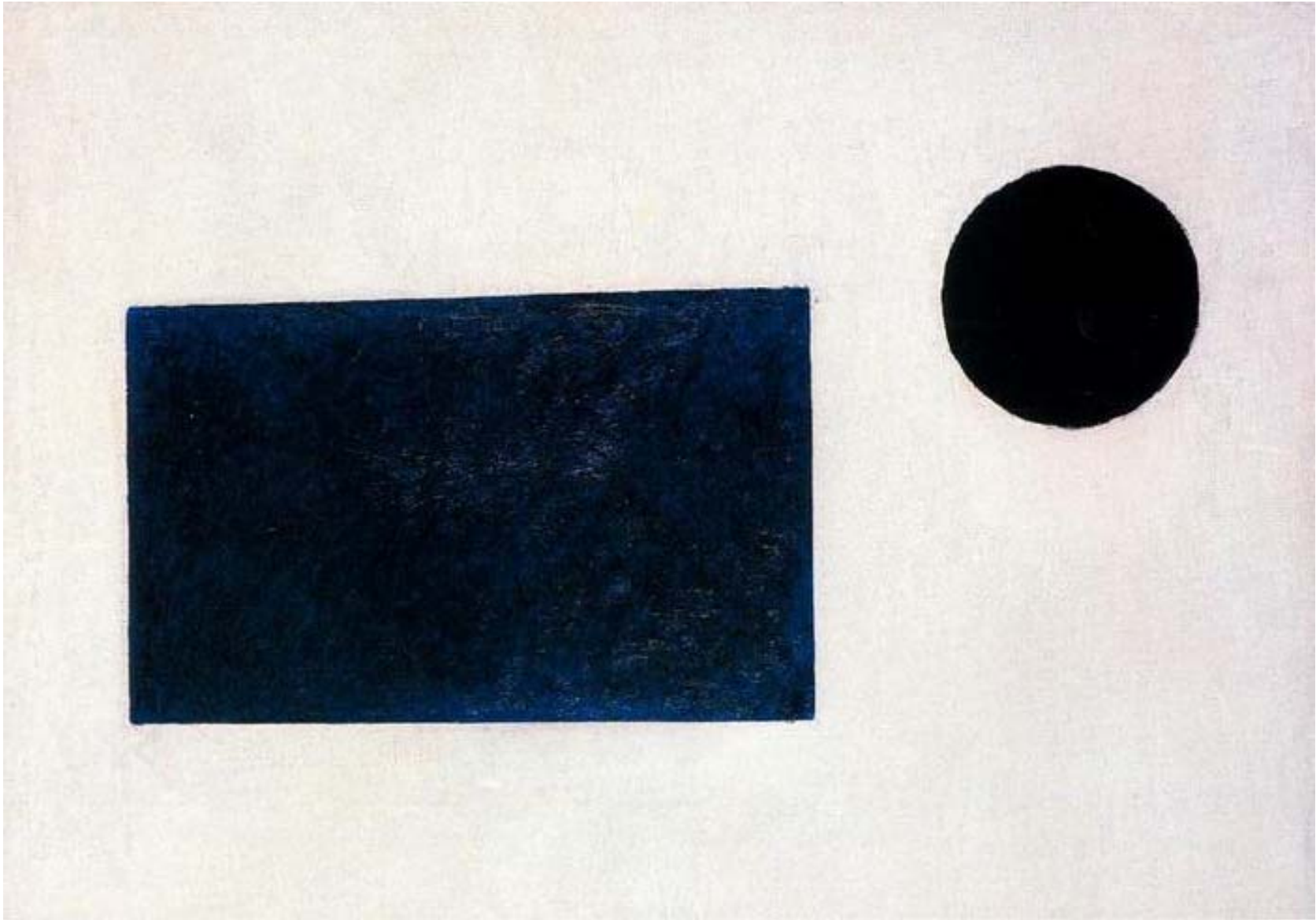

Suprematist Painting. Rectangle and Circle, Oil by **Kazimir Malevich**

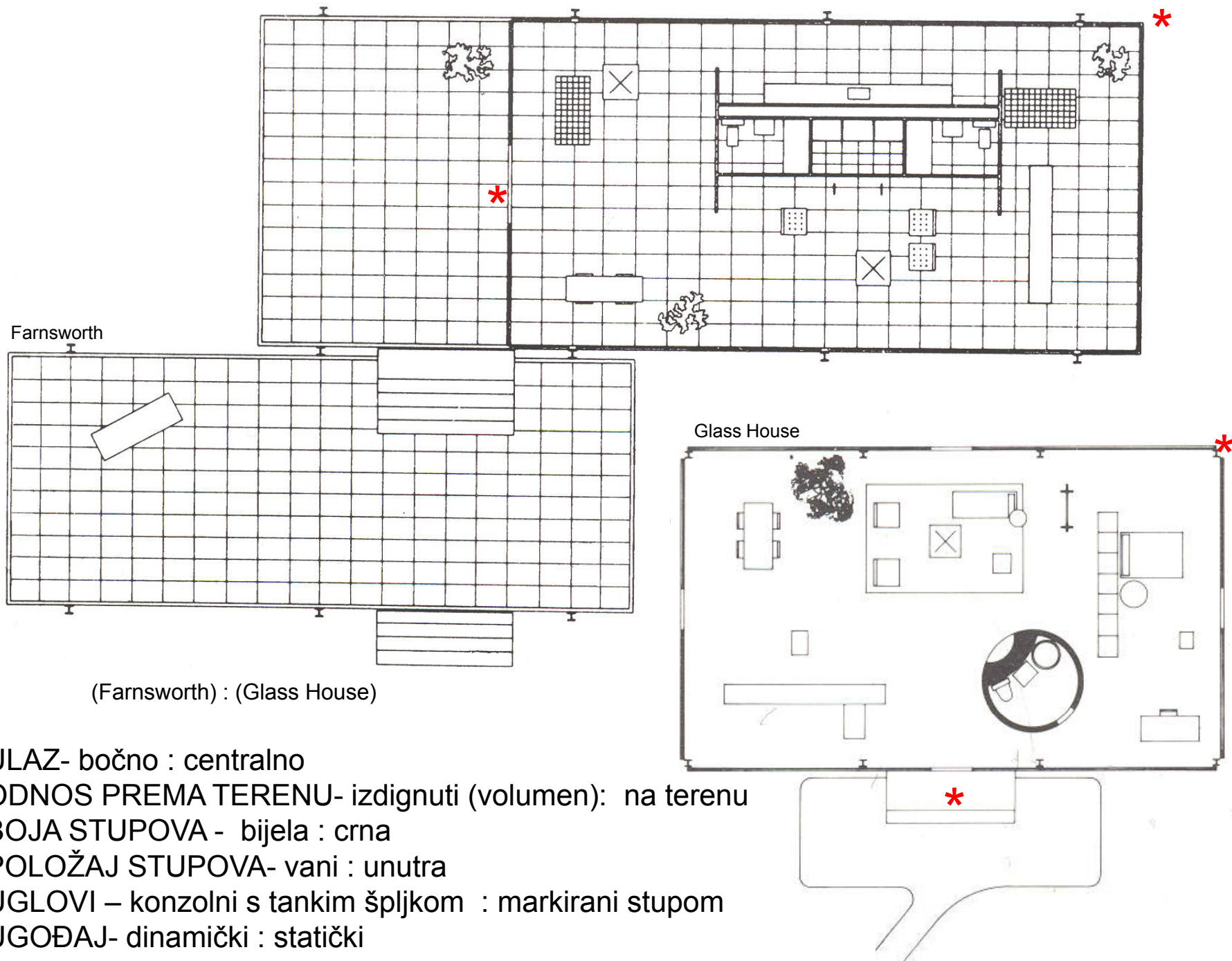

- ULAZ- bočno : centralno
- ODNOS PREMA TERENU- izdignuti (volumen): na terenu
- BOJA STUPOVA - bijela : crna
- POLOŽAJ STUPOVA- vani : unutra
- UGLOVI – konzolni s tankim špljkom : markirani stupom
- UGOĐAJ- dinamički : statički

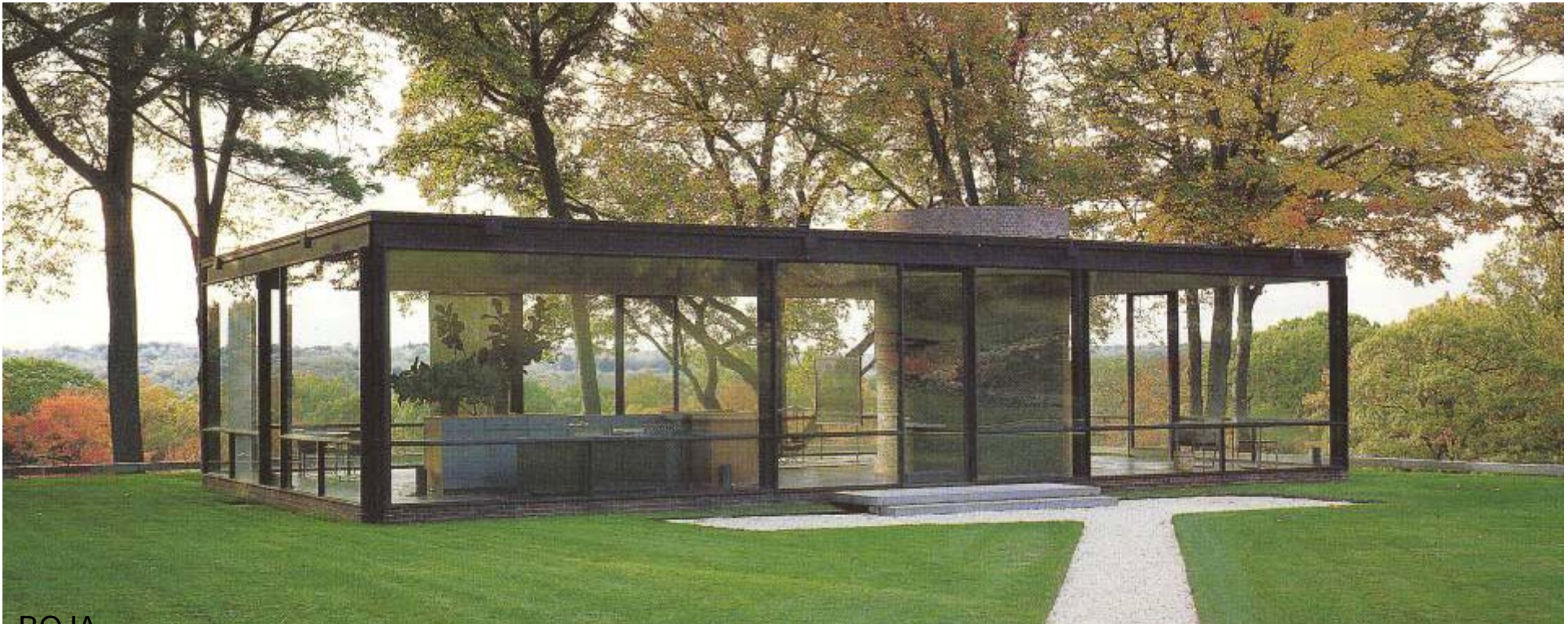

BOJA



Elie Nadelman's
sculpture
Two Circus Women
(1930)
Nicolas Poussin's
Burial of Phocion



Phillip Johnson:
Glass House 1949.

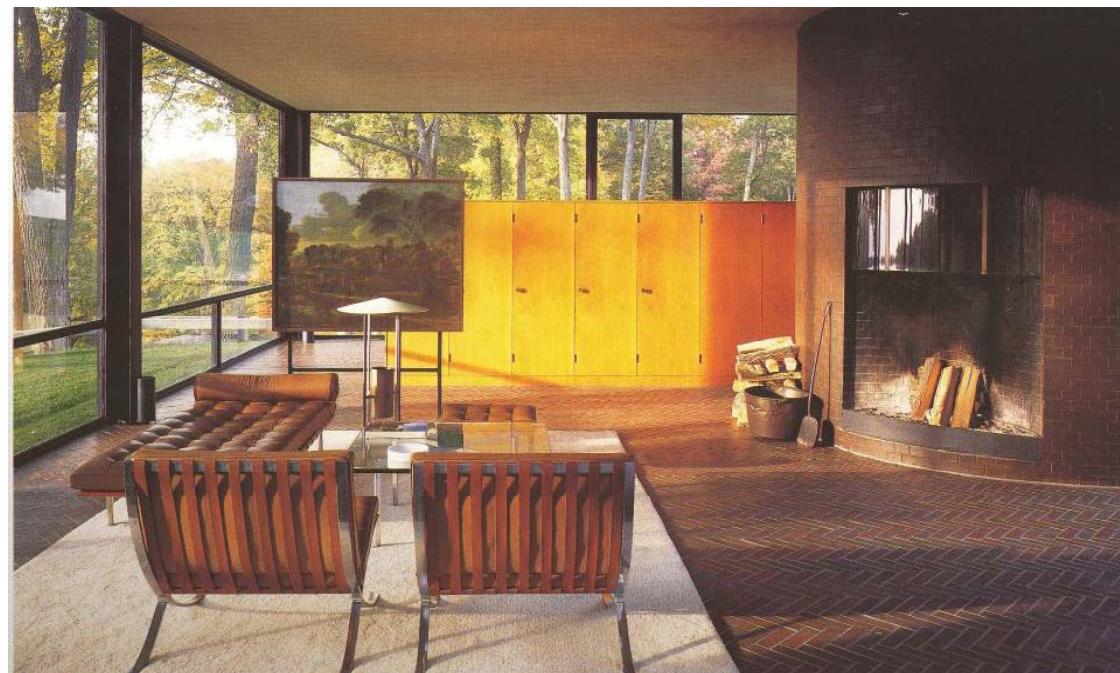



Nicolas Poussin (1594–1665) : *The Burial of Phocion*, 1648.

Philip Johnson The Glass House

- 1 Glashaus
- 2 Gästehaus
- 3 Pavillon im See
- 4 Gemäldegalerie
- 5 Skulpturengalerie
- 6 Bücherturm
- 7 Eingangstor
- 8 Schwimmbecken
- 9 Besucherpavillon

0 feet 100 north

Dennis O'Brien

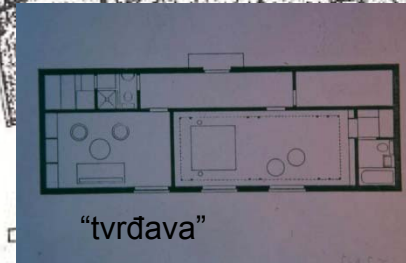
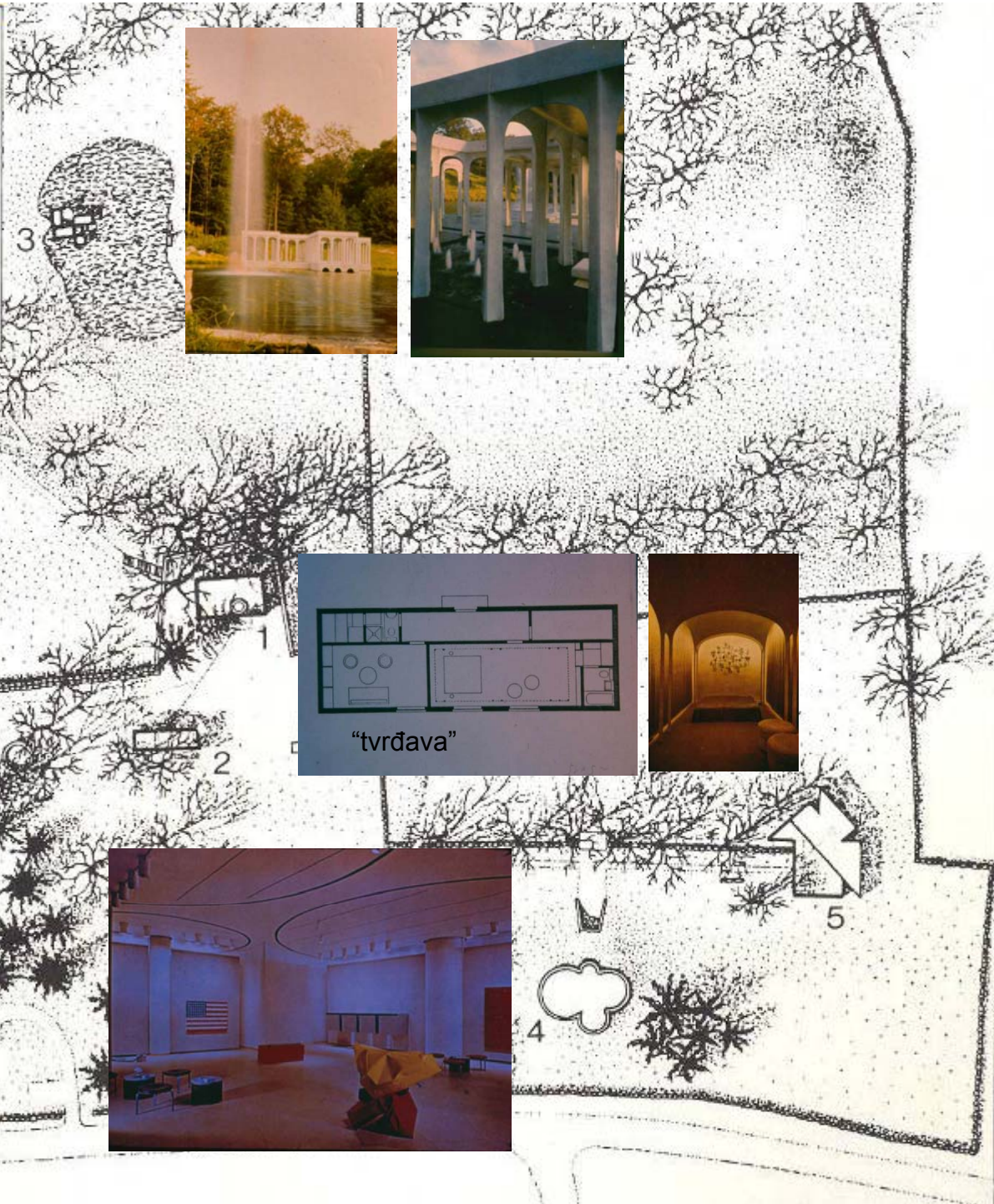

"tvrđava"



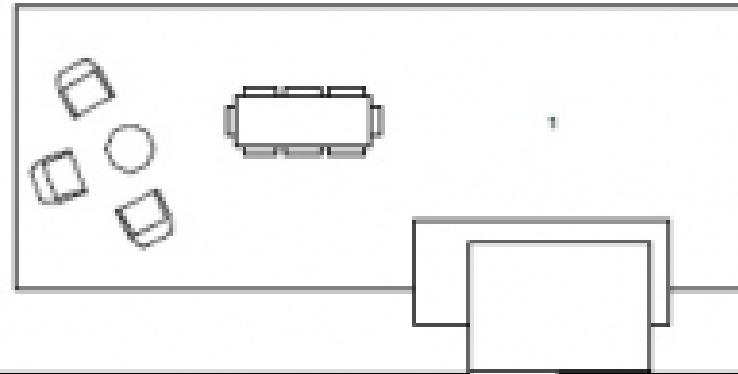

2,000 square-foot
=approx.

187 Square meters

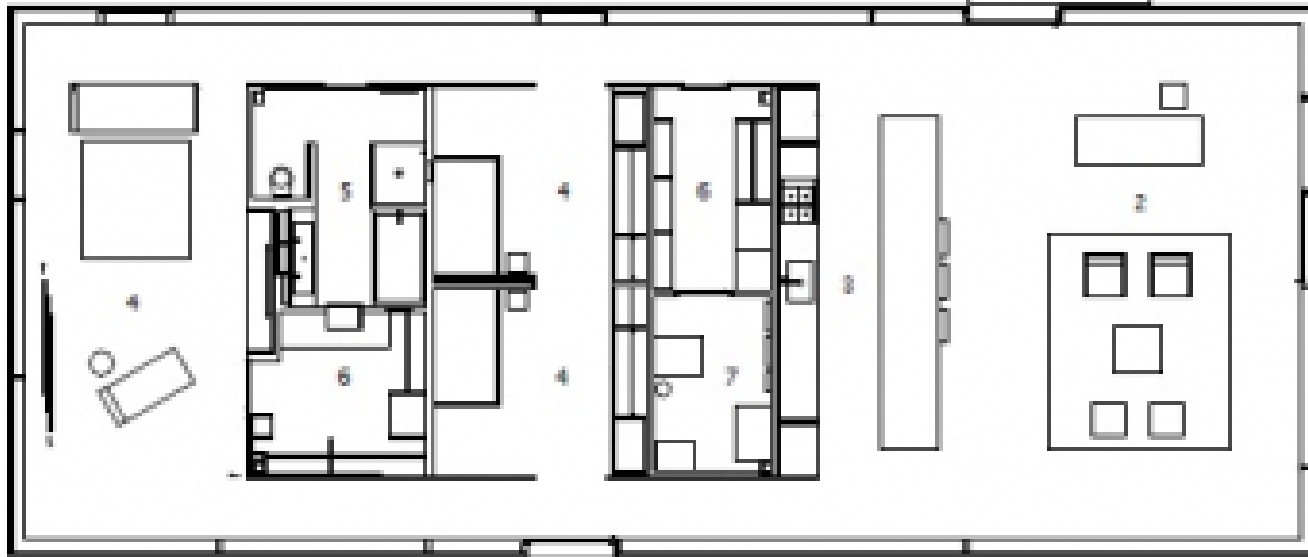

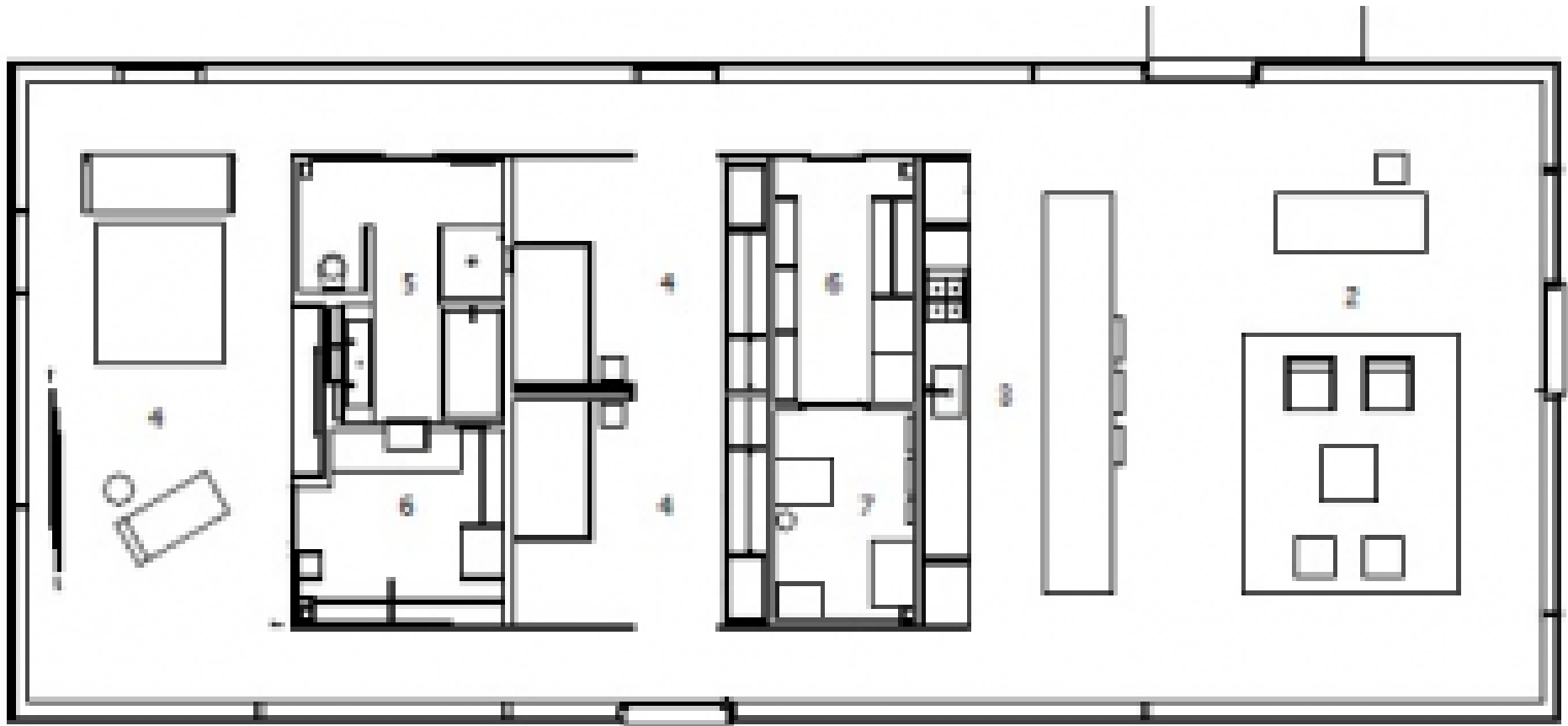

187 Square meters

LM Guest House , Dutchess County, New York, 2012.



Rem Koolhaas: Dutch house, 1993.

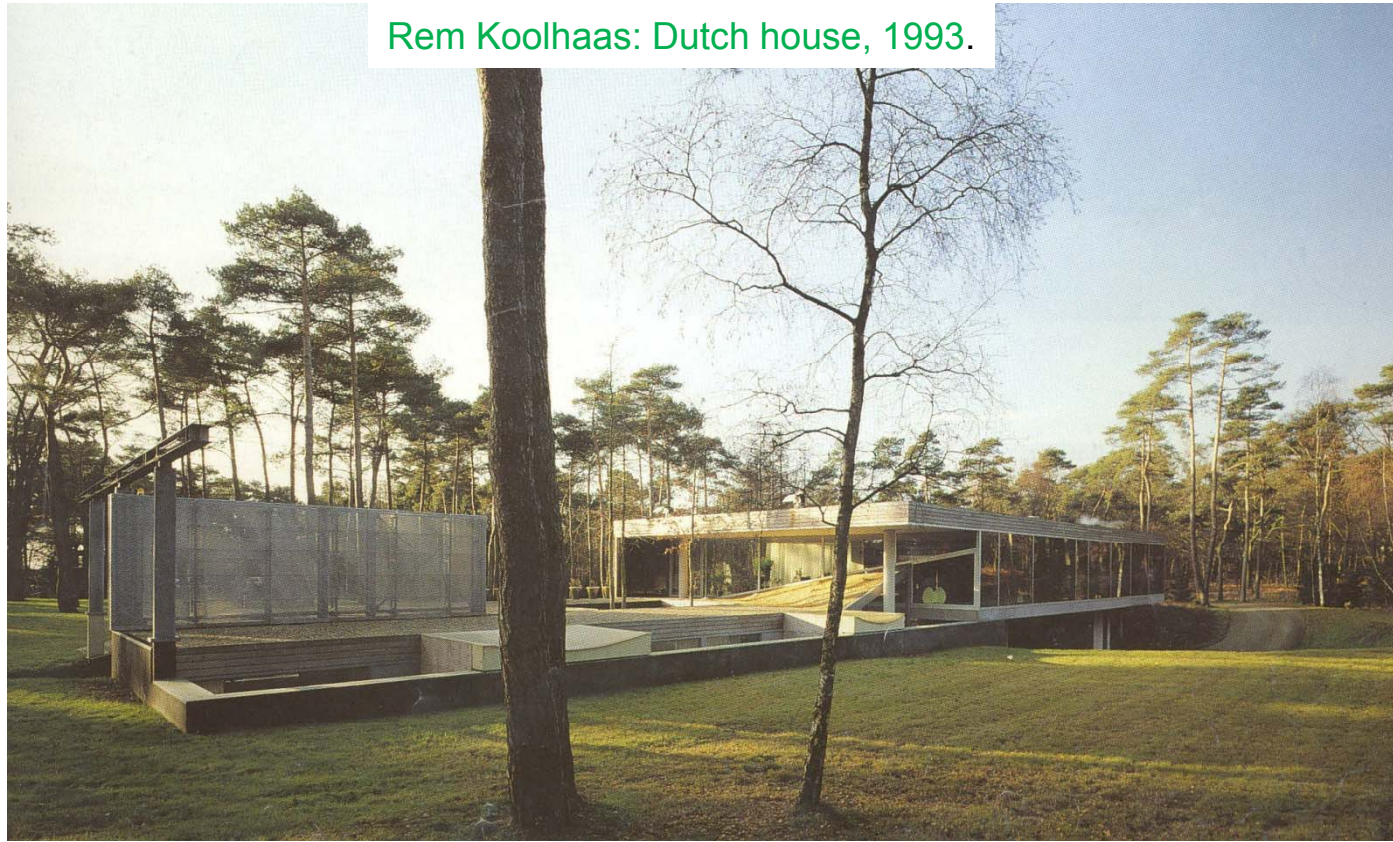

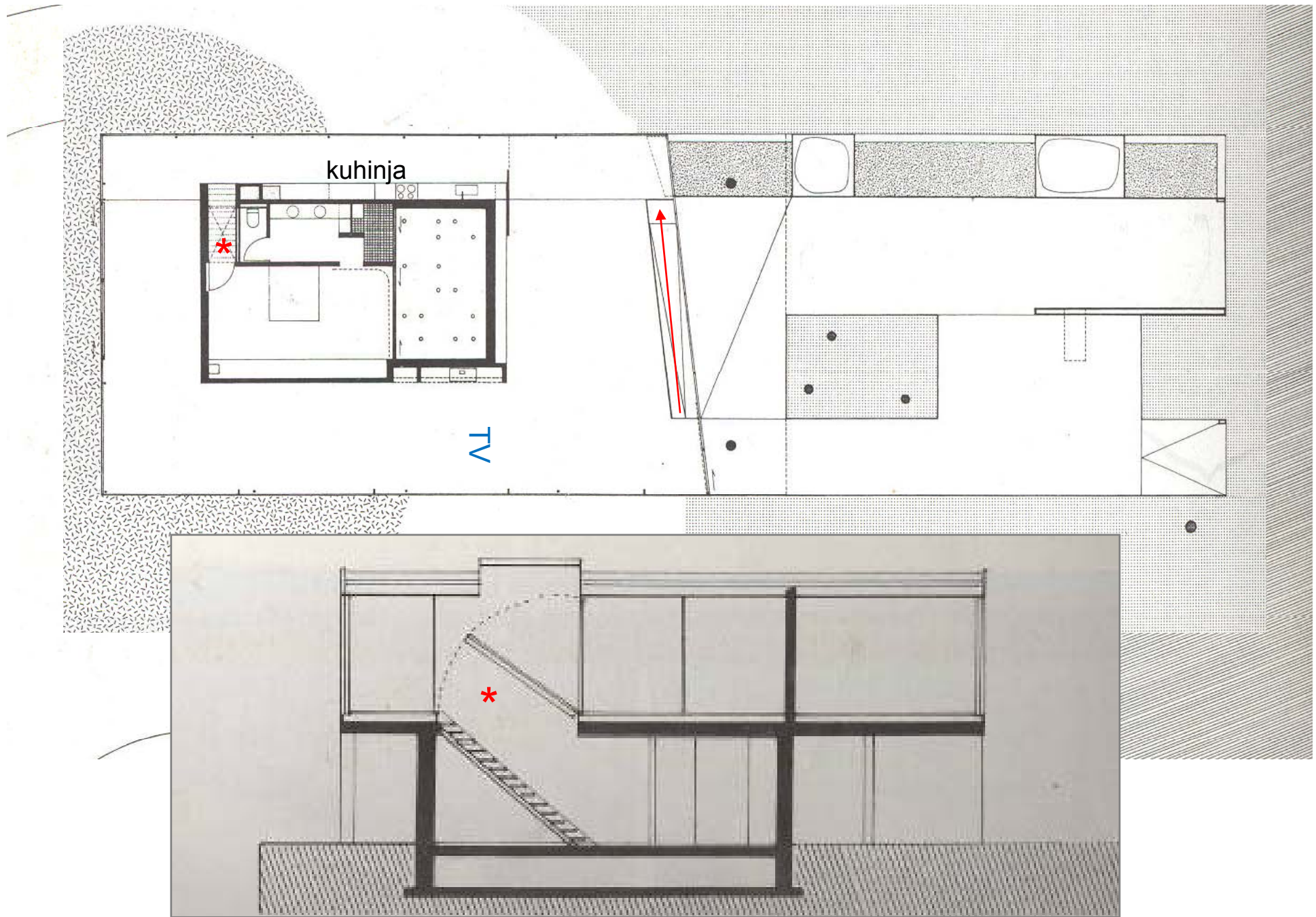

Rem Koolhaas: Dutch house, 1993.

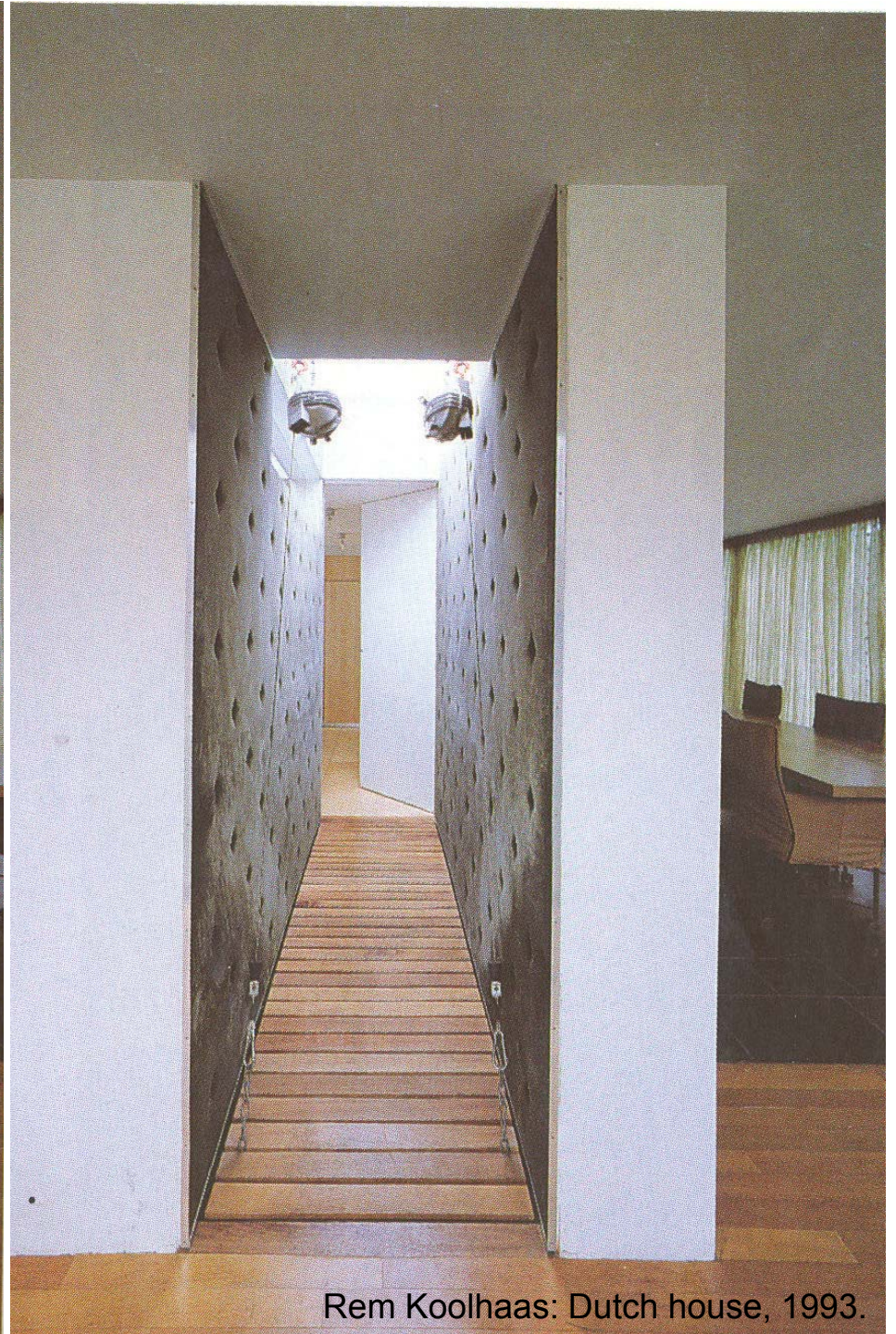

Rem Koolhaas: Dutch house, 1993.

rijetko pojavljivanje Mr.TVa –iako u vrlo neobičnom aranžmanu (prostorno disfunkcionalnom, barem za dva TV “gledaoca”)!



Rem Koolhaas: Dutch house, 1993.

The photograph captures a minimalist interior space. A prominent feature is a ramp with a dark, textured surface that leads up to a higher level. The walls are clad in light-colored wood panels, creating a warm, natural atmosphere. The ceiling is a flat, light grey. In the background, a window with white curtains allows natural light to filter into the space. The overall design is clean and functional, emphasizing geometric forms and material textures.

rampa bez ograde i rukohvata
(za starije otežano –za djecu opasno)

Rem Koolhaas: Dutch house, 1993.

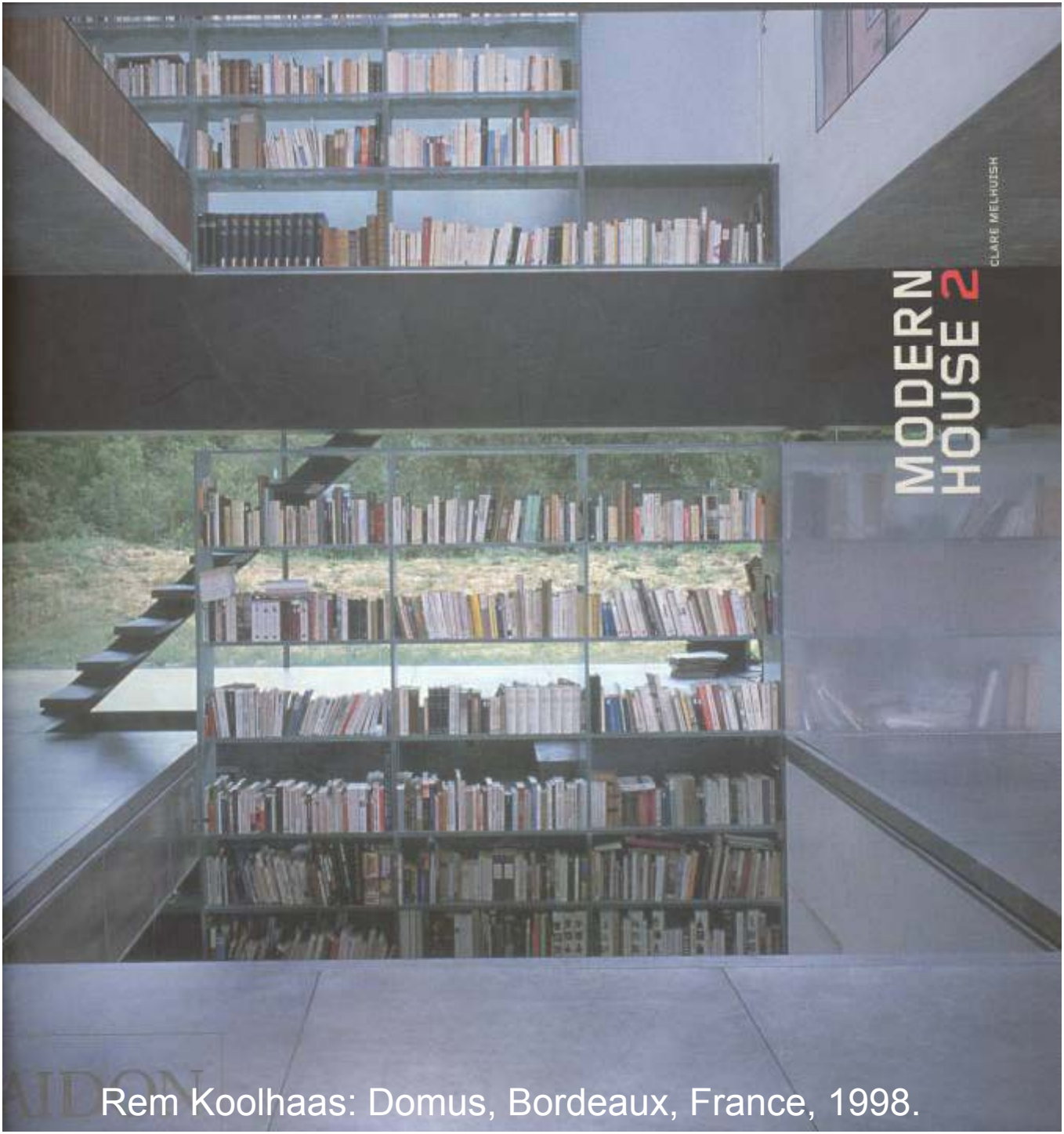

Rem Koolhaas: Domus, Bordeaux, France, 1998.

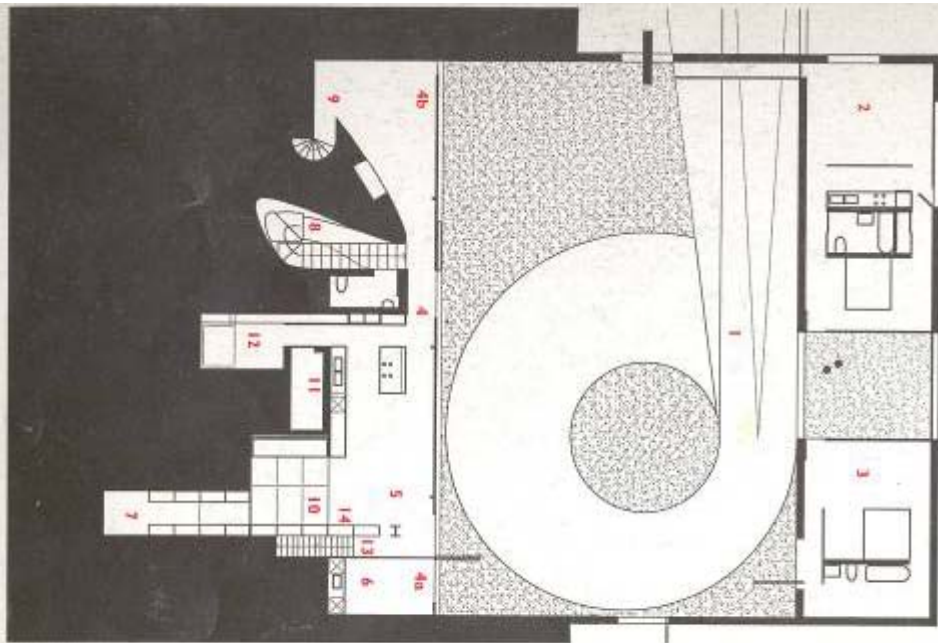

Niveau bas

- 1, mmepe d'occeci
- 2, mndem des pndem
- 3, chndem d'ndm
- 4, entree pndem
- 4a, entree de service
- 4b, entree des enfndm
- 5, cndem
- 6, buandem
- 7, cove à vnm
- 8, escde pndem
- 9, sdem, sdem
- 10, pndem mdem
- 11, lndem
- 12, ndem
- 13, escde de service
- 14, mndem
- 15, escde d'occeci
- 16, sde
- 17, ndem
- 18, ndem
- 19, ndem
- 20, ndem
- 21, ndem
- 22, ndem
- 23, ndem
- 24, ndem
- 25, ndem
- 26, ndem
- 27, ndem
- 28, ndem
- 29, ndem
- 30, ndem
- 31, ndem

Villa Dal'Ava ima rampu, Dutch House ima rampu-
 Kuća za invalida nema rampu) Ima dizalo, platformu-radni prostor



Coupe longitudinale

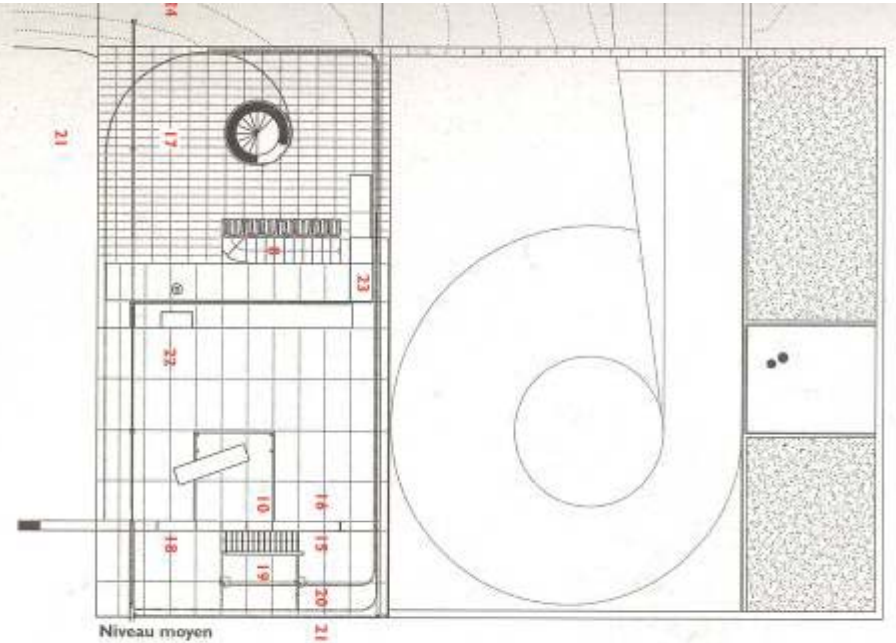

Niveau moyen

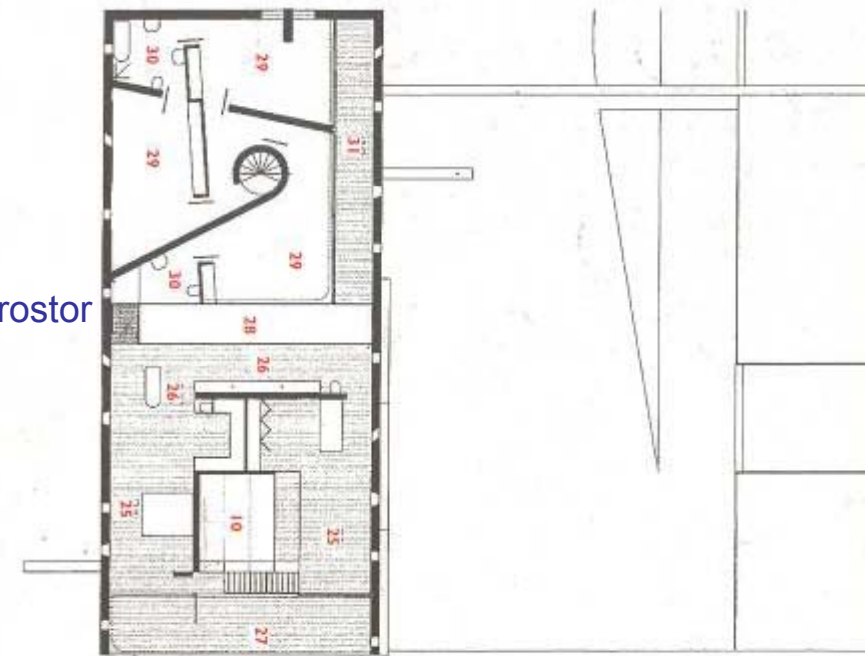

Rem Koolhaas: Domus, Bordeaux, France, 1998.



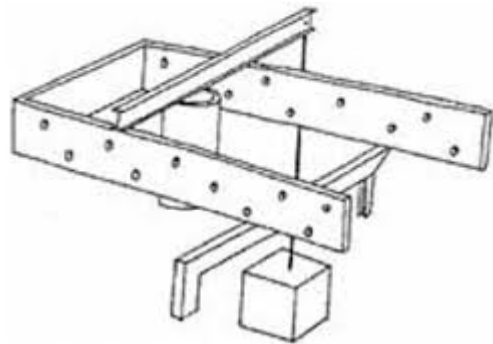
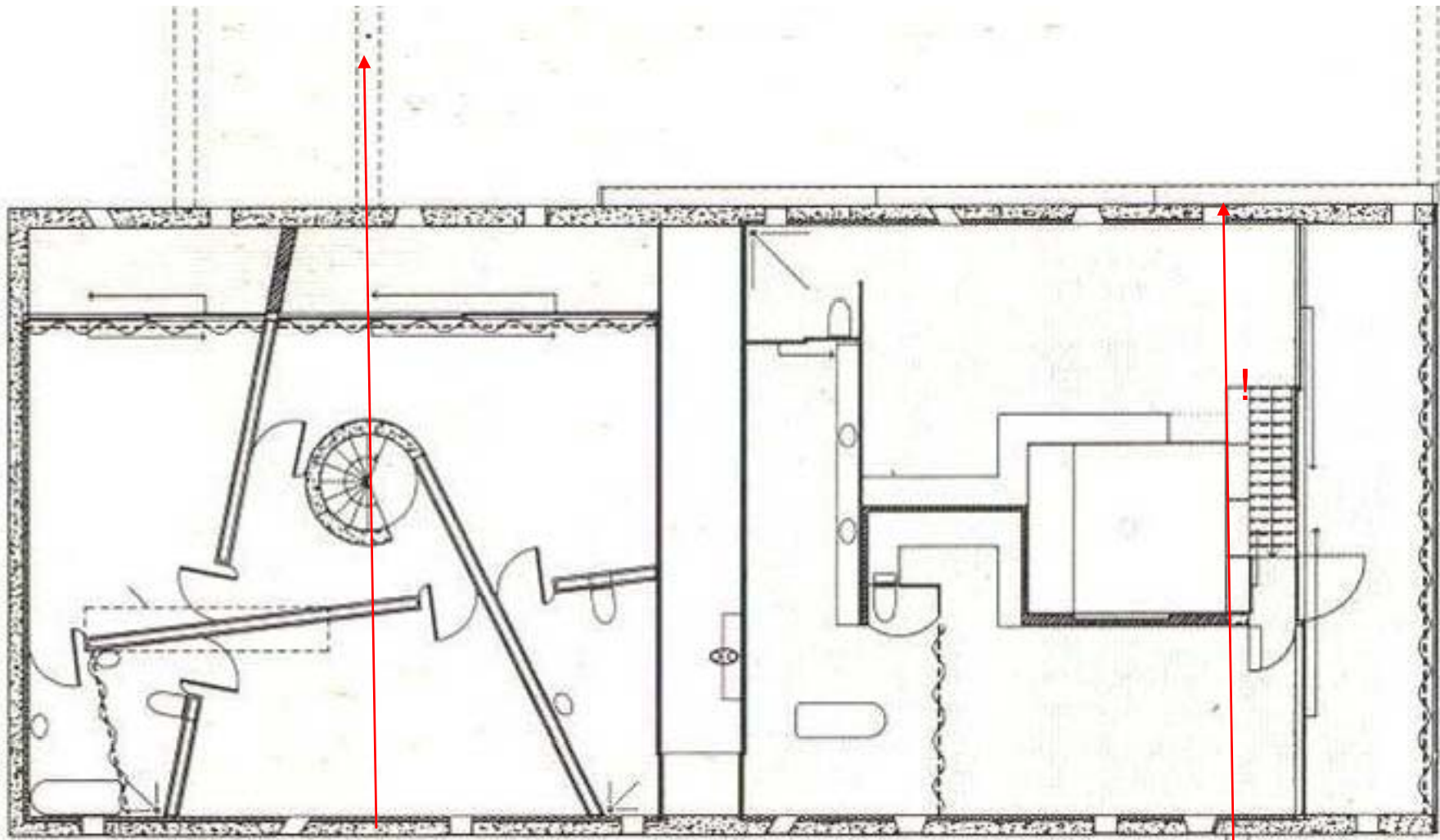

!

Rem Koolhaas: Domus, Bordeaux, France, 1998.

Rem Koolhaas: Domus, Bordeaux, France, 1998.

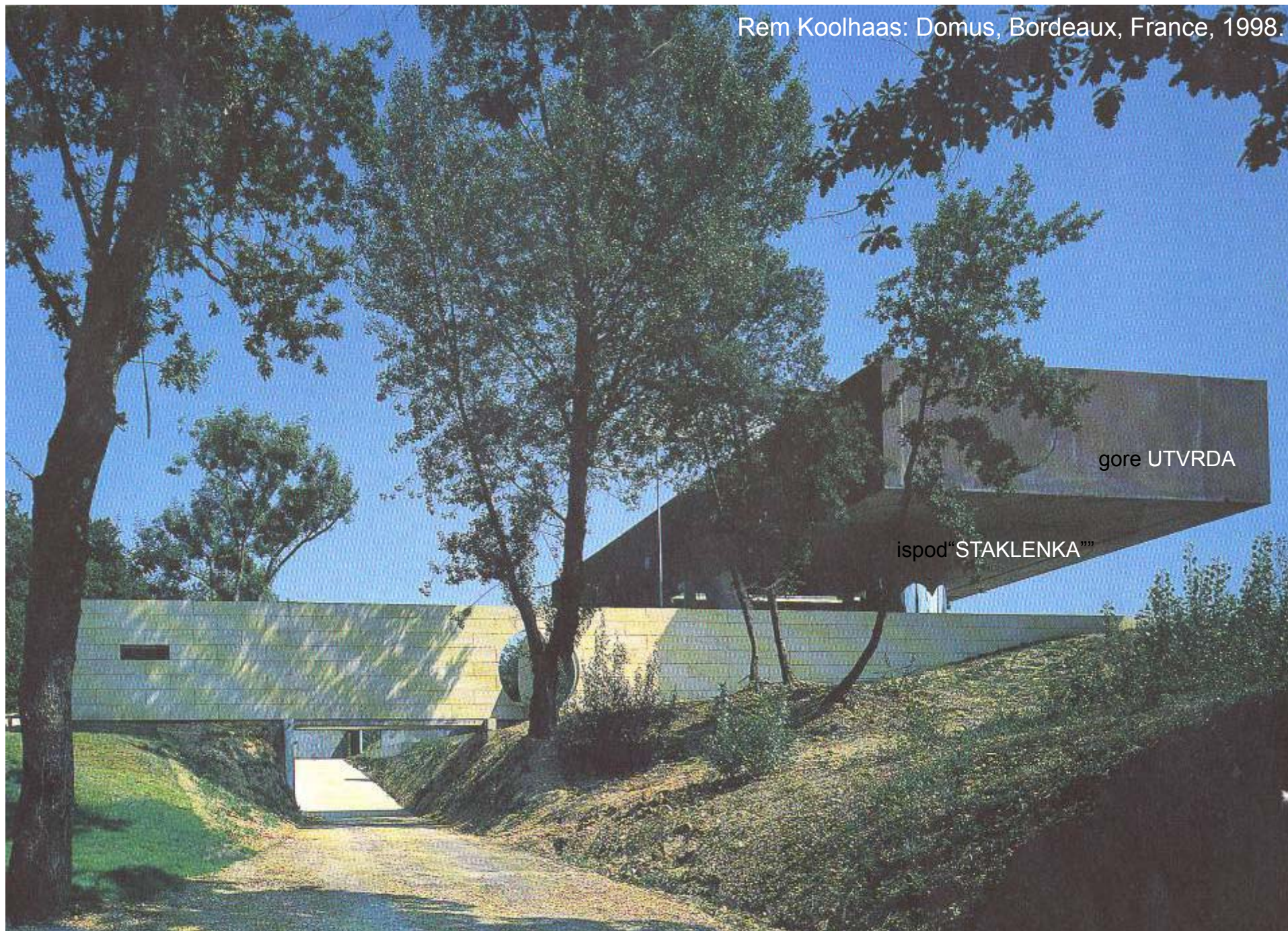

gore UTVRDA

ispod "STAKLENKA"

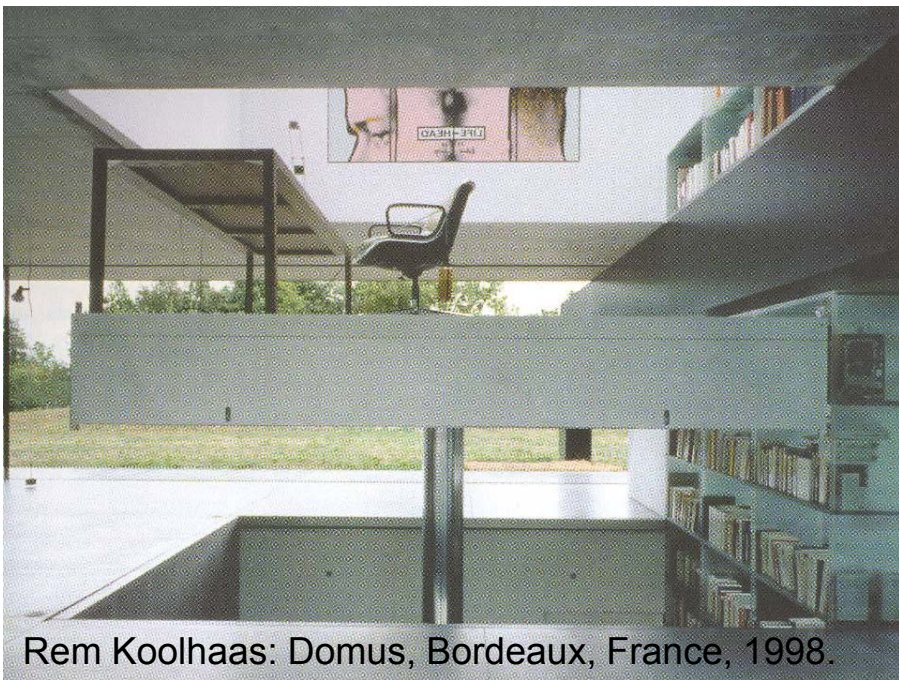
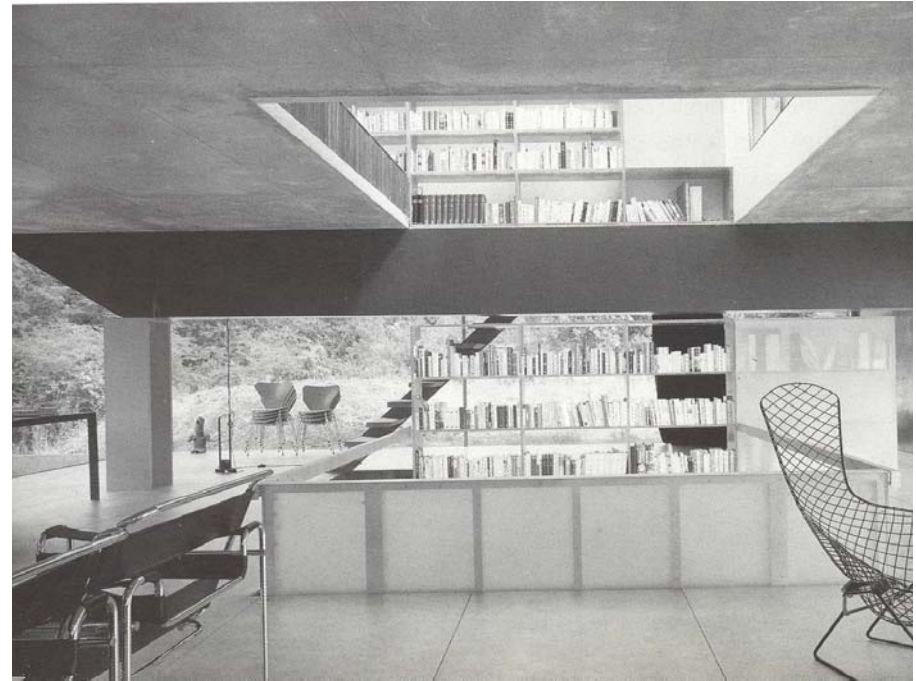

Rem Koolhaas: Domus, Bordeaux, France, 1998.



AUG 3

HAMMER SCREENINGS | TUE | 7PM | BILLY WILDER THEATER

KOOLHAAS HOUSELIFE

HAMMER

An intimate look into the daily life of one of the masterpieces of contemporary architecture of recent years: The House in Bordeaux, designed in 1998 by **Rem Koolhaas / OMA.**

(France, 2008, 58 min. French with English subtitles.
Dirs: Ila Bêka and Louise Lemoine)

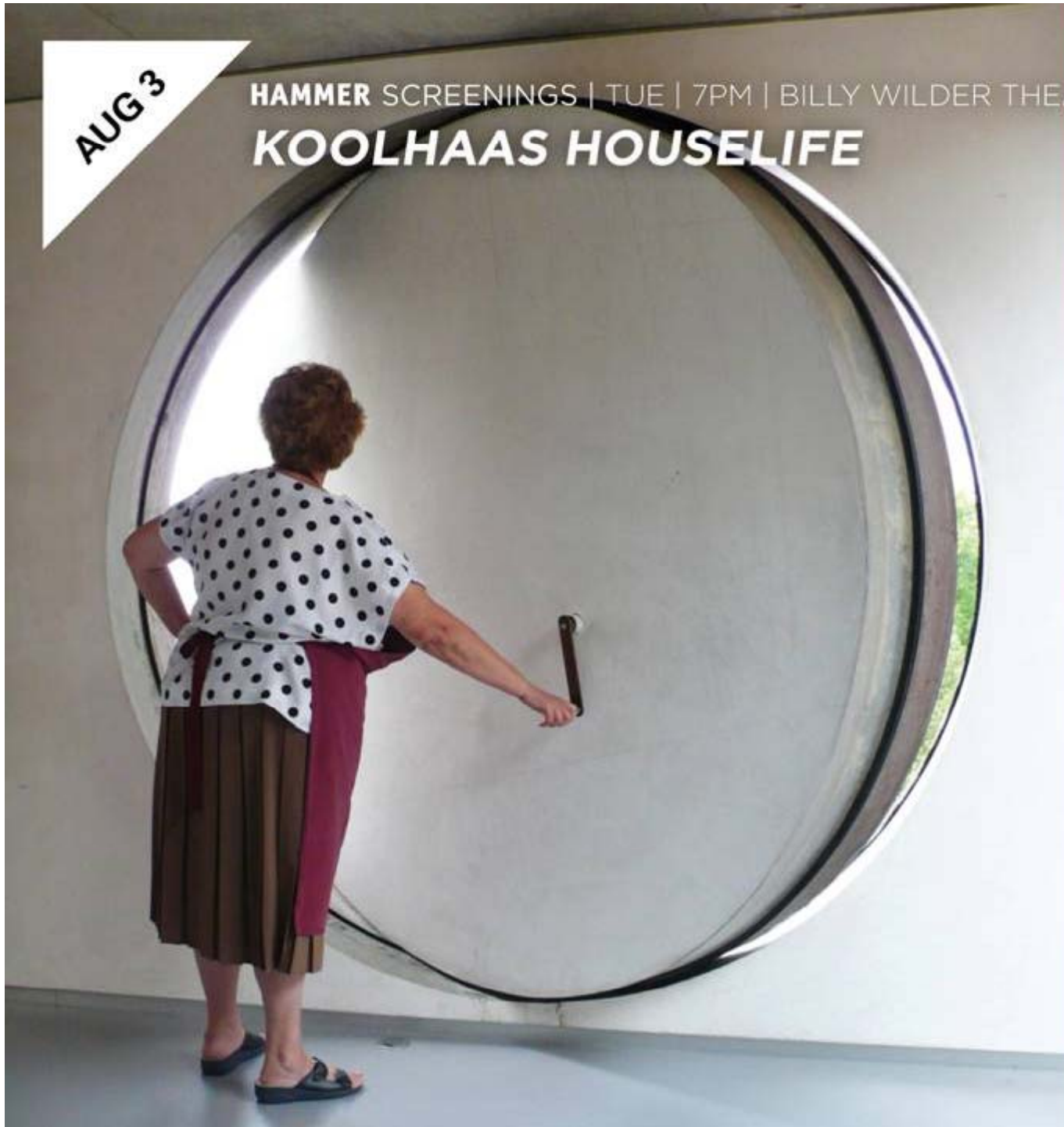

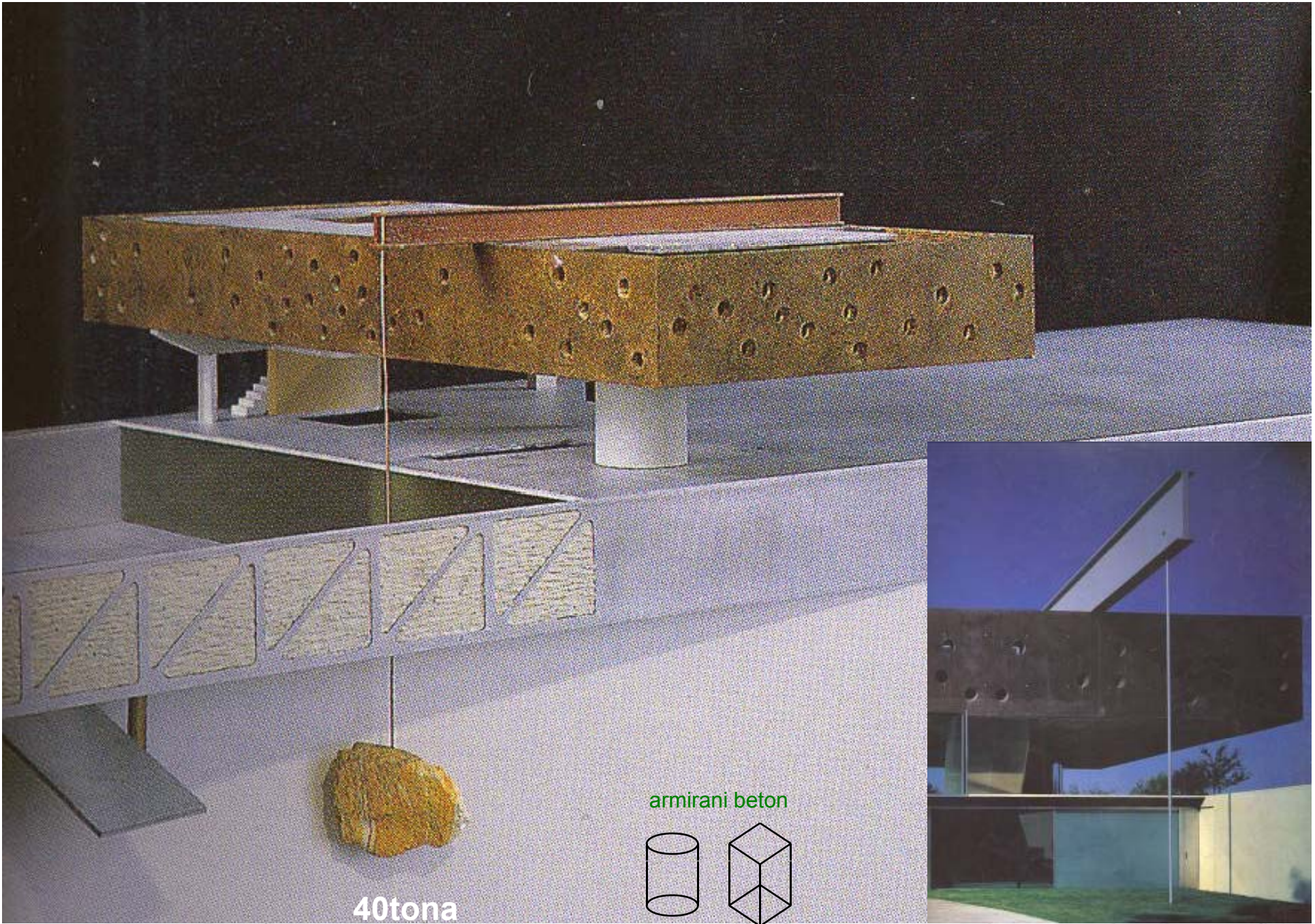

40tona

armirani beton

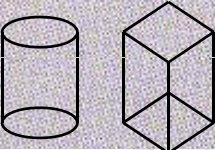



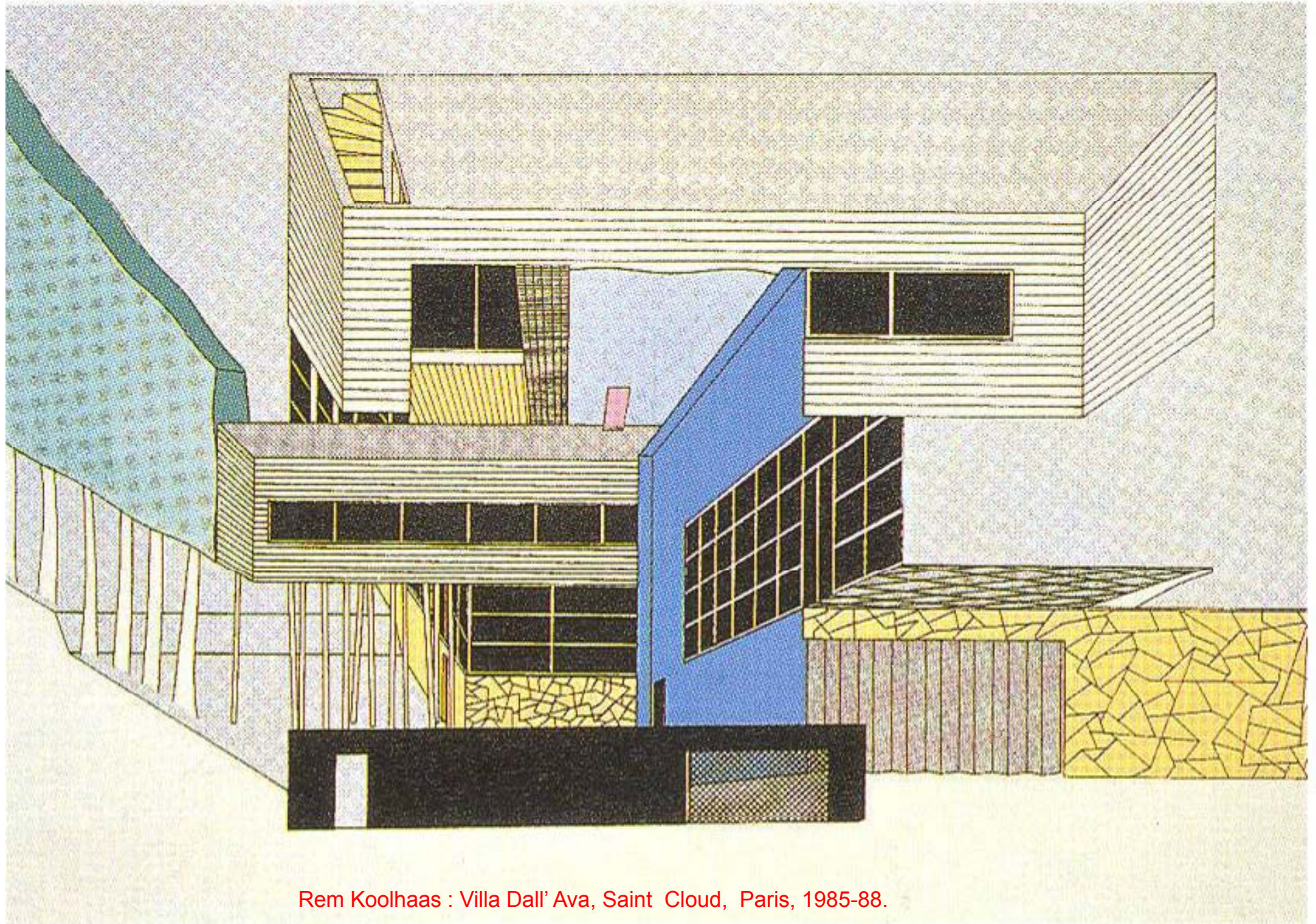

Rem Koolhaas : Villa Dall' Ava, Saint Cloud, Paris, 1985-88.





Can you imagine glass house with no privacy?

Glass House with glass furniture

April 20, 2010 | [New & Cool Architecture](#) | by [Zolton](#)

Talk

about taking the glass house to a whole new level! No, this is not a new Apple Centre in a far flung region of Norway. This is instead an [amazing house](#) by Italian design team [Santambrogio milano](#), which comes with a set of furniture made entirely from glass. Now, what is it they say about people in glass



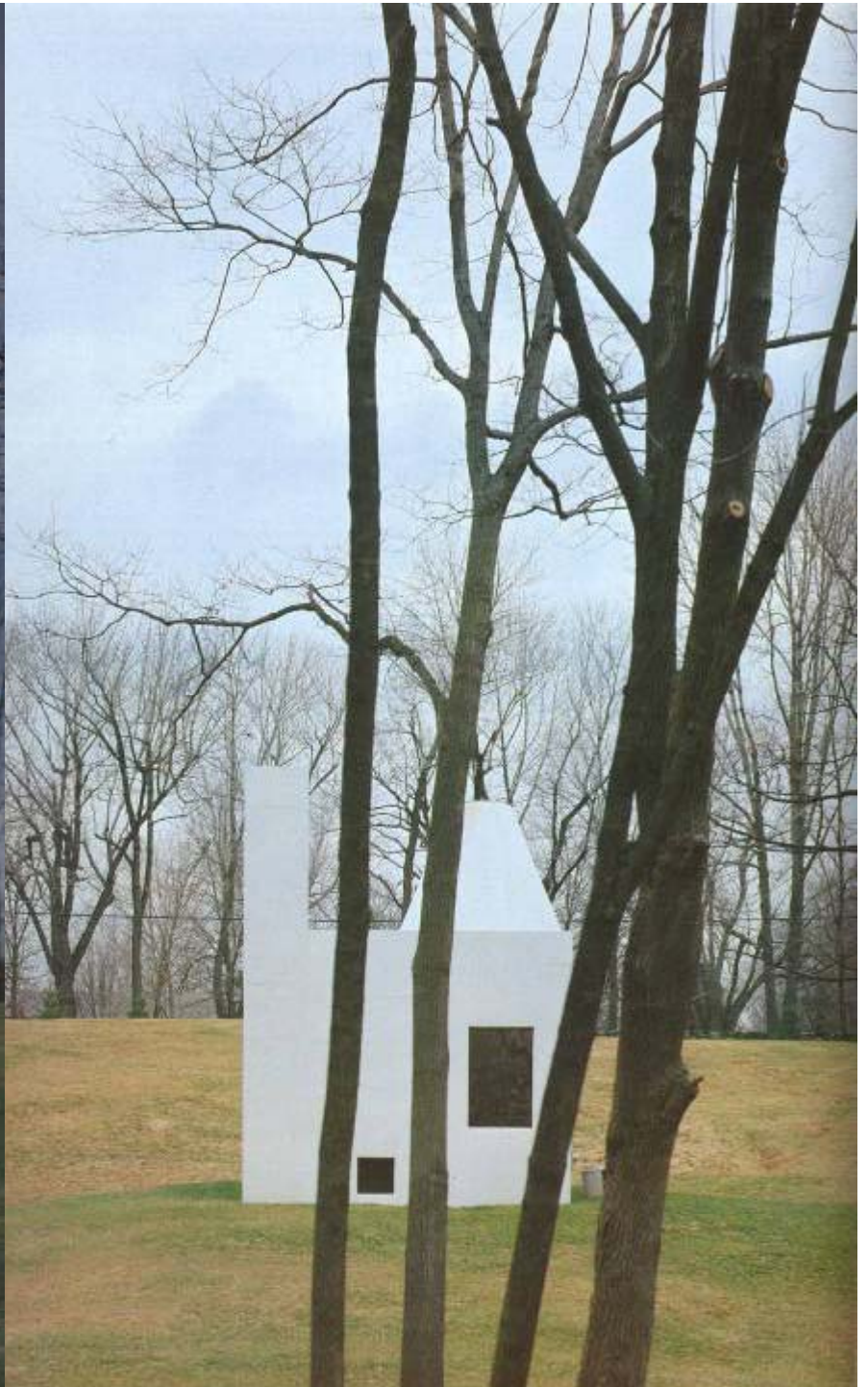

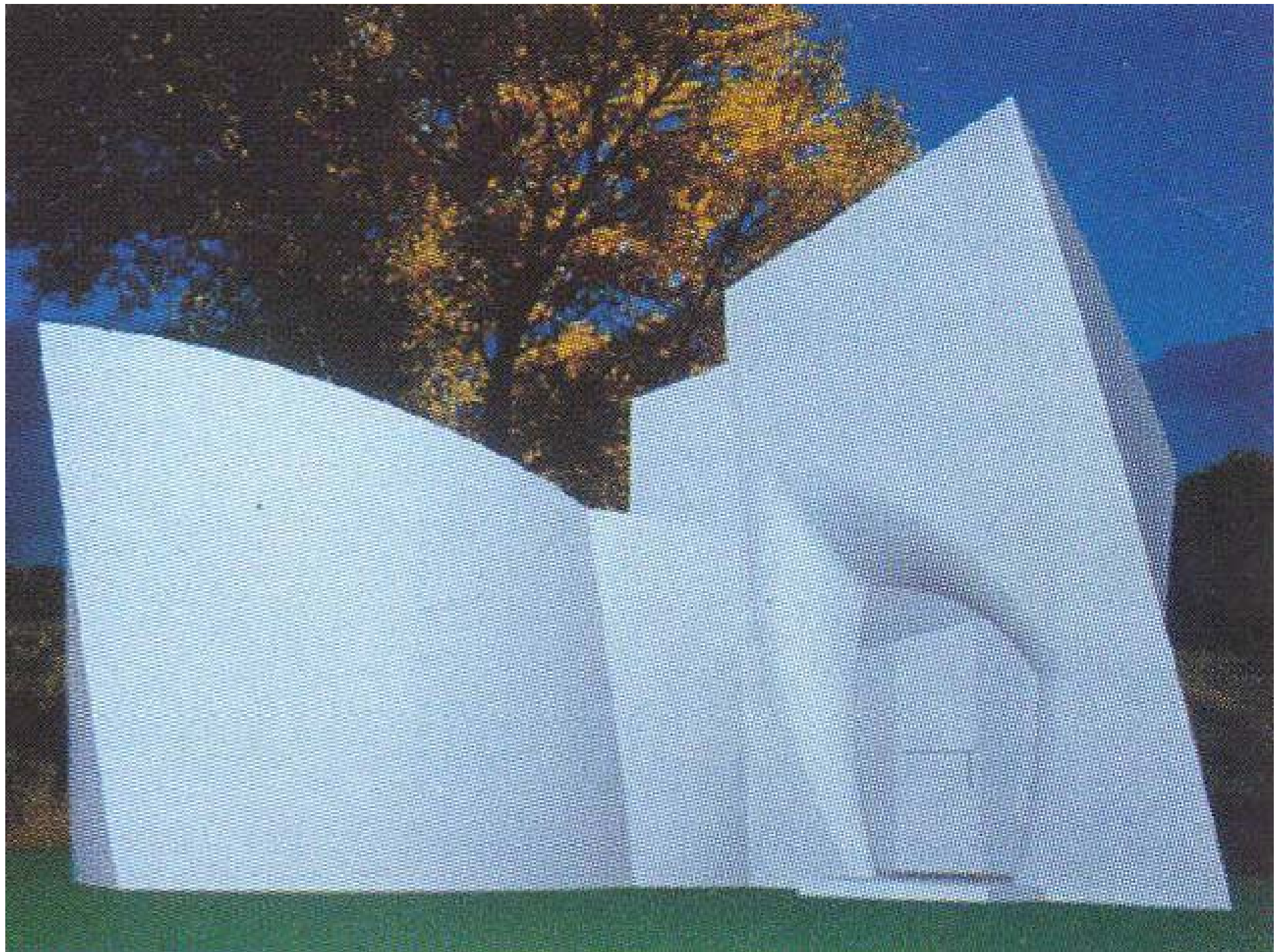



Werner Sobek: R128



Phillip Johnson: Guest House

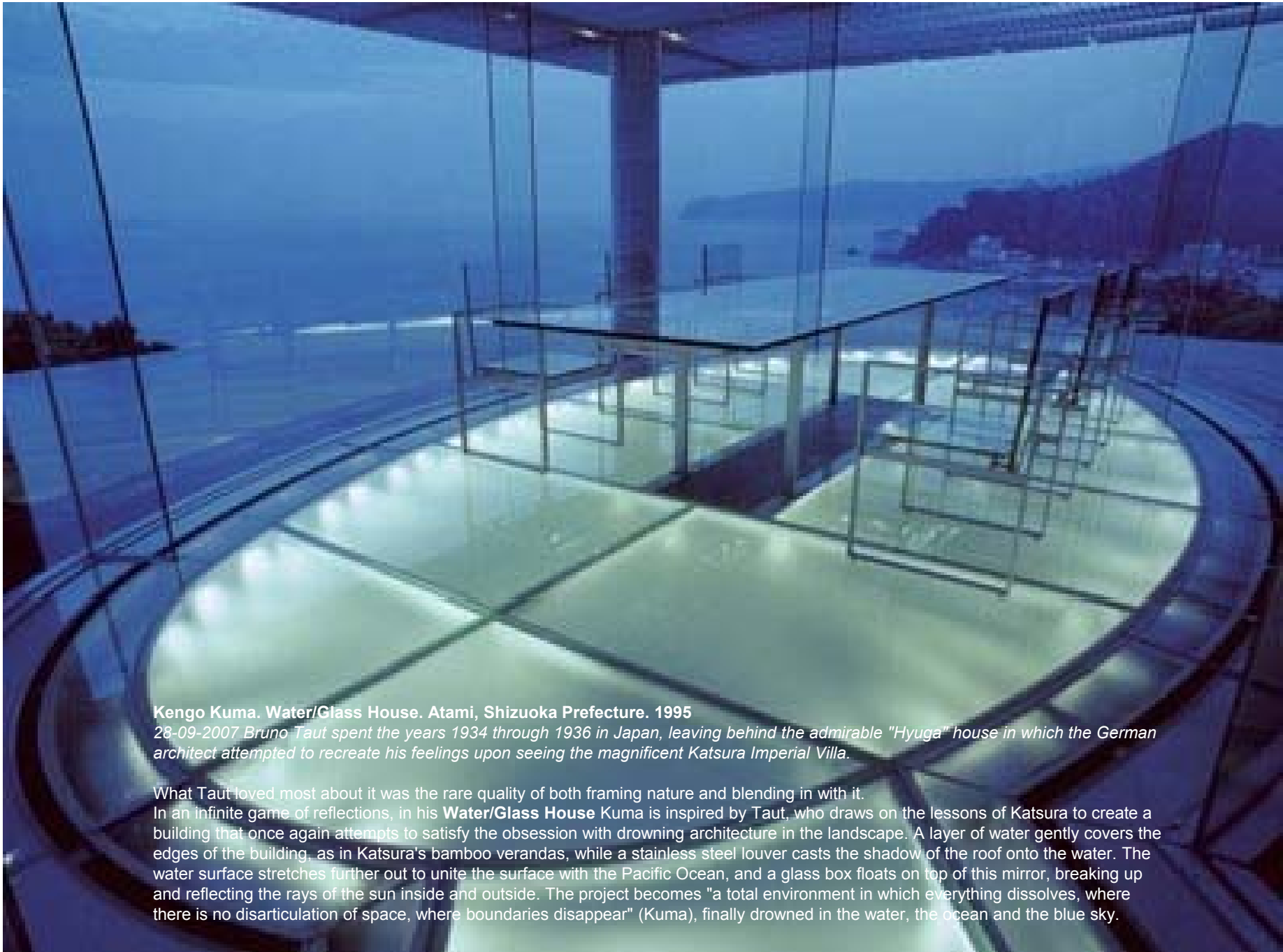

Kengo Kuma. Water/Glass House. Atami, Shizuoka Prefecture. 1995

28-09-2007 Bruno Taut spent the years 1934 through 1936 in Japan, leaving behind the admirable "Hyuga" house in which the German architect attempted to recreate his feelings upon seeing the magnificent Katsura Imperial Villa.

What Taut loved most about it was the rare quality of both framing nature and blending in with it. In an infinite game of reflections, in his **Water/Glass House** Kuma is inspired by Taut, who draws on the lessons of Katsura to create a building that once again attempts to satisfy the obsession with drowning architecture in the landscape. A layer of water gently covers the edges of the building, as in Katsura's bamboo verandas, while a stainless steel louvre casts the shadow of the roof onto the water. The water surface stretches further out to unite the surface with the Pacific Ocean, and a glass box floats on top of this mirror, breaking up and reflecting the rays of the sun inside and outside. The project becomes "a total environment in which everything dissolves, where there is no disarticulation of space, where boundaries disappear" (Kuma), finally drowned in the water, the ocean and the blue sky.

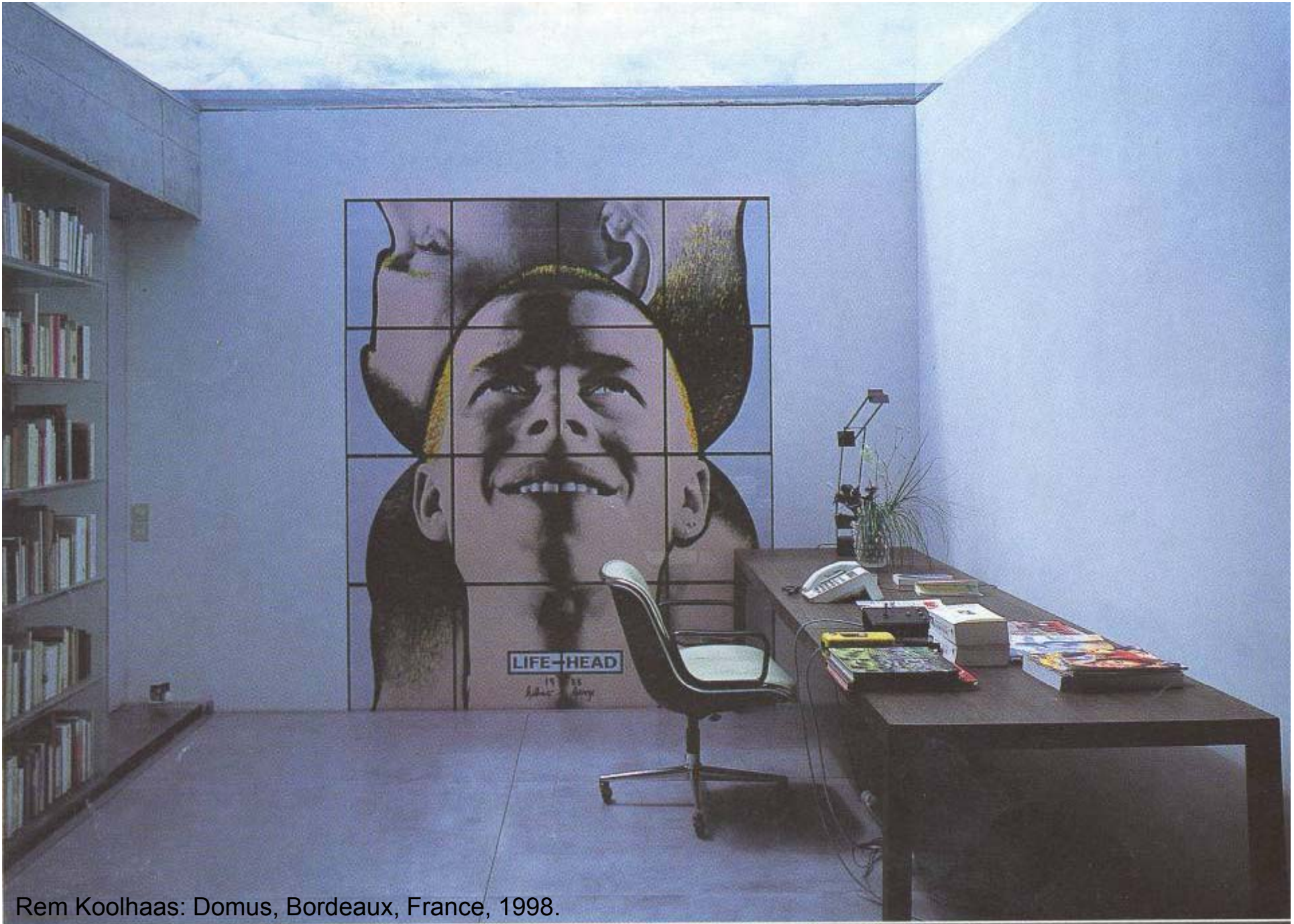

Rem Koolhaas: Domus, Bordeaux, France, 1998.

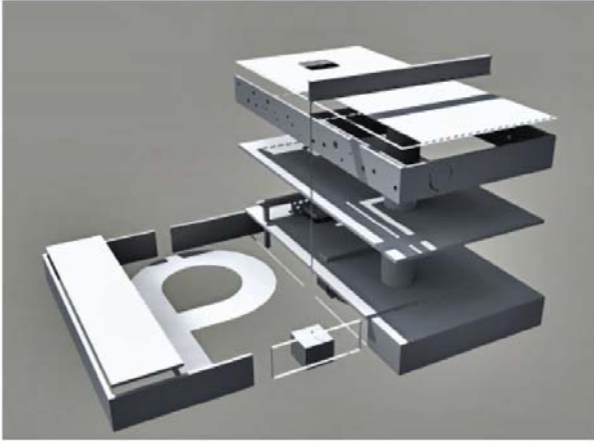
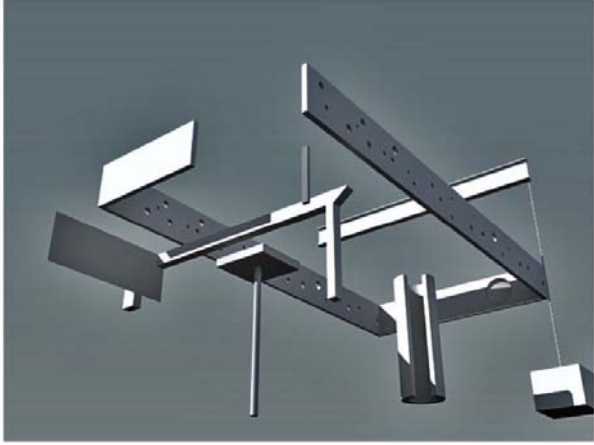
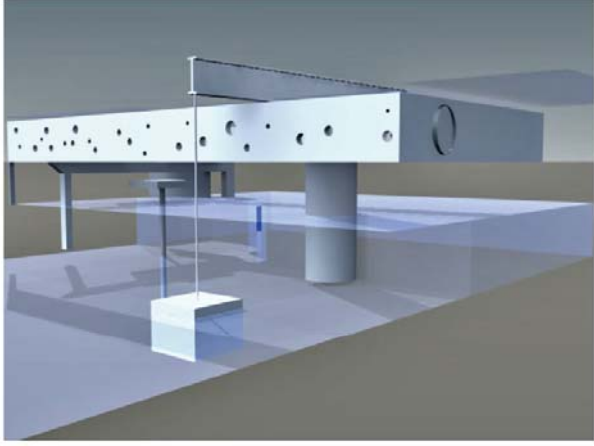

DIGITAL MODEL